

270 Upper Dawson ROAD

SUBMITTED BY

Ray White Rockhampton Casey
stockers@cqoz.com

CREATED ON

2022-09-06

Floors

2

▼ Ground Floor

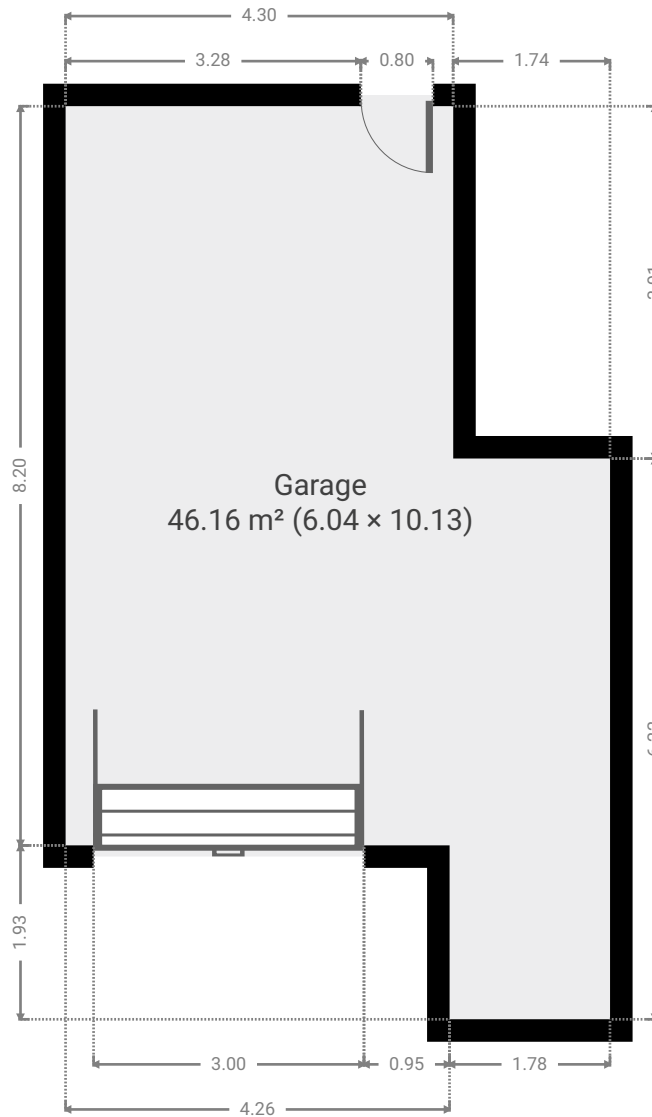

▼ **Garage**
Ground Floor

WIDTH: 6.04 m • LENGTH: 10.13 m
AREA: 46.16 m² • PERIMETER: 32.34 m

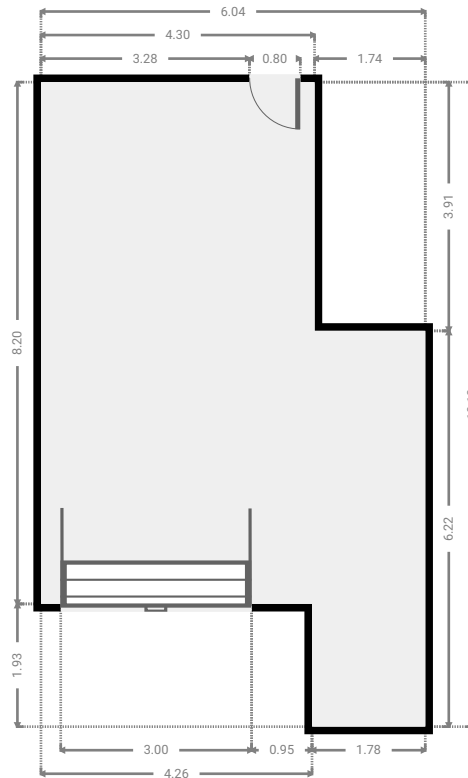
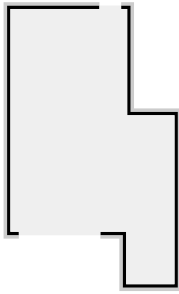

▼ 1st Floor

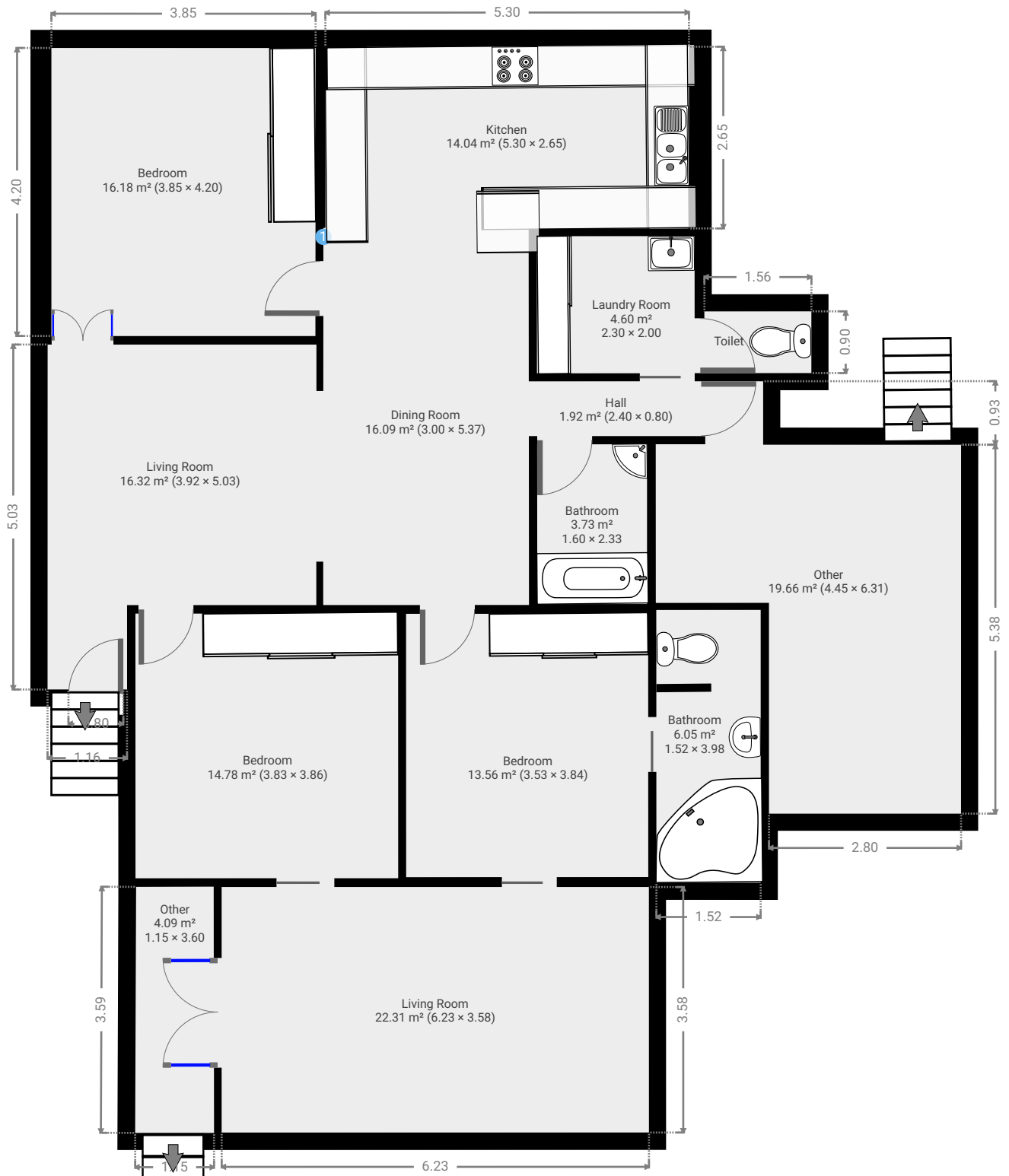

▼ **Bathroom**
1st Floor

WIDTH: 3.98 m • LENGTH: 1.52 m
AREA: 6.05 m² • PERIMETER: 11.00 m

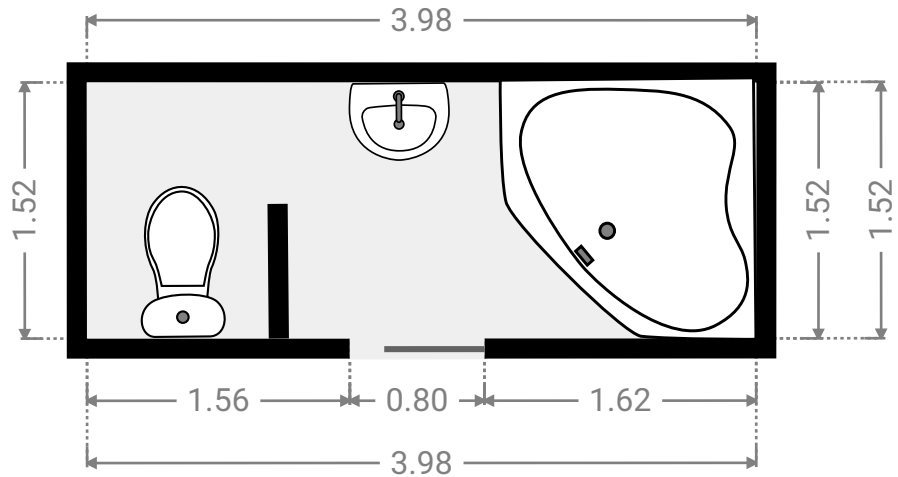
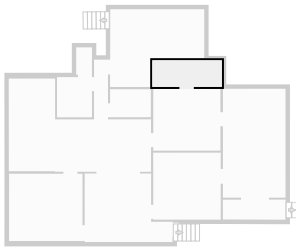

▼ **Bathroom**
1st Floor

WIDTH: 2.33 m • LENGTH: 1.60 m
AREA: 3.73 m² • PERIMETER: 7.86 m

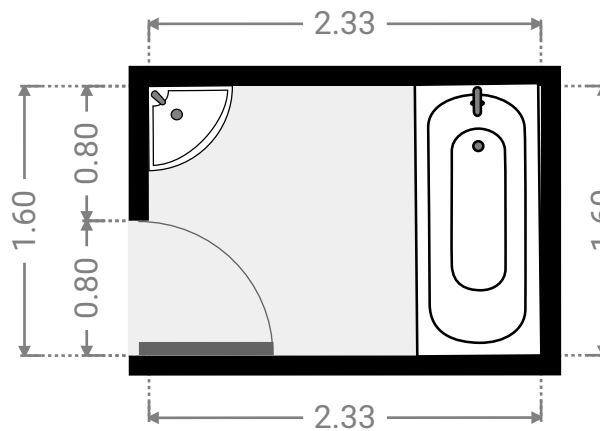
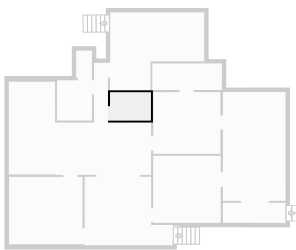

▼ **Bedroom**
1st Floor

WIDTH: 3.86 m • LENGTH: 3.83 m
AREA: 14.78 m² • PERIMETER: 15.38 m

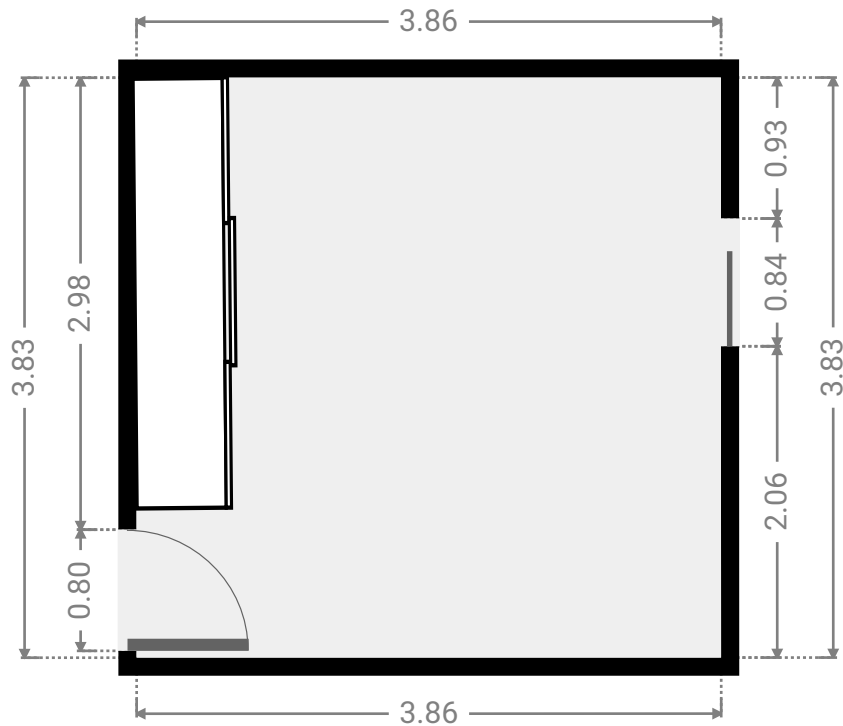
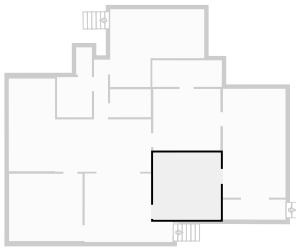

▼ **Bedroom**
1st Floor

WIDTH: 3.84 m • LENGTH: 3.53 m
AREA: 13.56 m² • PERIMETER: 14.74 m

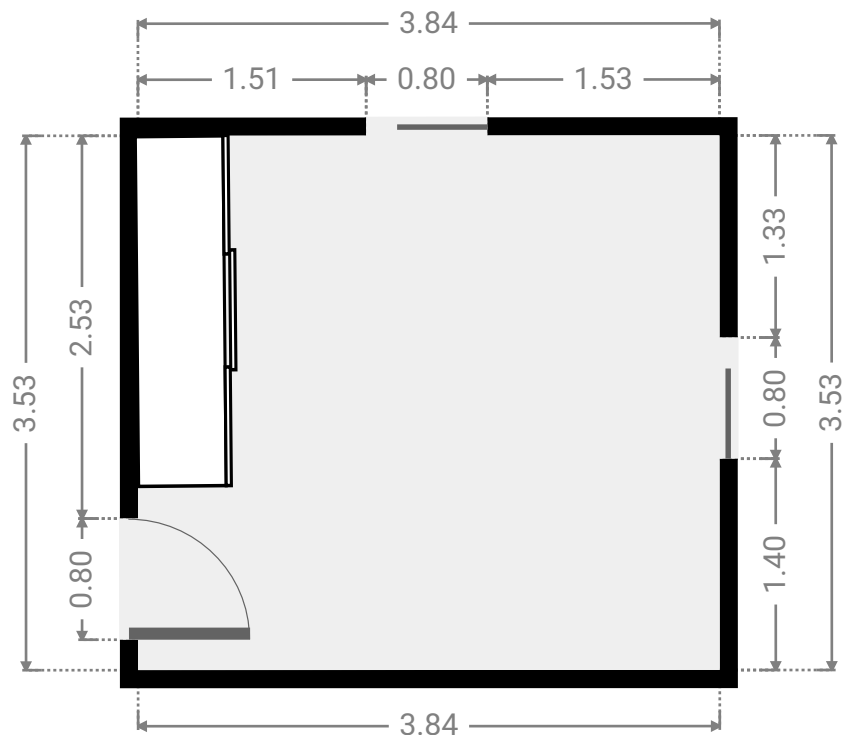
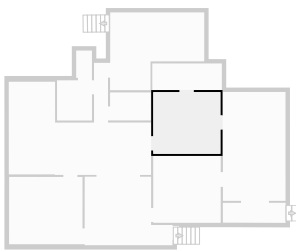

▼ **Bedroom**
1st Floor

WIDTH: 4.20 m • LENGTH: 3.85 m
AREA: 16.18 m² • PERIMETER: 16.10 m

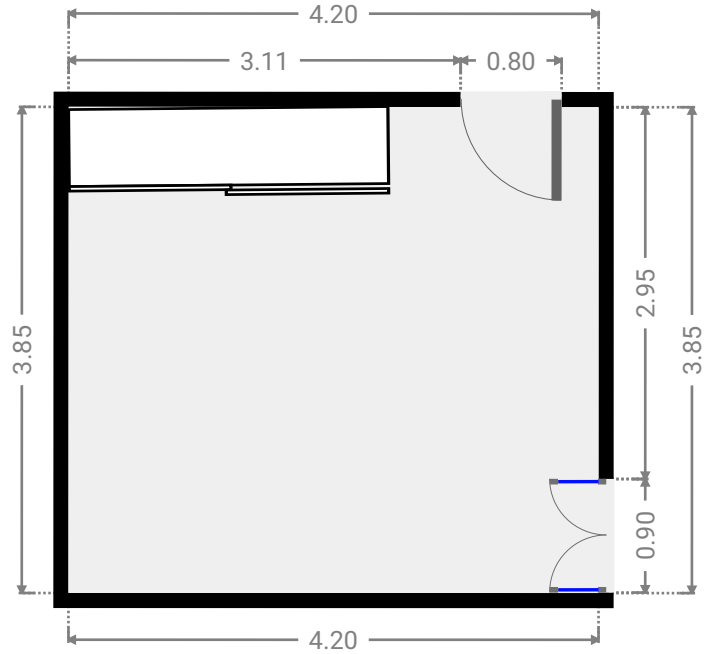
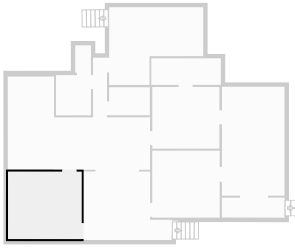

▼ **Dining Room**
1st Floor

WIDTH: 5.37 m • LENGTH: 3.00 m
AREA: 16.09 m² • PERIMETER: 16.73 m

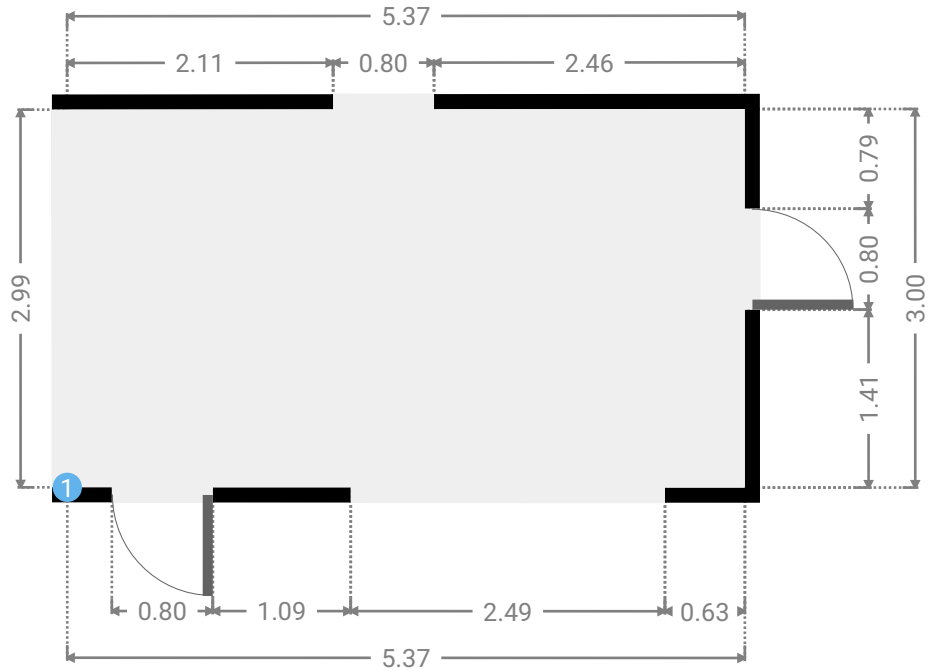
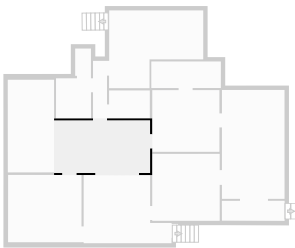

▼ Dining Room/1st Floor

1 OPENING

Height
0.00 m



▼ **Hall**
1st Floor

WIDTH: 0.80 m • LENGTH: 2.40 m
AREA: 1.92 m² • PERIMETER: 6.40 m

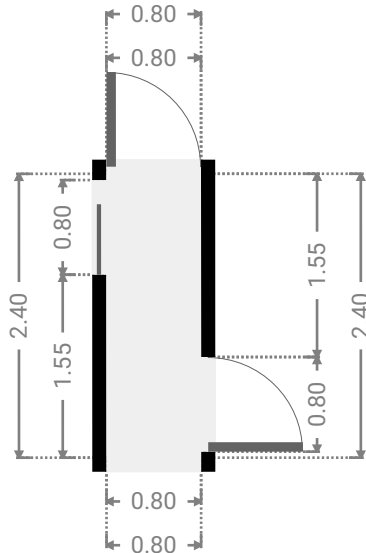
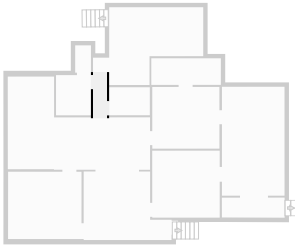

▼ **Kitchen**
1st Floor

WIDTH: 2.65 m • LENGTH: 5.30 m
AREA: 14.04 m² • PERIMETER: 15.90 m

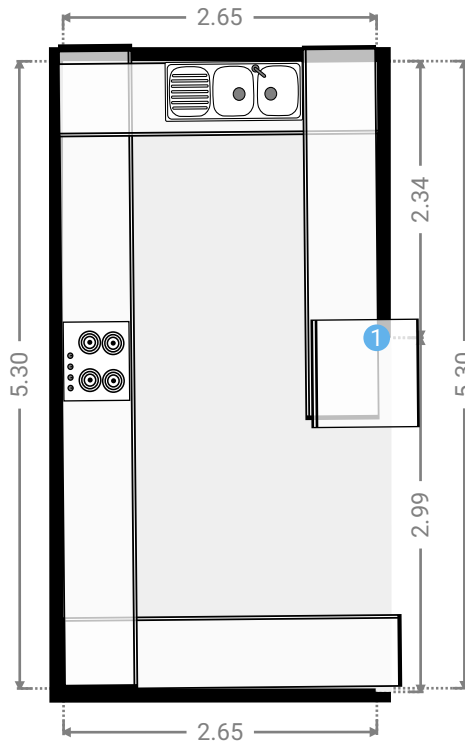
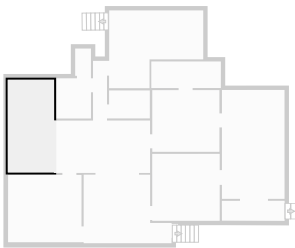

▼ **Laundry Room**
1st Floor

WIDTH: 2.00 m • LENGTH: 2.30 m
AREA: 4.60 m² • PERIMETER: 8.60 m

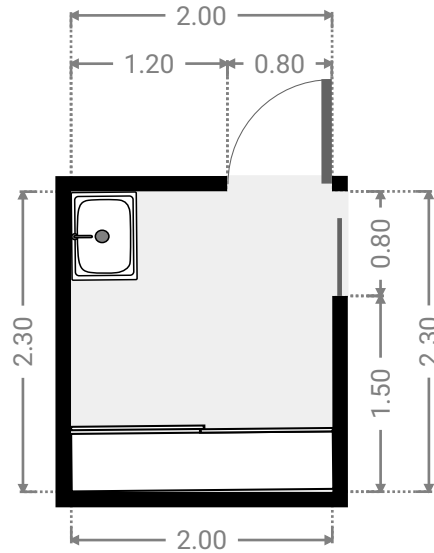
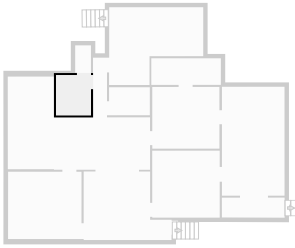

▼ **Living Room**
1st Floor

WIDTH: 5.03 m • LENGTH: 3.92 m
AREA: 16.32 m² • PERIMETER: 17.90 m

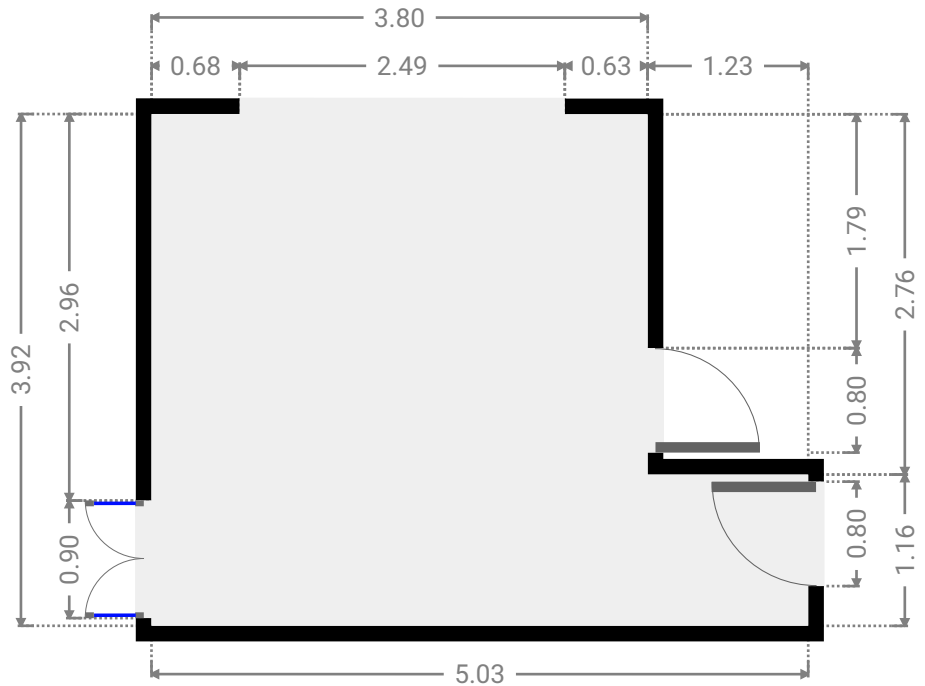
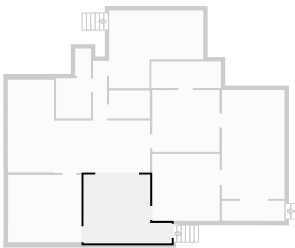

▼ **Living Room**
1st Floor

WIDTH: 3.58 m • LENGTH: 6.23 m
AREA: 22.31 m² • PERIMETER: 19.62 m

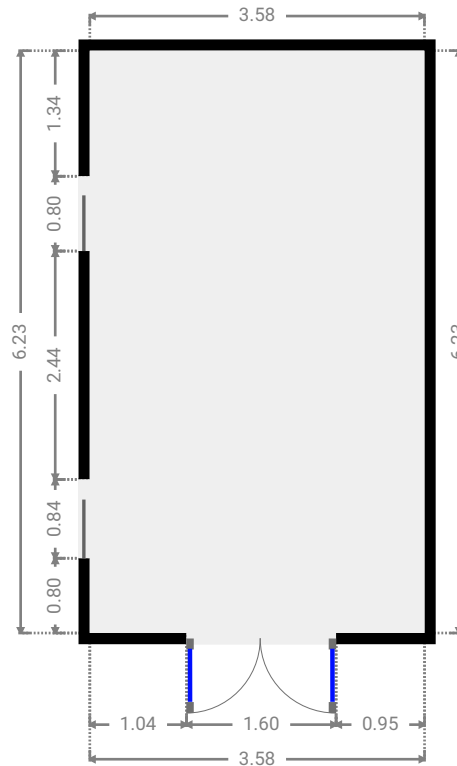
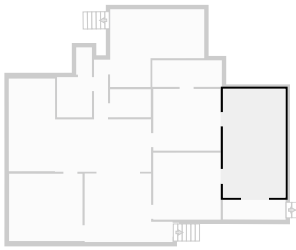

▼ **Other**
1st Floor

WIDTH: 6.31 m • LENGTH: 4.45 m
AREA: 19.66 m² • PERIMETER: 21.51 m

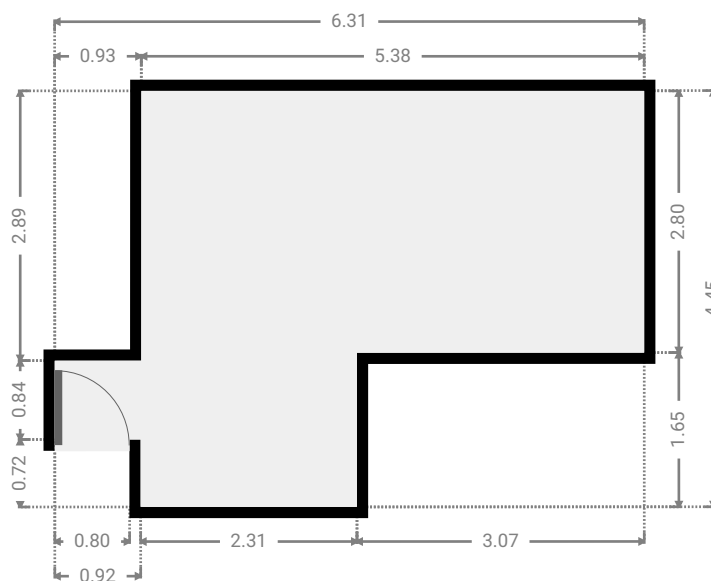
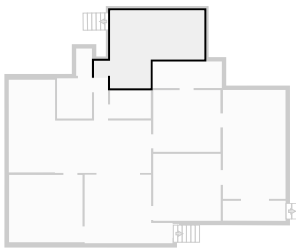

▼ **Other**
1st Floor

WIDTH: 3.60 m • LENGTH: 1.15 m
AREA: 4.09 m² • PERIMETER: 9.46 m

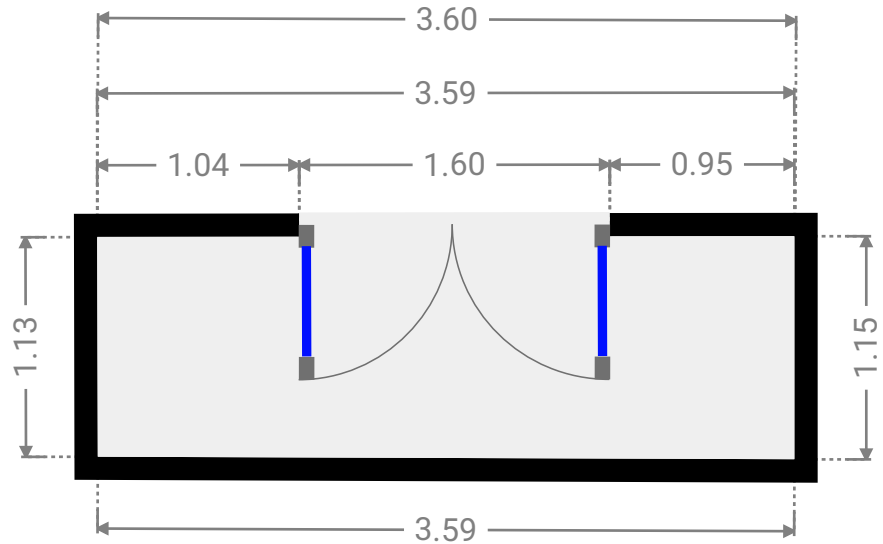
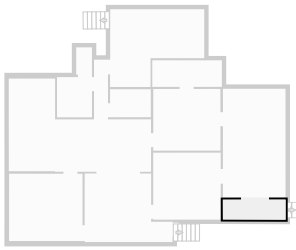

▼ **Toilet**
1st Floor

WIDTH: 0.90 m • LENGTH: 1.56 m
AREA: 1.40 m² • PERIMETER: 4.92 m

