

27 Parnell Street

SUBMITTED BY

Ray White Rockhampton Casey
stockers@cqoz.com

CREATED ON

2021-11-29

Floors

2

▼ Ground Floor

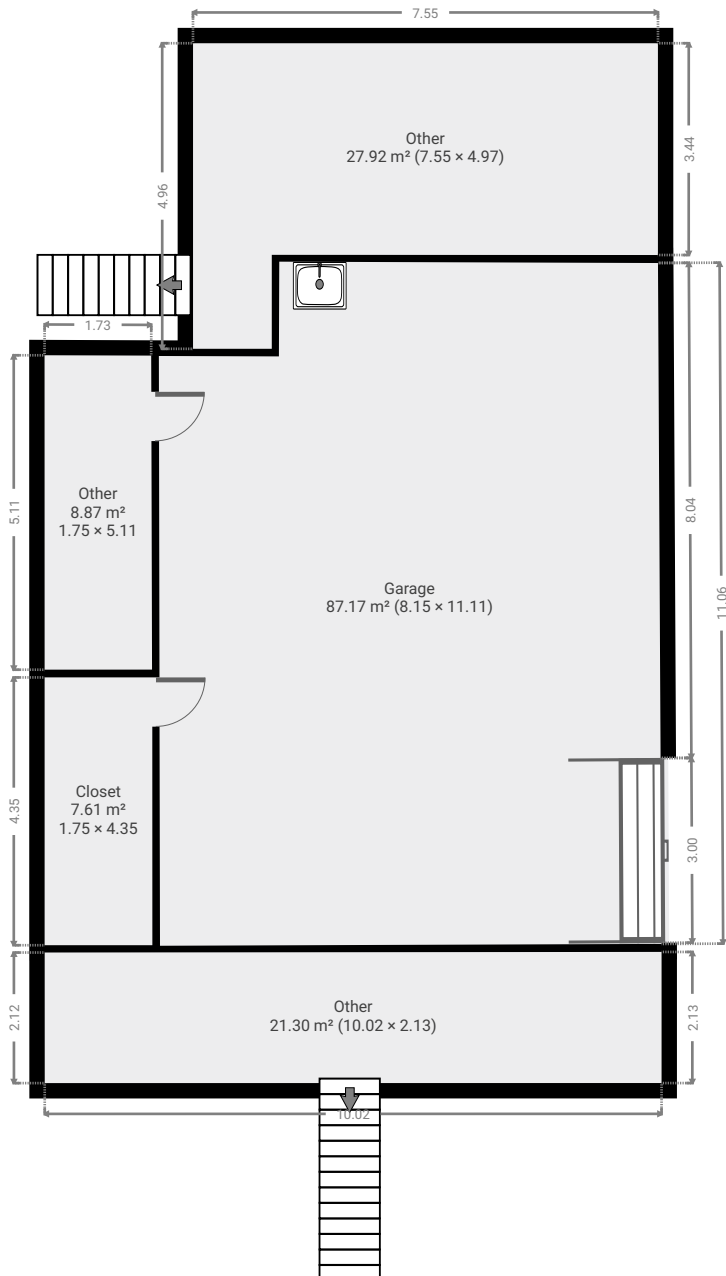

▼ Garage
Ground Floor

WIDTH: 8.15 m • LENGTH: 11.11 m
AREA: 87.17 m² • PERIMETER: 38.44 m

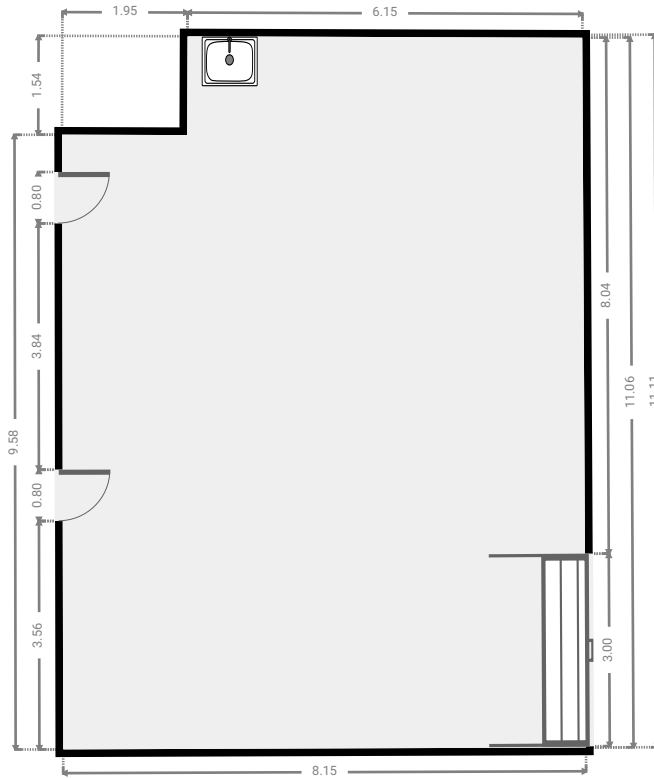
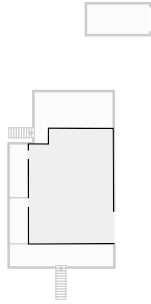

▼ Closet
Ground Floor

WIDTH: 1.75 m • LENGTH: 4.35 m
AREA: 7.61 m² • PERIMETER: 12.20 m

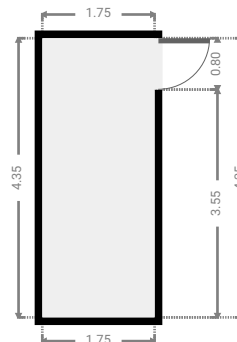
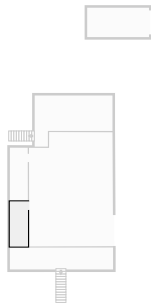

▼ Other
Ground Floor

WIDTH: 1.75 m • LENGTH: 5.11 m
AREA: 8.87 m² • PERIMETER: 13.69 m

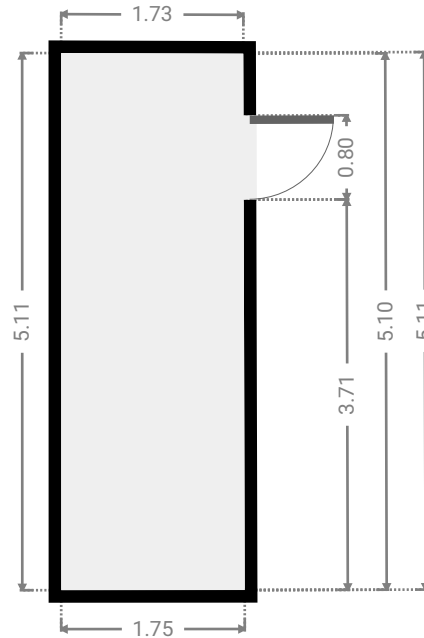
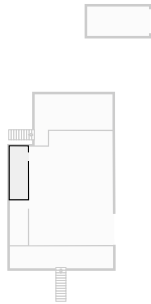

▼ Other
Ground Floor

WIDTH: 7.55 m • LENGTH: 4.97 m
AREA: 27.92 m² • PERIMETER: 25.04 m

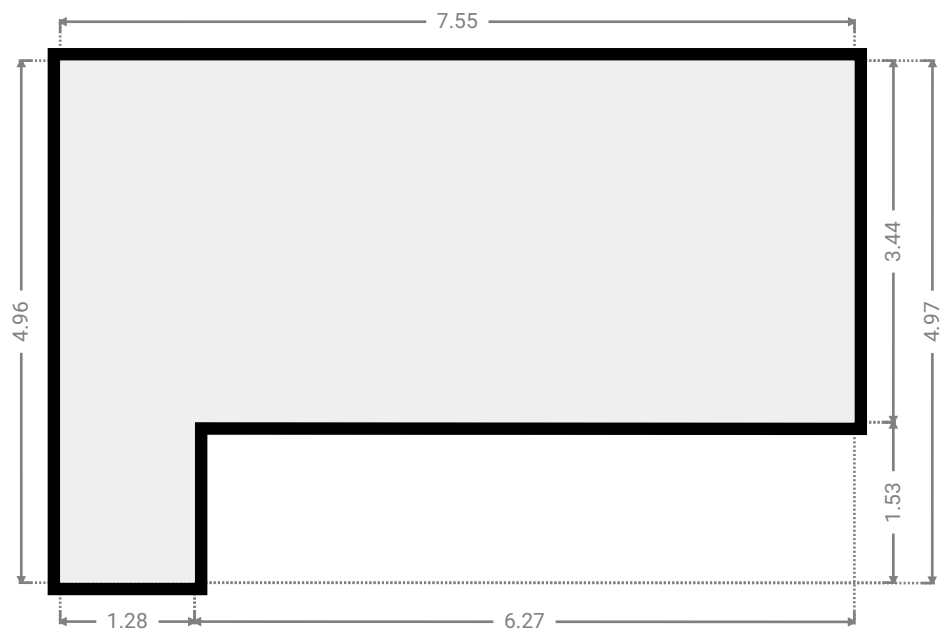
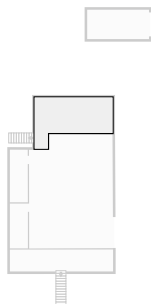

▼ **Garage**
Ground Floor

WIDTH: 6.00 m • LENGTH: 2.85 m
AREA: 17.10 m² • PERIMETER: 17.70 m

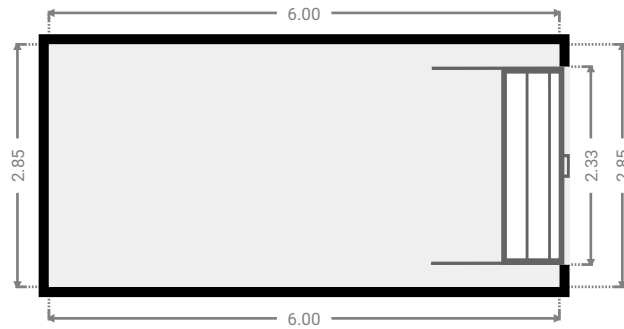
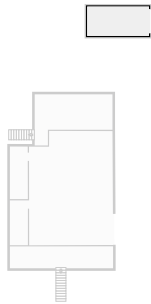

▼ **Other**
Ground Floor

WIDTH: 10.02 m • LENGTH: 2.13 m
AREA: 21.30 m² • PERIMETER: 24.29 m

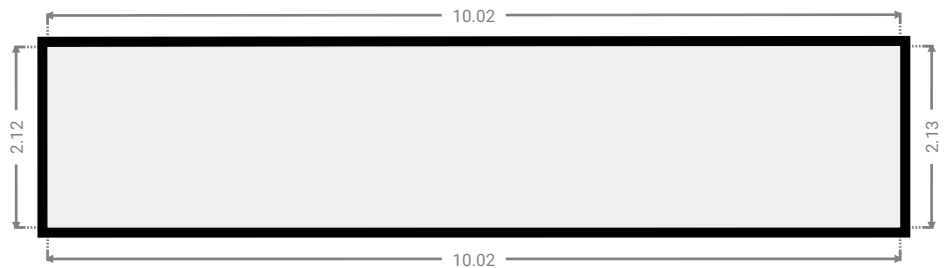
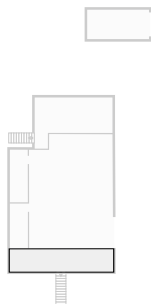

▼ 1st Floor

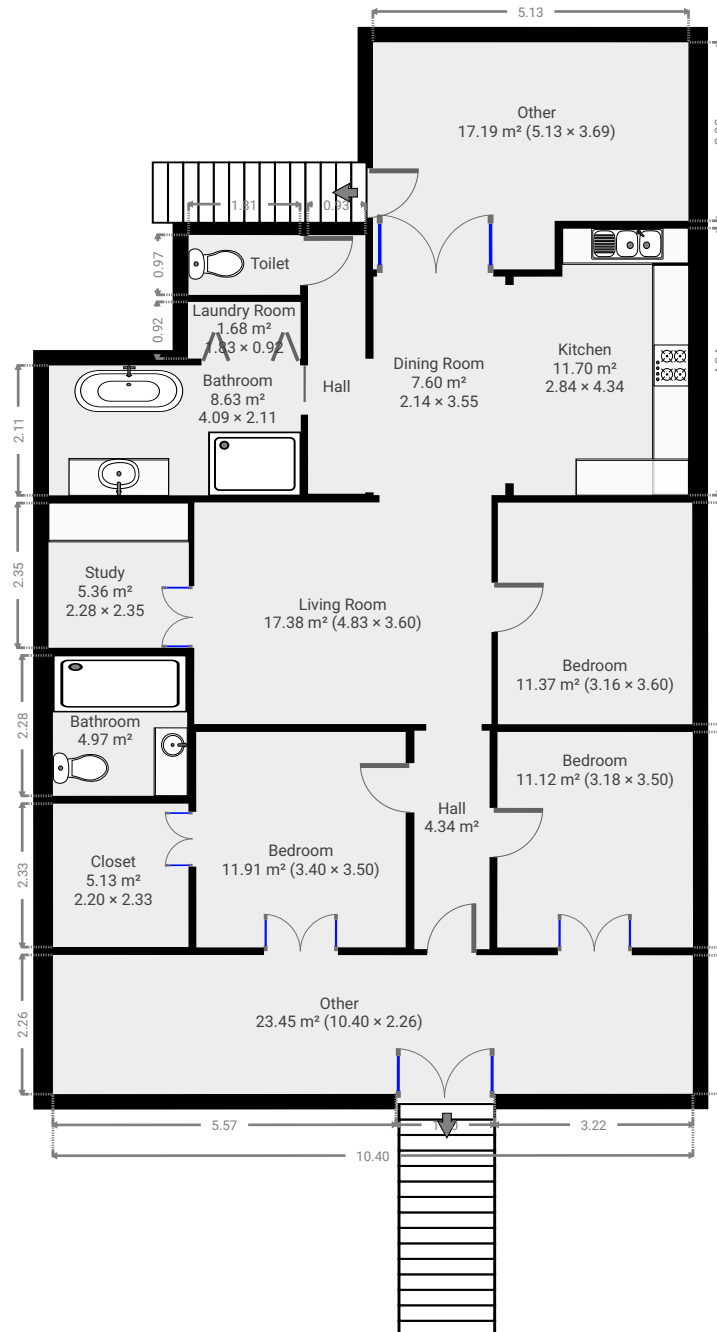

▼ **Hall**
1st Floor

WIDTH: 1.22 m • LENGTH: 3.55 m
AREA: 4.34 m² • PERIMETER: 9.54 m

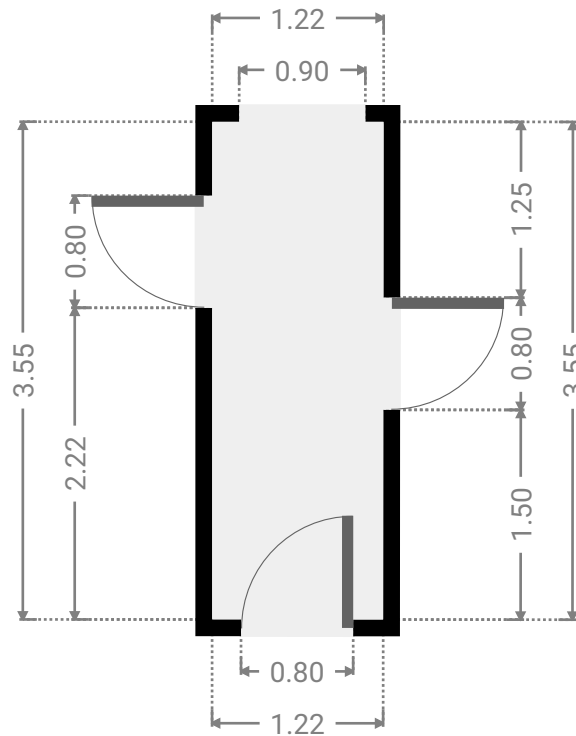
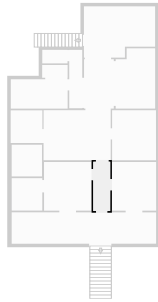

▼ **Bedroom**
1st Floor

WIDTH: 3.18 m • LENGTH: 3.50 m
AREA: 11.12 m² • PERIMETER: 13.36 m

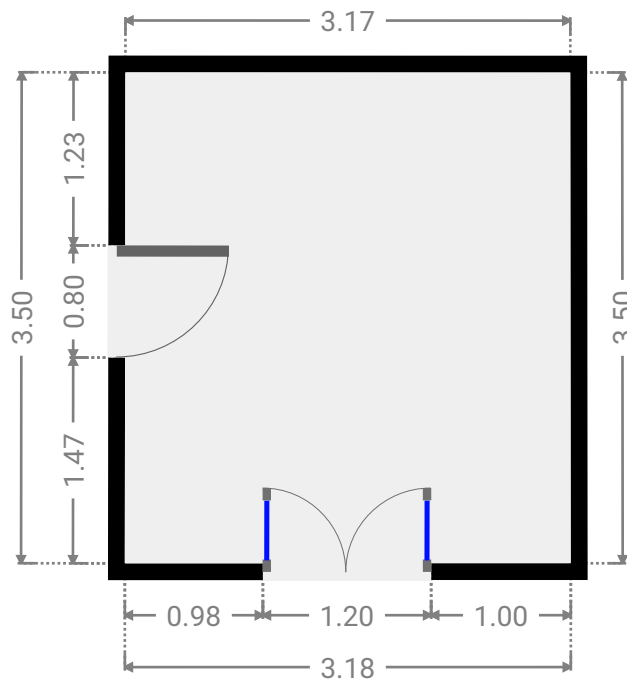
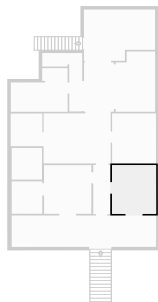

▼ Bedroom
1st Floor

WIDTH: 3.40 m • LENGTH: 3.50 m
AREA: 11.91 m² • PERIMETER: 13.80 m

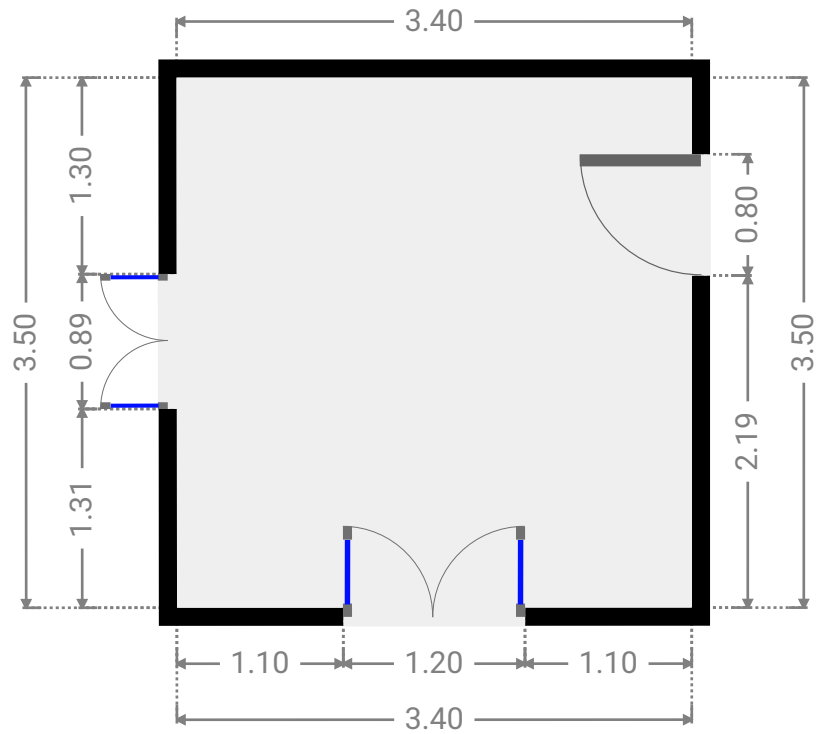
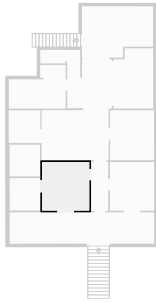

▼ Closet
1st Floor

WIDTH: 2.20 m • LENGTH: 2.33 m
AREA: 5.13 m² • PERIMETER: 9.06 m

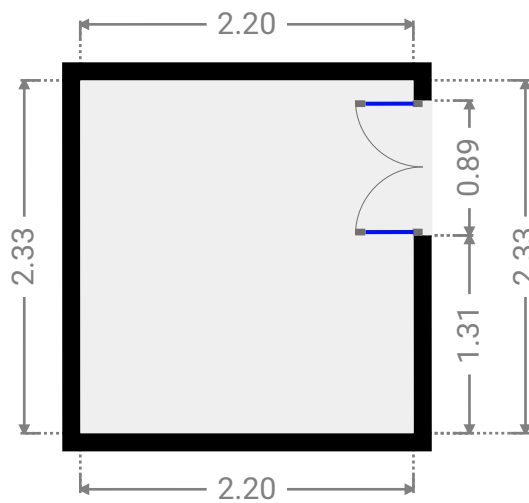
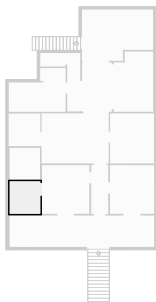

▼ **Bathroom**
1st Floor

WIDTH: 2.18 m • LENGTH: 2.28 m
AREA: 4.97 m² • PERIMETER: 8.92 m

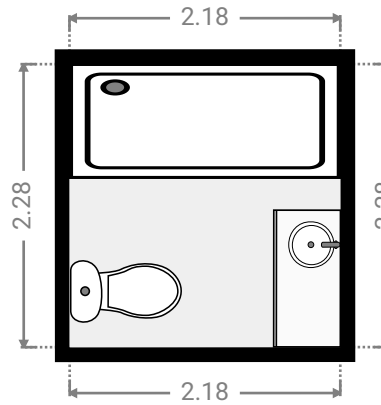
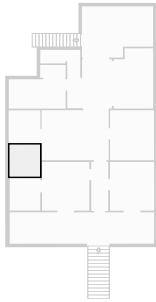

▼ **Living Room**
1st Floor

WIDTH: 4.83 m • LENGTH: 3.60 m
AREA: 17.38 m² • PERIMETER: 16.86 m

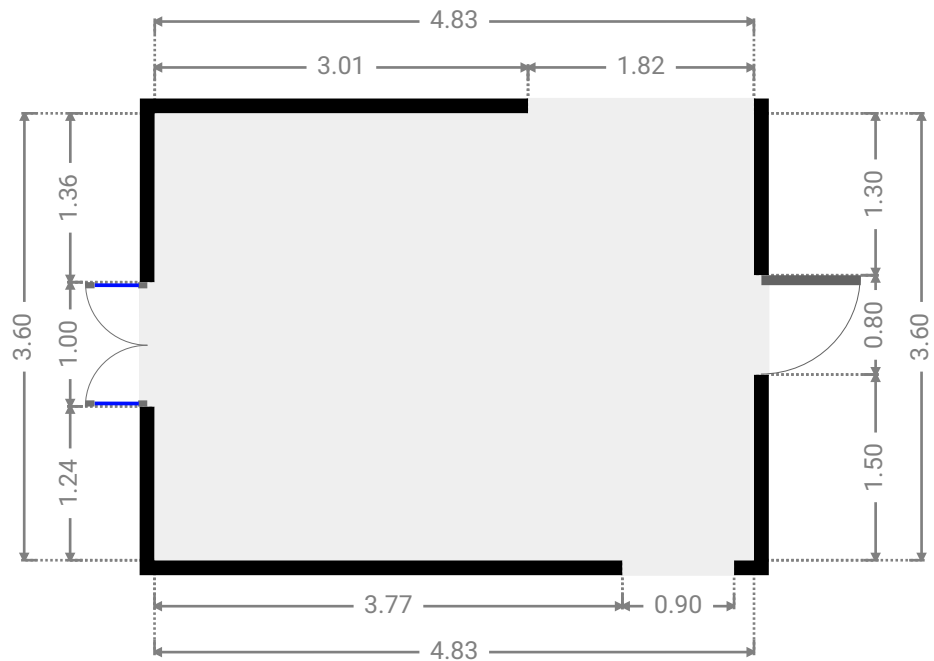
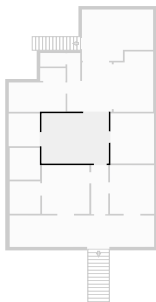

▼ **Study**
1st Floor

WIDTH: 2.28 m • LENGTH: 2.35 m
AREA: 5.36 m² • PERIMETER: 9.26 m

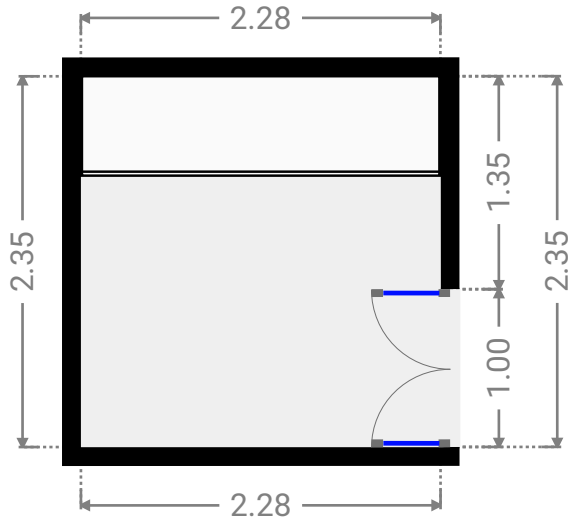
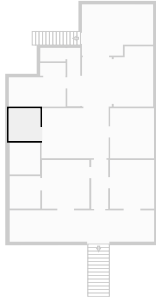

▼ **Bedroom**
1st Floor

WIDTH: 3.16 m • LENGTH: 3.60 m
AREA: 11.37 m² • PERIMETER: 13.52 m

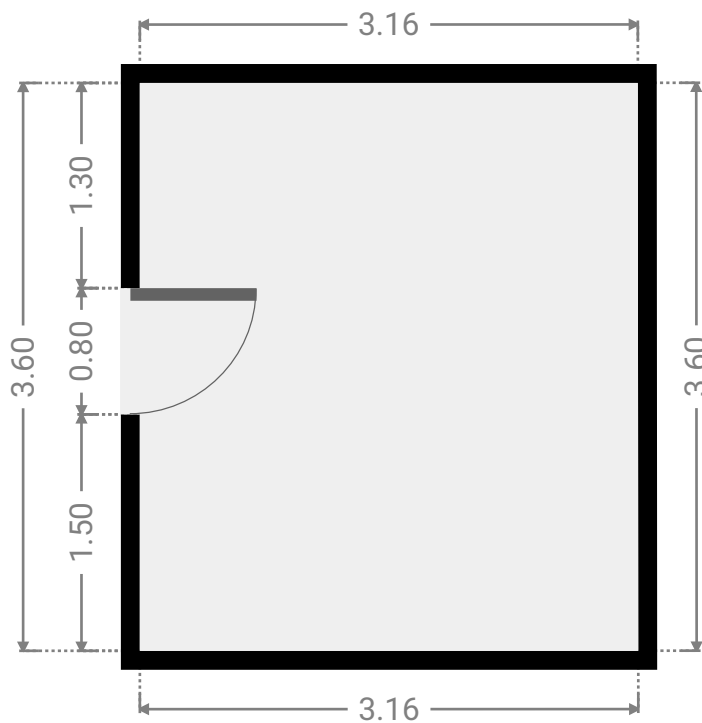
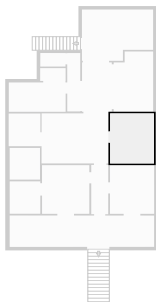

▼ **Dining Room**
1st Floor

WIDTH: 2.14 m • LENGTH: 3.55 m
AREA: 7.60 m² • PERIMETER: 11.38 m

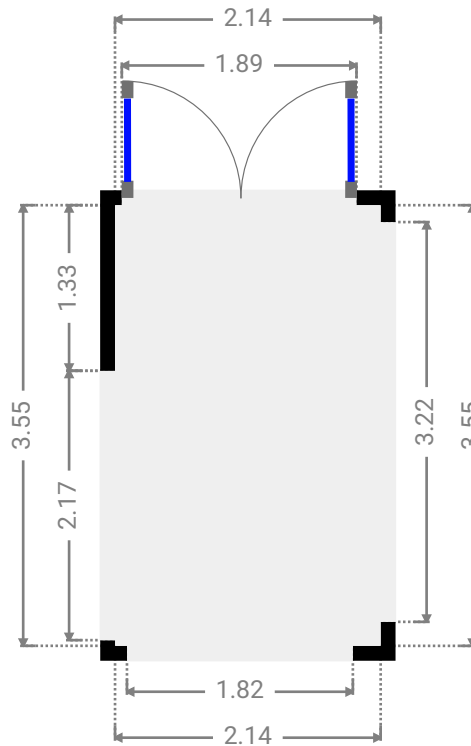
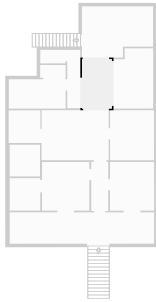

▼ **Kitchen**
1st Floor

WIDTH: 2.84 m • LENGTH: 4.34 m
AREA: 11.70 m² • PERIMETER: 14.35 m

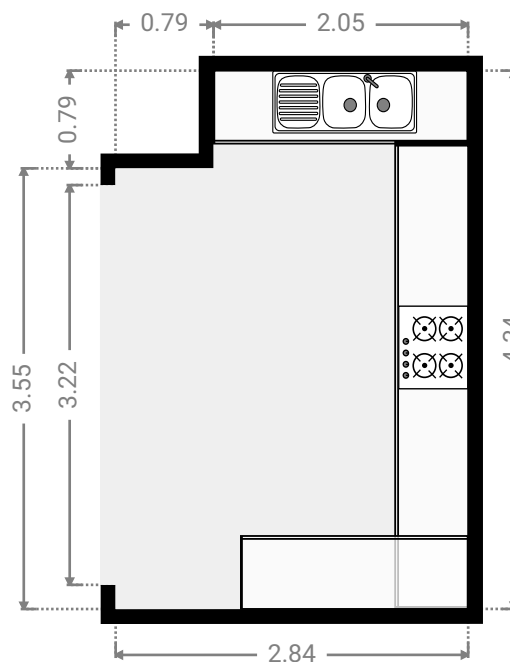
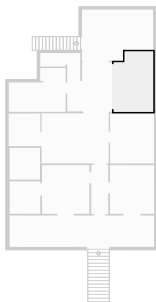

▼ **Hall**
1st Floor

WIDTH: 0.93 m • LENGTH: 4.20 m
AREA: 3.91 m² • PERIMETER: 10.26 m

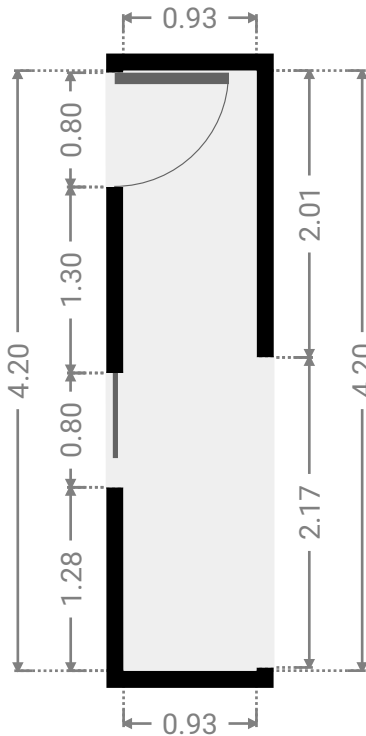
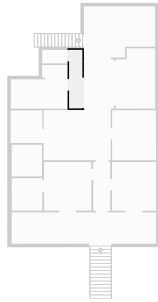

▼ **Bathroom**
1st Floor

WIDTH: 4.09 m • LENGTH: 2.11 m
AREA: 8.63 m² • PERIMETER: 12.40 m

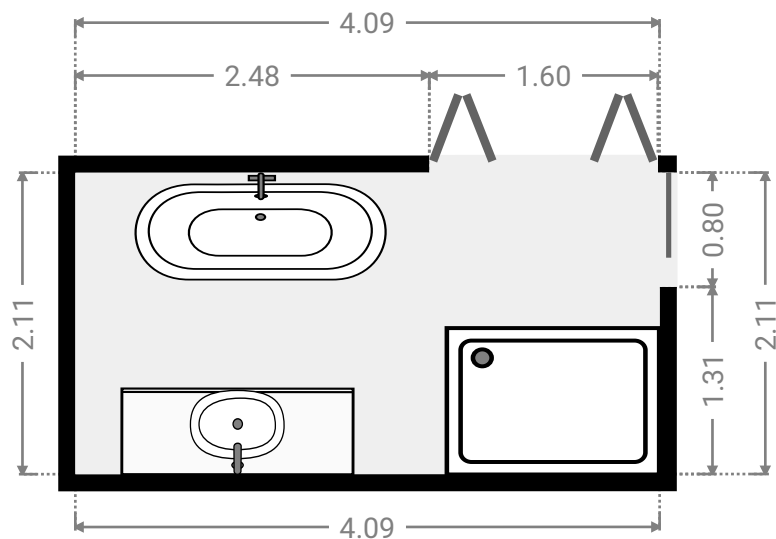
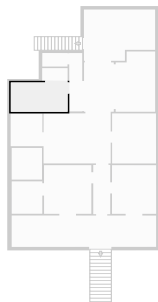

▼ **Laundry Room**
1st Floor

WIDTH: 1.83 m • LENGTH: 0.92 m
AREA: 1.68 m² • PERIMETER: 5.50 m

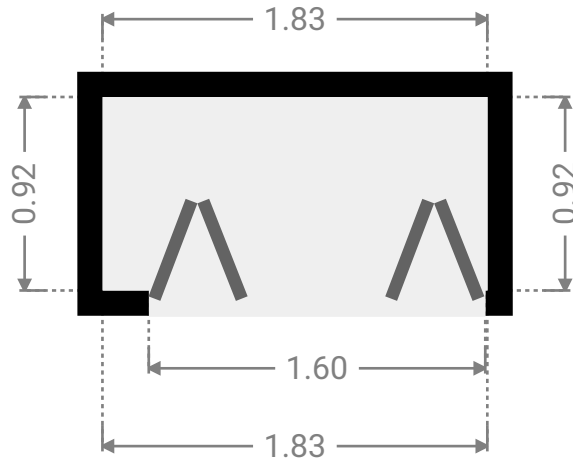
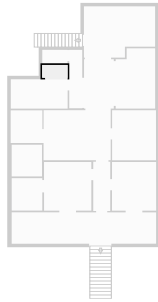

▼ **Toilet**
1st Floor

WIDTH: 1.81 m • LENGTH: 0.98 m
AREA: 1.76 m² • PERIMETER: 5.57 m

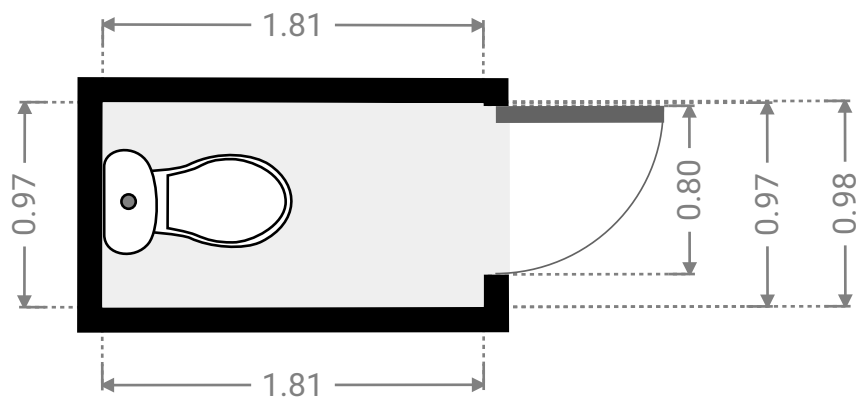
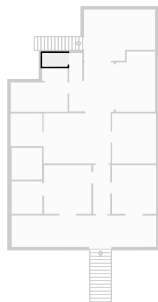

▼ Other
1st Floor

WIDTH: 5.13 m • LENGTH: 3.69 m
AREA: 17.19 m² • PERIMETER: 17.63 m

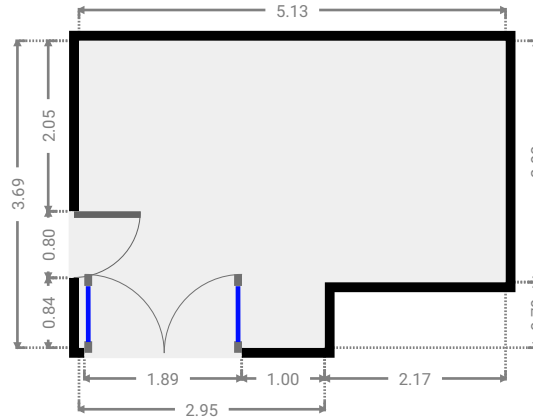
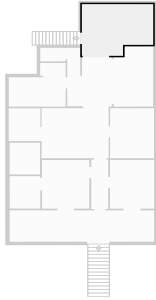

▼ Other
1st Floor

WIDTH: 10.40 m • LENGTH: 2.26 m
AREA: 23.45 m² • PERIMETER: 25.30 m

