

269 Rockonia Road

SUBMITTED BY

Ray White Rockhampton Casey
stockers@cqoz.com

CREATED ON

2022-12-01

Floors

1

▼ Ground Floor

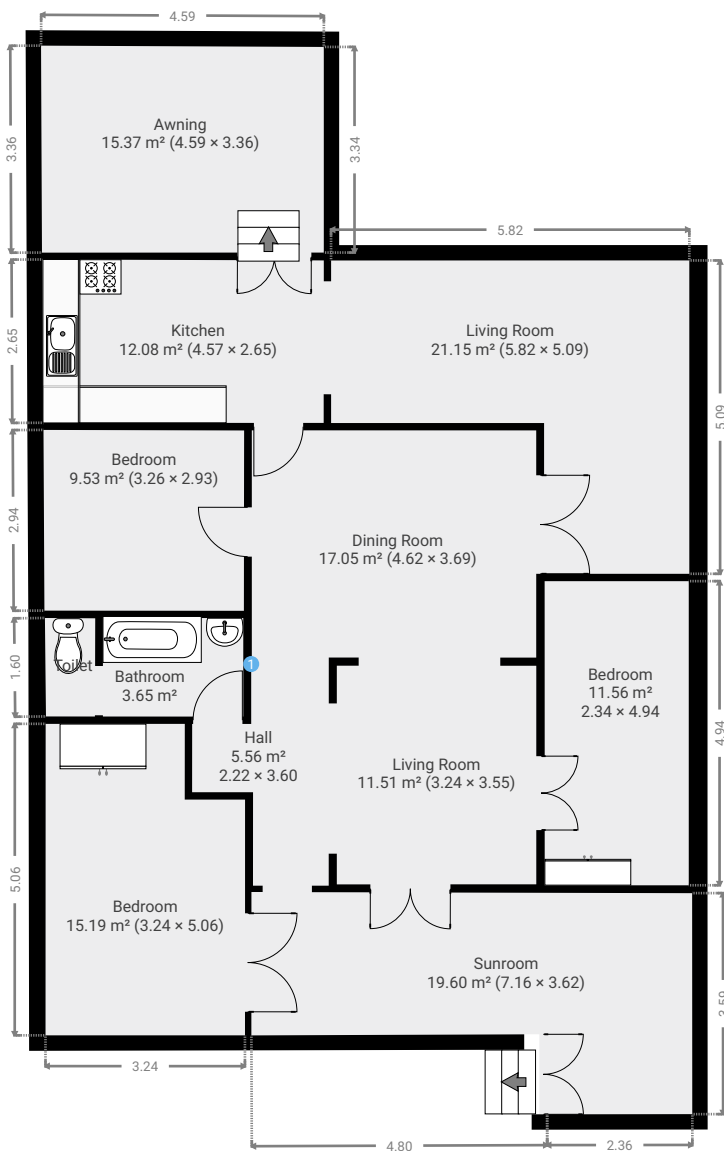
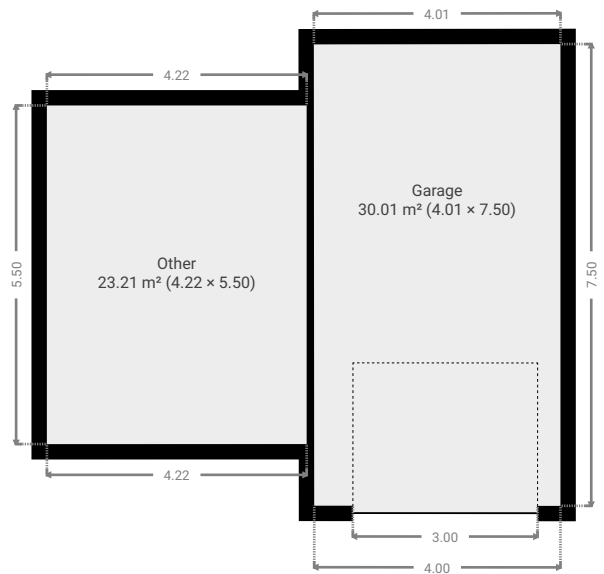

FLOORS: 1

▼ **Awning**
Ground Floor

WIDTH: 4.59 m • LENGTH: 3.36 m
AREA: 15.37 m² • PERIMETER: 15.87 m

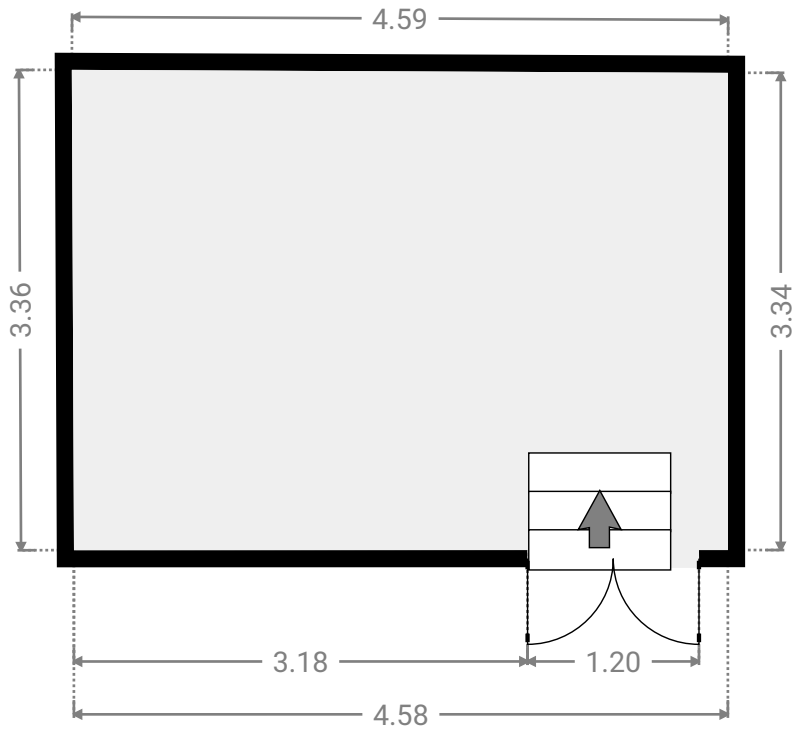
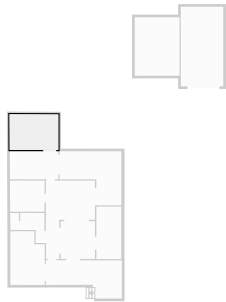

▼ **Bathroom**
Ground Floor

WIDTH: 2.28 m • LENGTH: 1.60 m
AREA: 3.65 m² • PERIMETER: 7.76 m

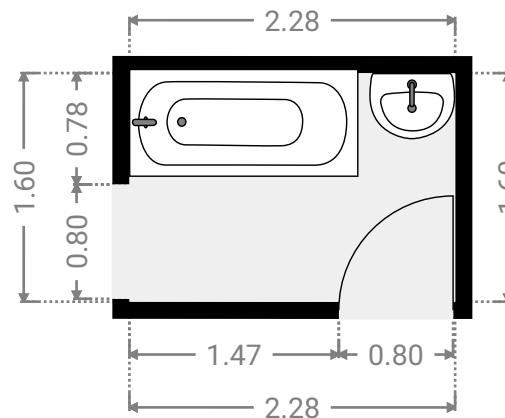
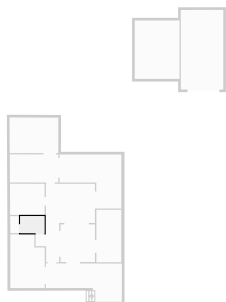

FLOORS: 1

▼ **Bedroom**
Ground Floor

WIDTH: 3.24 m • LENGTH: 5.06 m
AREA: 15.19 m² • PERIMETER: 16.60 m

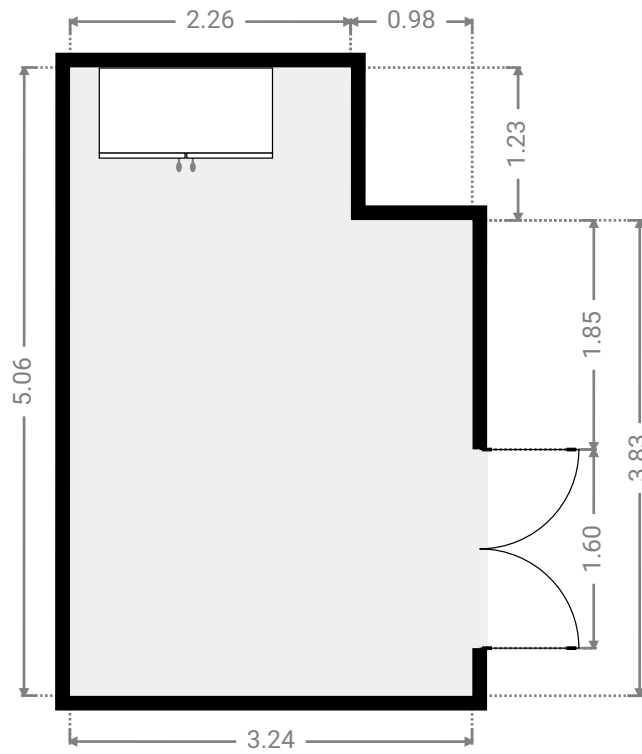

▼ **Bedroom**
Ground Floor

WIDTH: 2.34 m • LENGTH: 4.94 m
AREA: 11.56 m² • PERIMETER: 14.56 m

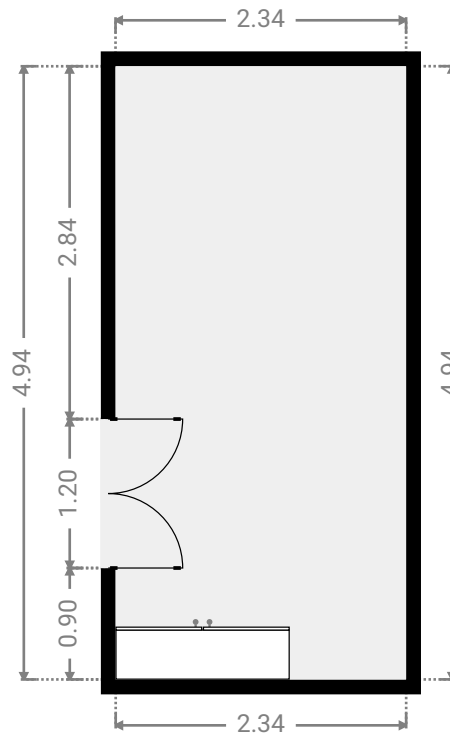
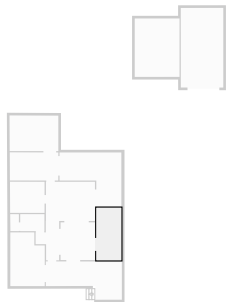

FLOORS: 1

▼ **Bedroom**
Ground Floor

WIDTH: 3.26 m • LENGTH: 2.93 m
AREA: 9.53 m² • PERIMETER: 12.36 m

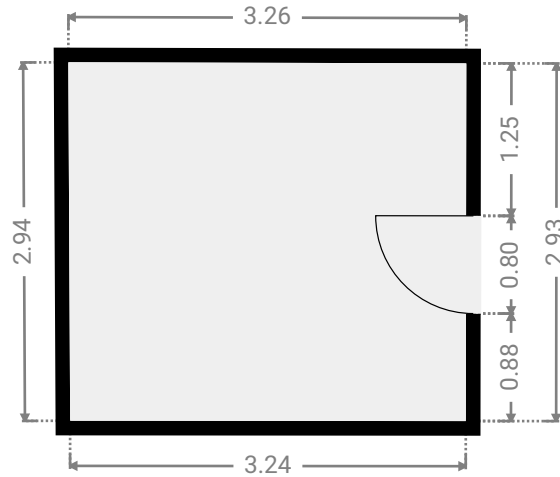
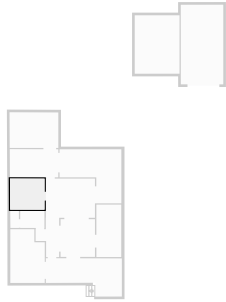

▼ **Dining Room**
Ground Floor

WIDTH: 4.62 m • LENGTH: 3.69 m
AREA: 17.05 m² • PERIMETER: 16.62 m

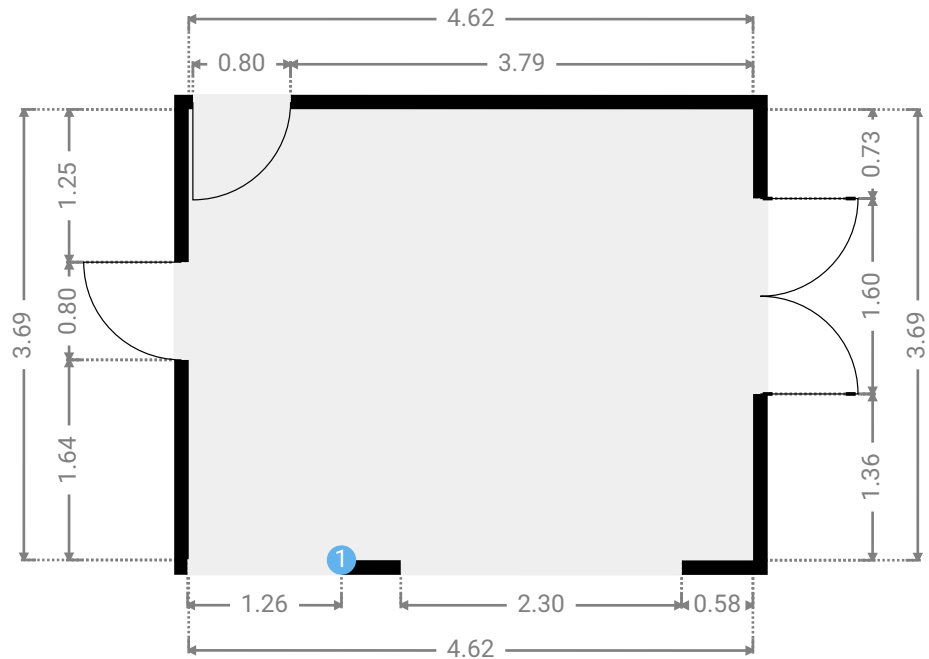
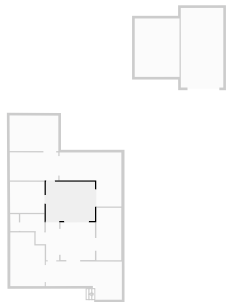

FLOORS: 1

▼ **Garage**
Ground Floor

WIDTH: 4.01 m • LENGTH: 7.50 m
AREA: 30.01 m² • PERIMETER: 23.00 m

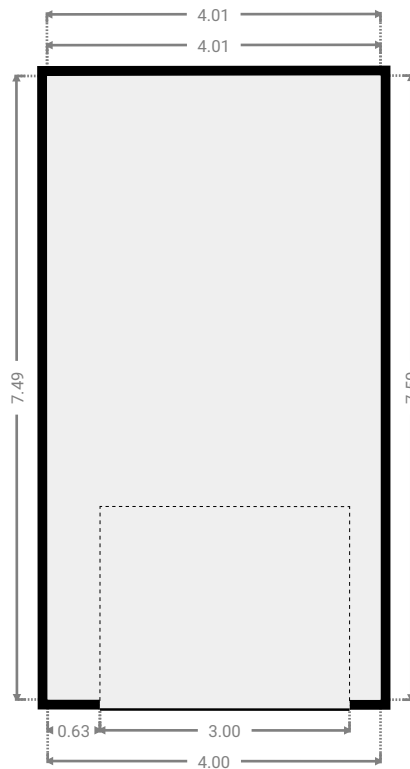
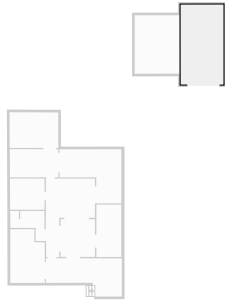

▼ **Hall**
Ground Floor

WIDTH: 2.22 m • LENGTH: 3.60 m
AREA: 5.56 m² • PERIMETER: 11.64 m

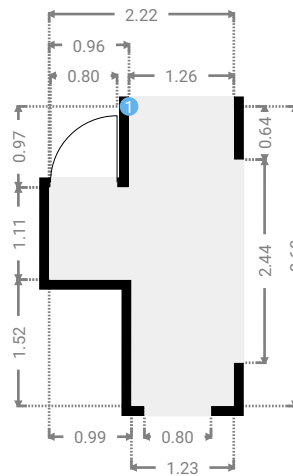

▼ **Hall/**Ground Floor

1 OPENING

Height
0.00 m



FLOORS: 1

▼ Kitchen
Ground Floor

WIDTH: 4.57 m • LENGTH: 2.65 m
AREA: 12.08 m² • PERIMETER: 14.42 m

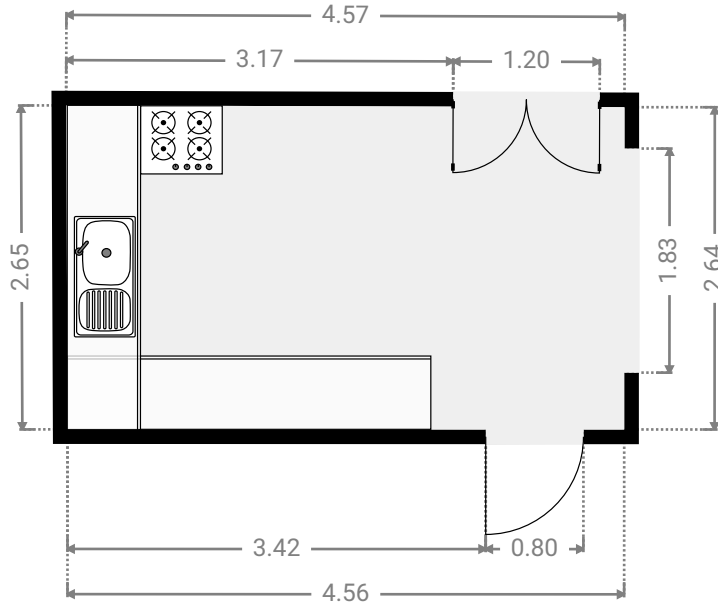
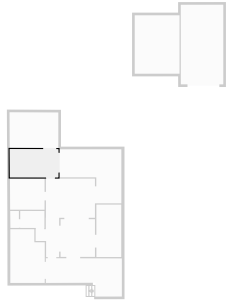

▼ Living Room
Ground Floor

WIDTH: 3.24 m • LENGTH: 3.55 m
AREA: 11.51 m² • PERIMETER: 13.58 m

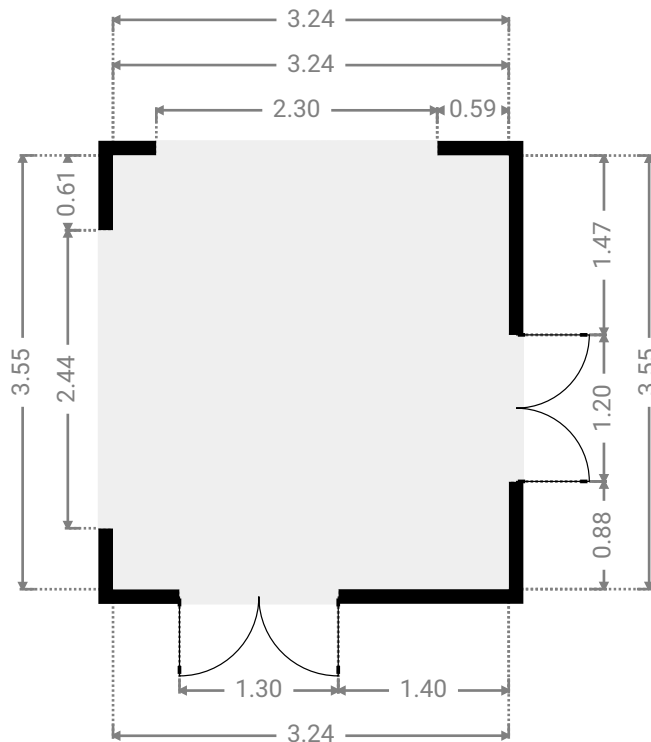
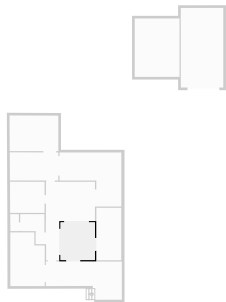

FLOORS: 1

▼ **Living Room**
Ground Floor

WIDTH: 5.82 m • LENGTH: 5.09 m
AREA: 21.15 m² • PERIMETER: 21.82 m

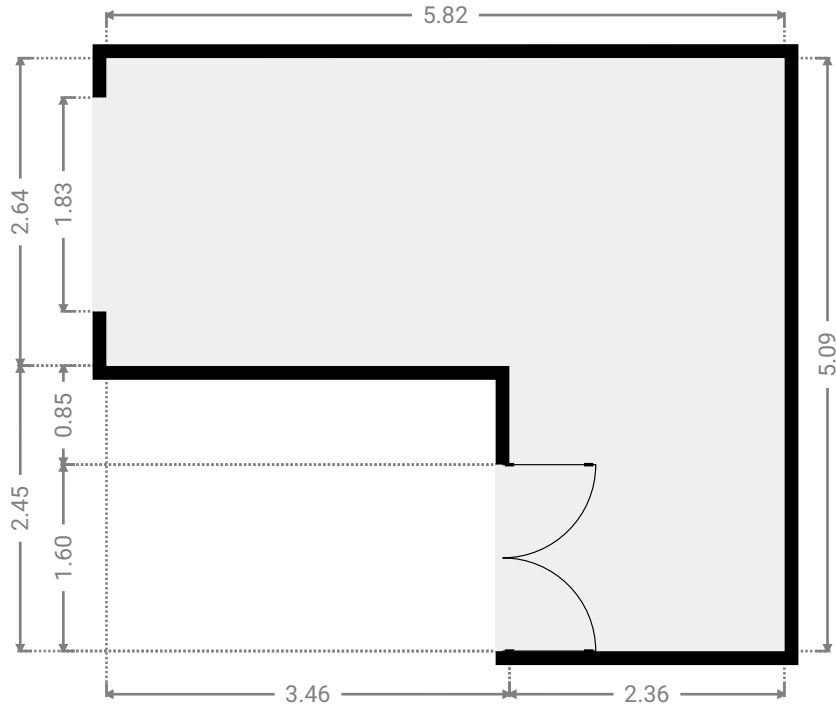
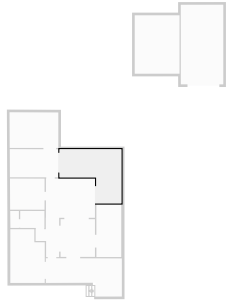

▼ **Other**
Ground Floor

WIDTH: 4.22 m • LENGTH: 5.50 m
AREA: 23.21 m² • PERIMETER: 19.44 m

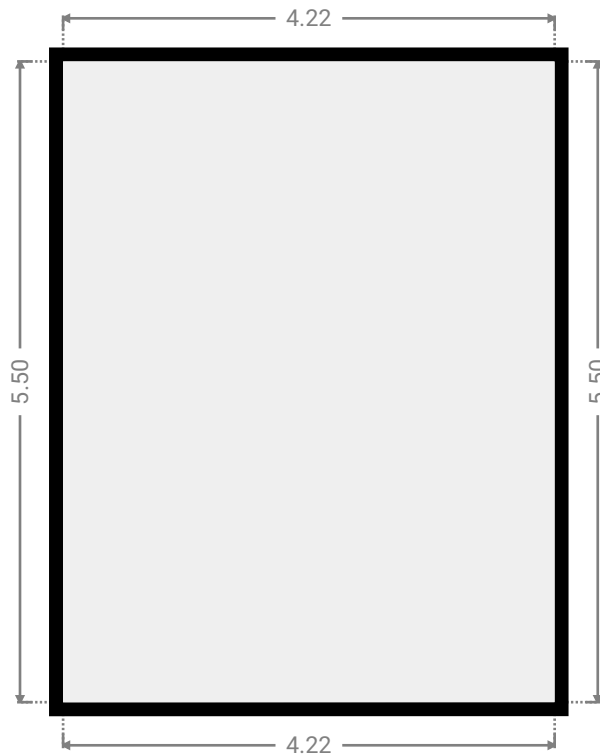
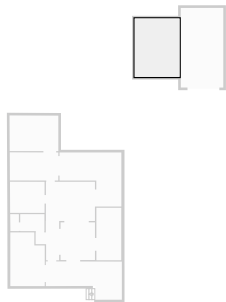

FLOORS: 1

▼ **Sunroom**
Ground Floor

WIDTH: 7.16 m • LENGTH: 3.62 m
AREA: 19.60 m² • PERIMETER: 21.54 m

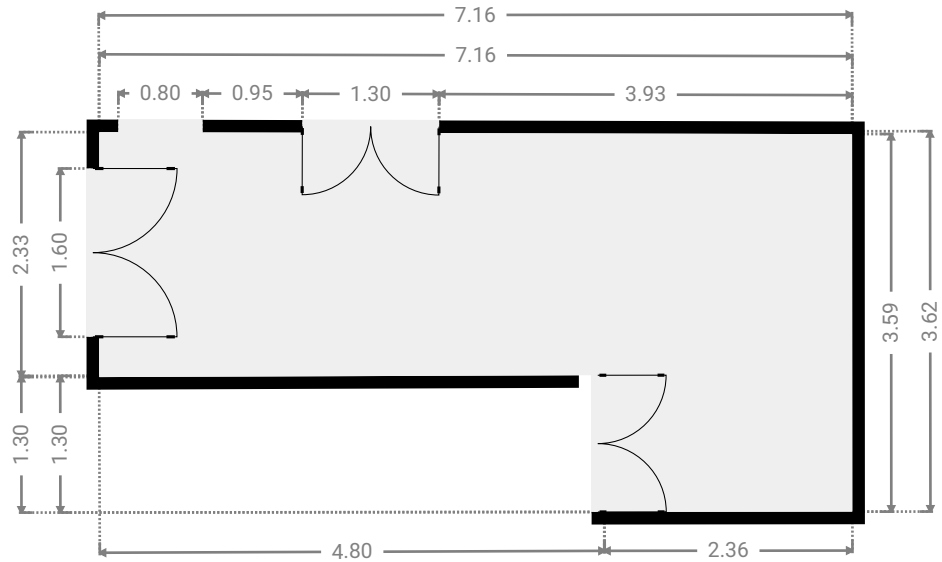
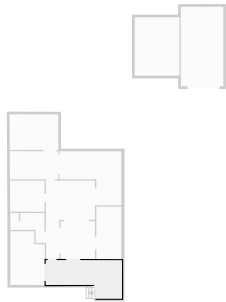

▼ **Toilet**
Ground Floor

WIDTH: 0.82 m • LENGTH: 1.60 m
AREA: 1.29 m² • PERIMETER: 4.81 m

