

265 Ford Street

Created on
2017-06-01

Floors
2

▼ Ground Floor

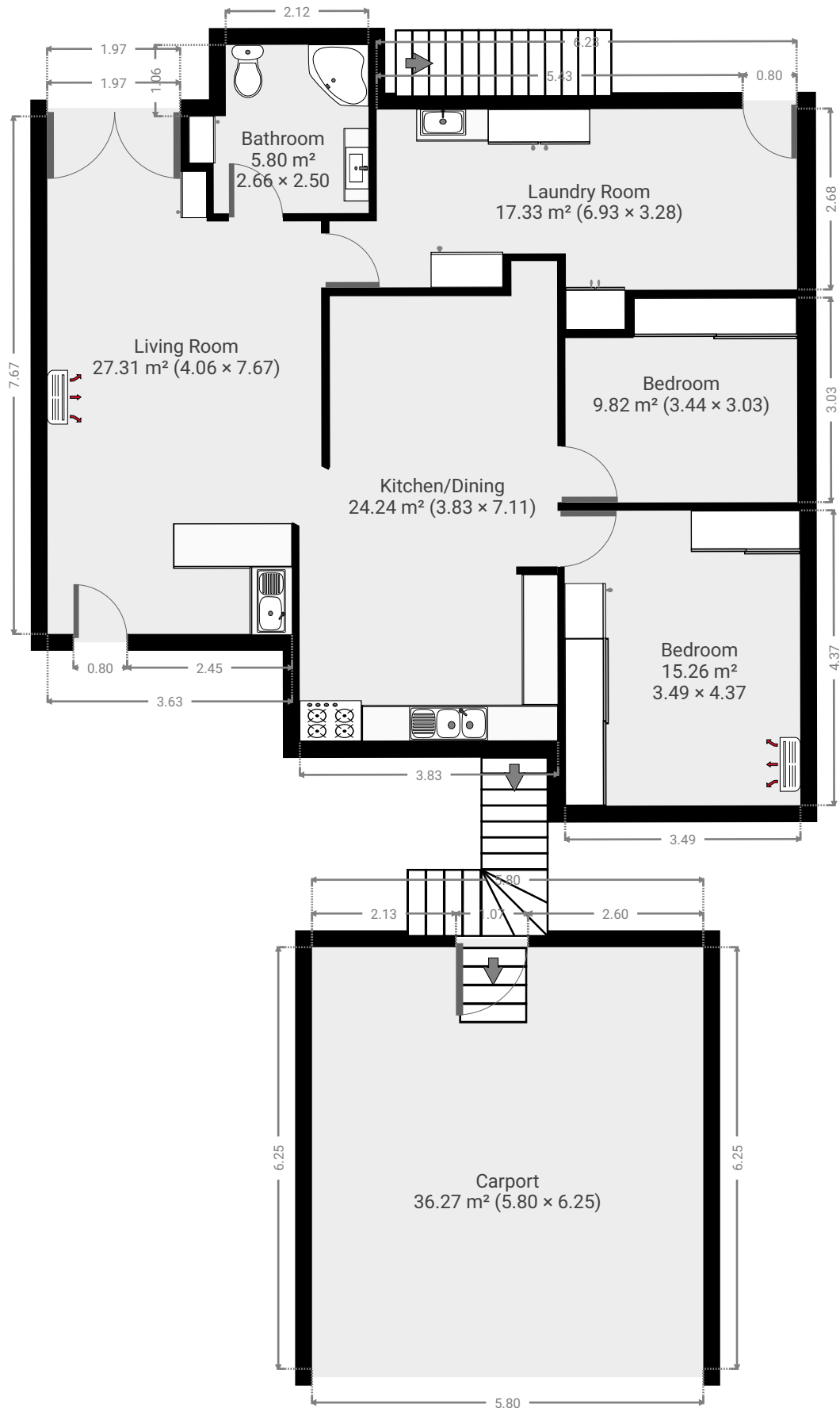

▼ **Bedroom**
Ground Floor

WIDTH: 3.49 m • LENGTH: 4.37 m
AREA: 15.26 m² • PERIMETER: 15.72 m

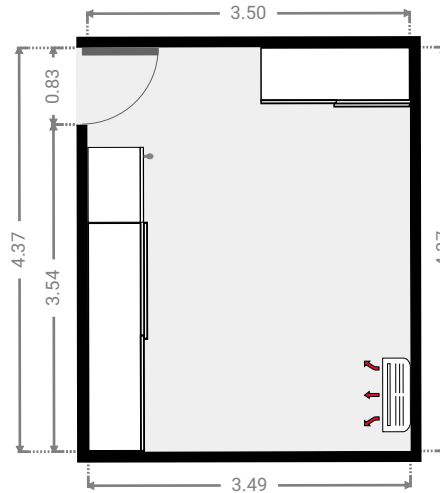
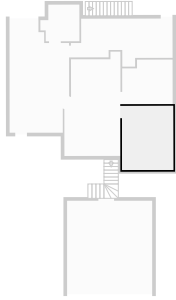

▼ **Kitchen/Dining**
Ground Floor

WIDTH: 3.83 m • LENGTH: 7.11 m
AREA: 24.24 m² • PERIMETER: 21.54 m

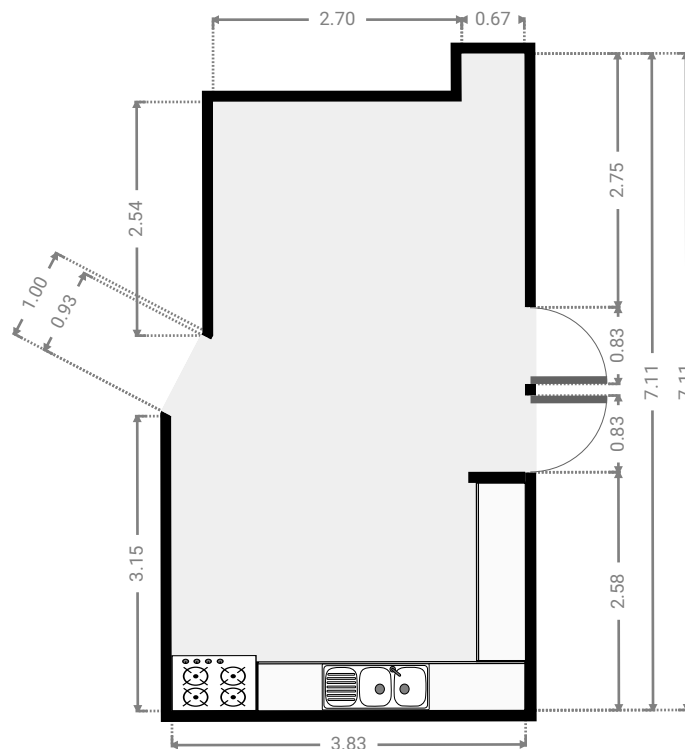
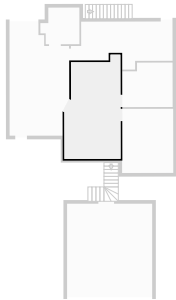

▼ Living Room
Ground Floor

WIDTH: 4.06 m • LENGTH: 7.67 m
AREA: 27.31 m² • PERIMETER: 23.14 m

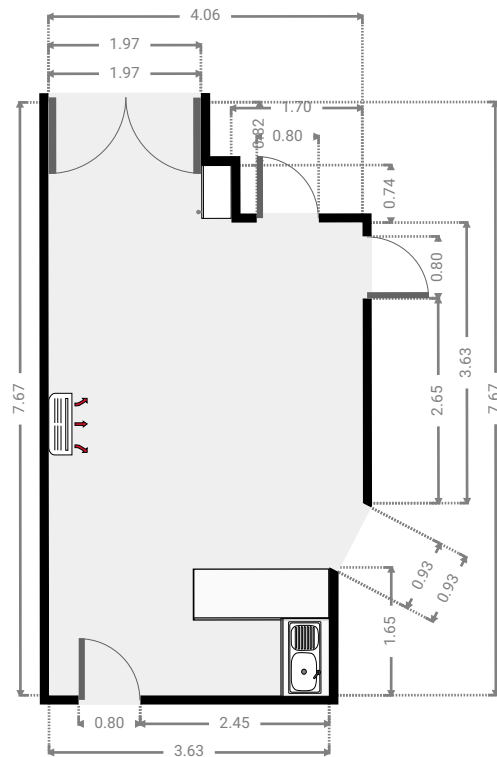
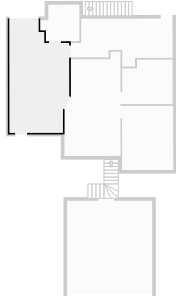

▼ Bedroom
Ground Floor

WIDTH: 3.44 m • LENGTH: 3.03 m
AREA: 9.82 m² • PERIMETER: 12.94 m

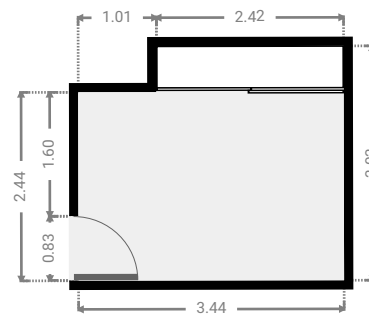
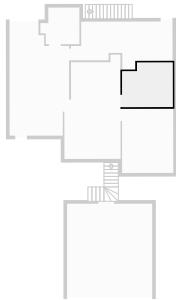

▼ Bathroom
Ground Floor

WIDTH: 2.66 m • LENGTH: 2.50 m
AREA: 5.80 m² • PERIMETER: 10.32 m

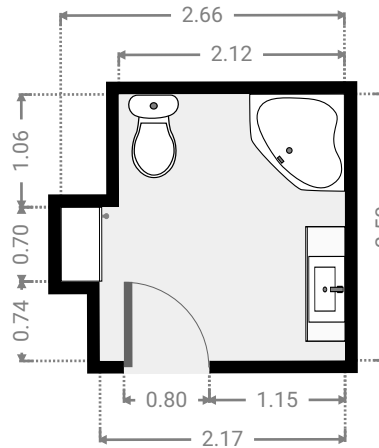
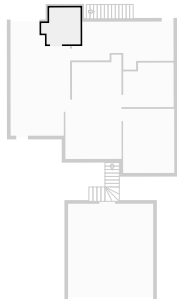

▼ Laundry Room
Ground Floor

WIDTH: 6.93 m • LENGTH: 3.28 m
AREA: 17.33 m² • PERIMETER: 21.41 m

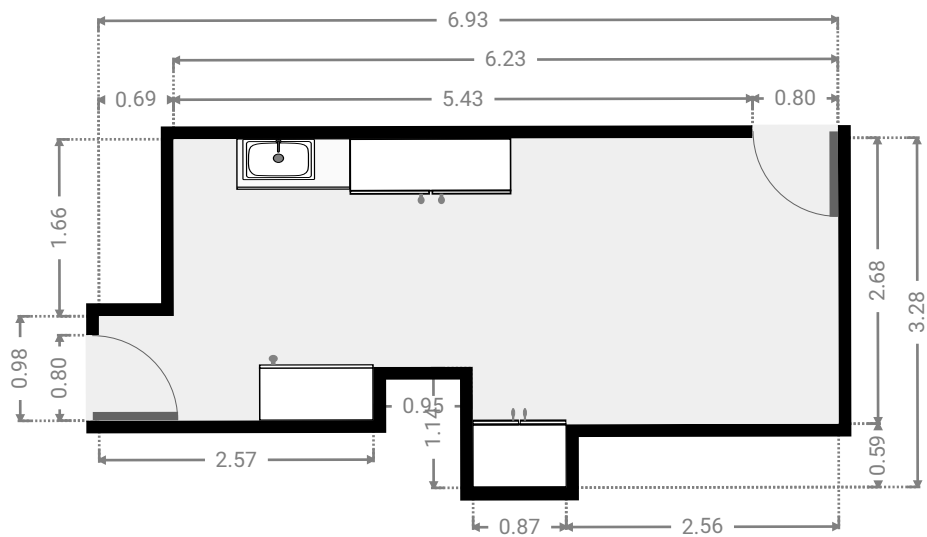
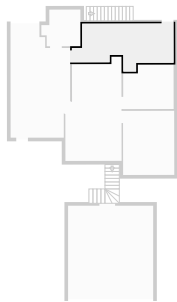

▼ Carport
Ground Floor

WIDTH: 5.80 m • LENGTH: 6.25 m
AREA: 36.27 m² • PERIMETER: 24.11 m

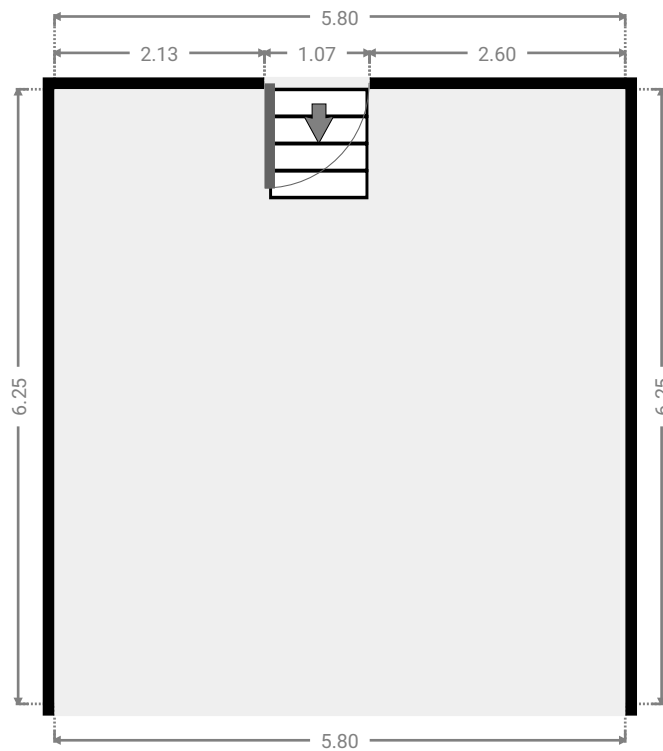
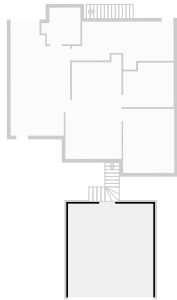

▼ 1st Floor



▼ Sunroom
1st Floor

WIDTH: 3.65 m • LENGTH: 2.26 m
AREA: 8.27 m² • PERIMETER: 11.83 m

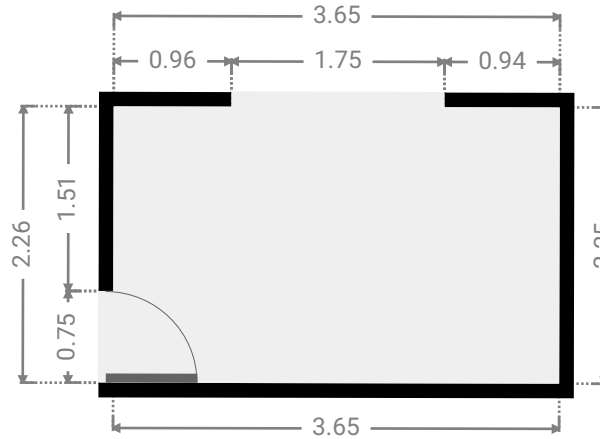
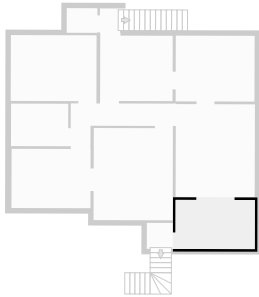

▼ Living Room
1st Floor

WIDTH: 3.65 m • LENGTH: 4.28 m
AREA: 15.60 m² • PERIMETER: 15.85 m

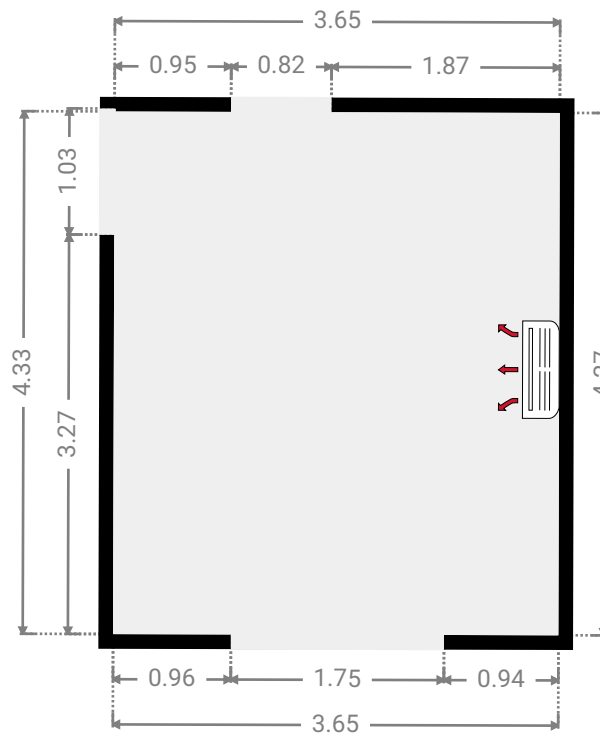
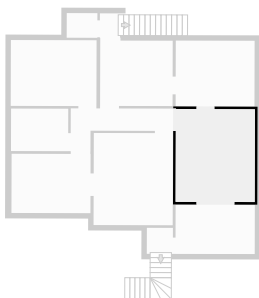

▼ **Hall**
1st Floor

WIDTH: 4.74 m • LENGTH: 1.99 m
AREA: 5.75 m² • PERIMETER: 13.46 m

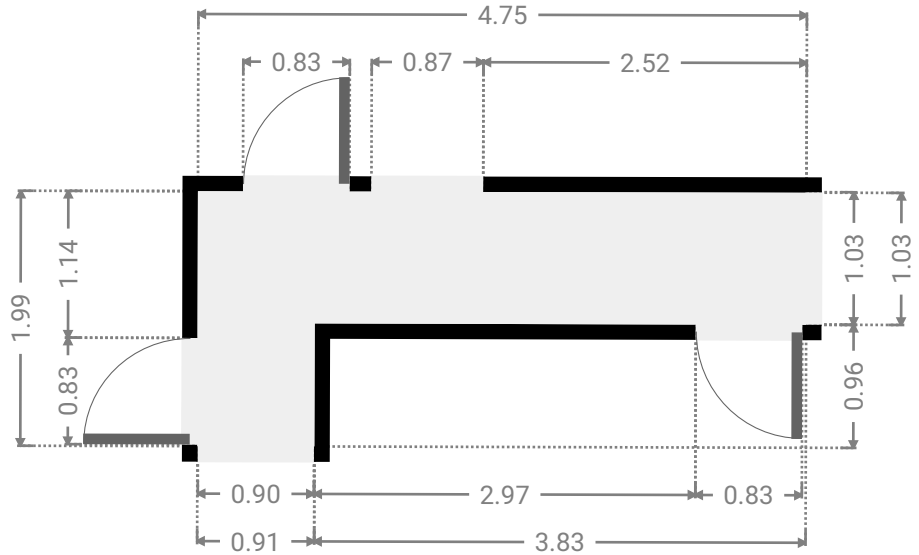
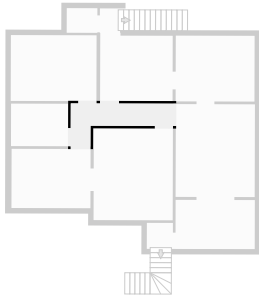

▼ **Bedroom**
1st Floor

WIDTH: 3.64 m • LENGTH: 2.73 m
AREA: 9.94 m² • PERIMETER: 12.74 m

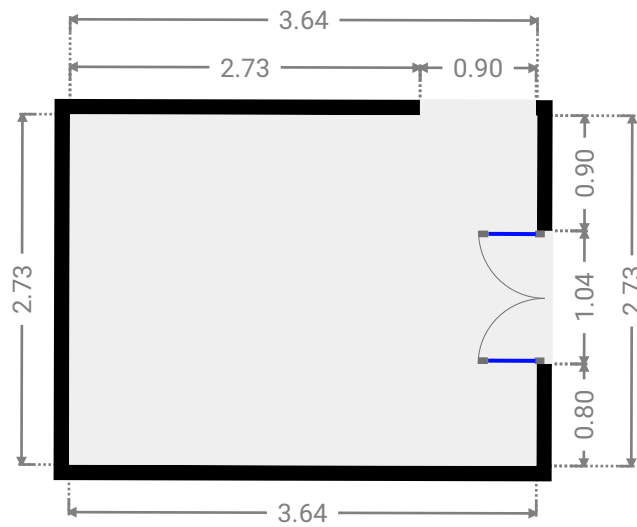
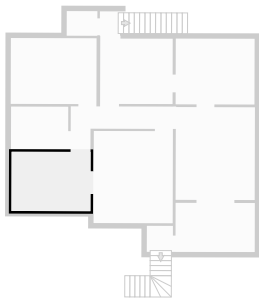

▼ Bathroom
1st Floor

WIDTH: 2.64 m • LENGTH: 1.96 m
AREA: 5.17 m² • PERIMETER: 9.19 m

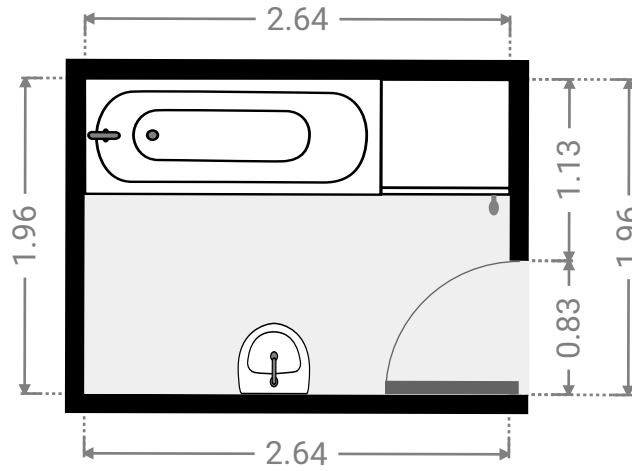
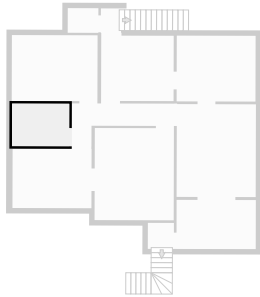

▼ Bedroom
1st Floor

WIDTH: 3.95 m • LENGTH: 3.04 m
AREA: 12.00 m² • PERIMETER: 13.98 m

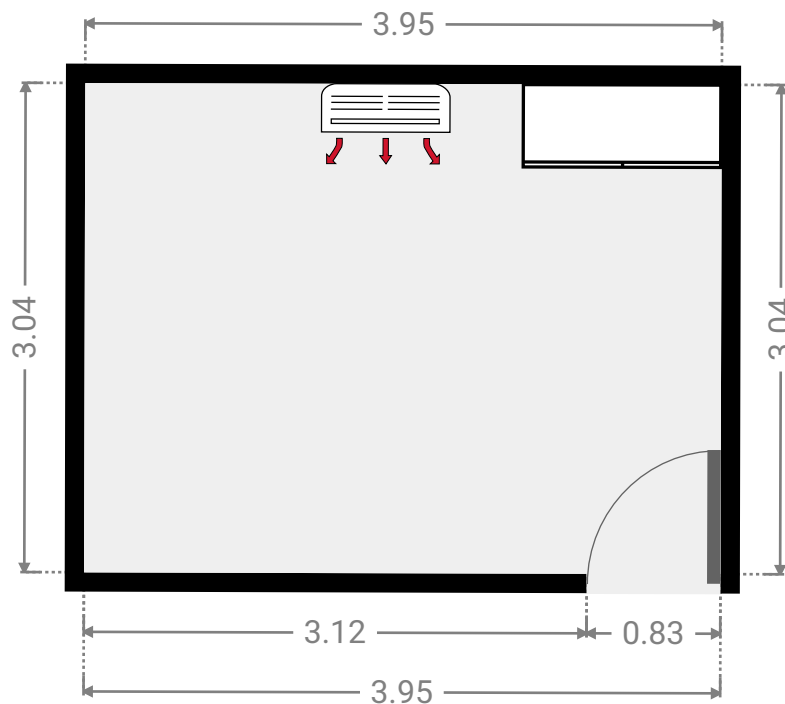
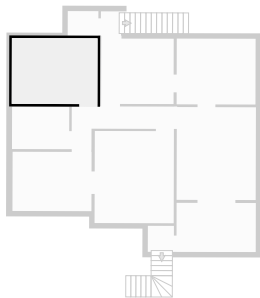

▼ **Kitchen**
1st Floor

WIDTH: 3.34 m • LENGTH: 3.01 m
AREA: 10.07 m² • PERIMETER: 12.71 m

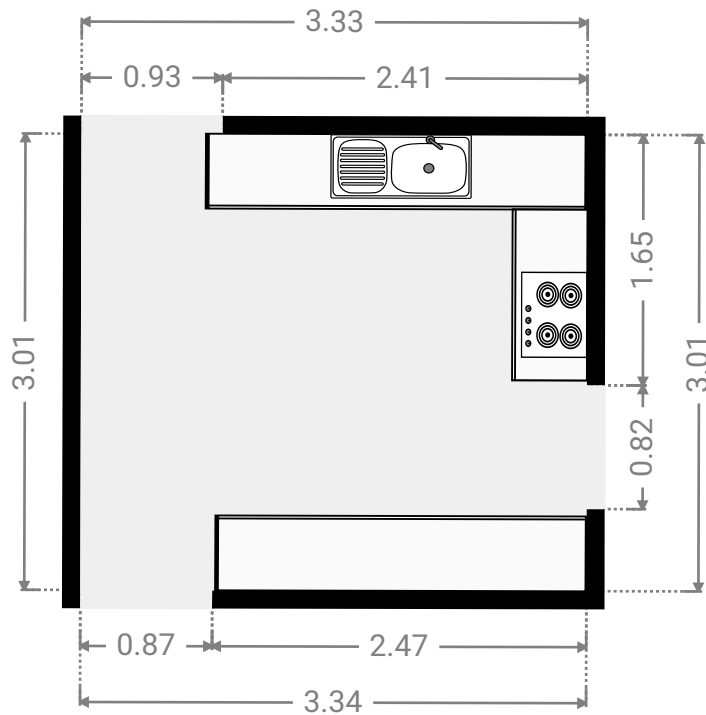
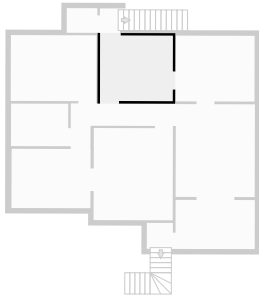

▼ **Dining Room**
1st Floor

WIDTH: 3.64 m • LENGTH: 3.03 m
AREA: 11.02 m² • PERIMETER: 13.33 m

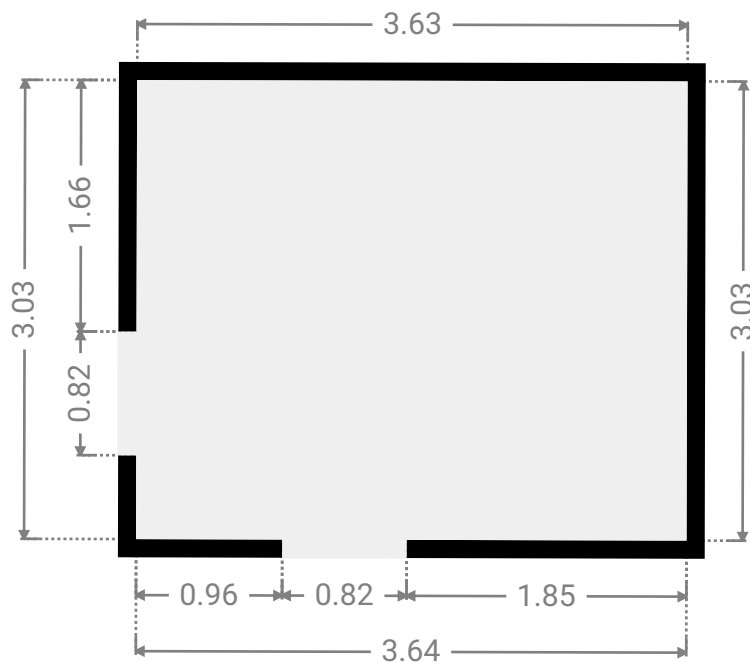
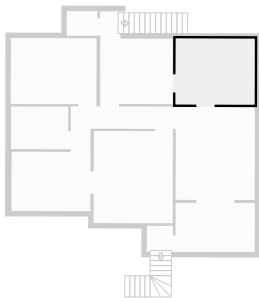

▼ Master Bedroom
1st Floor

WIDTH: 3.65 m • LENGTH: 4.25 m
AREA: 15.49 m² • PERIMETER: 15.79 m

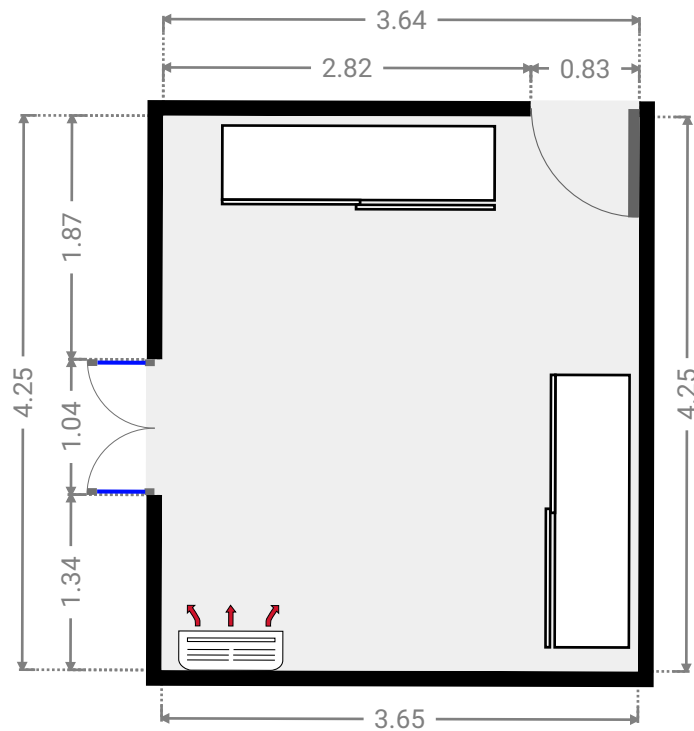
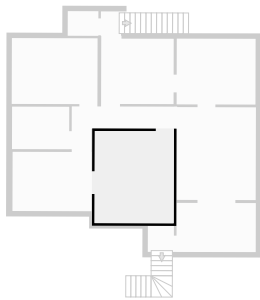

▼ .
1st Floor

WIDTH: 0.93 m • LENGTH: 1.13 m
AREA: 1.05 m² • PERIMETER: 4.12 m

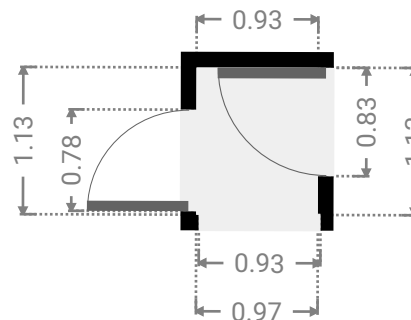
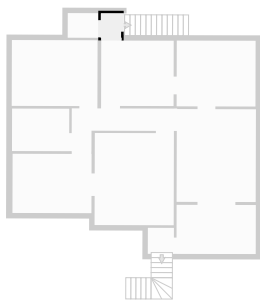

▼ **Toilet**
1st Floor

WIDTH: 1.41 m • LENGTH: 1.14 m
AREA: 1.60 m² • PERIMETER: 5.10 m

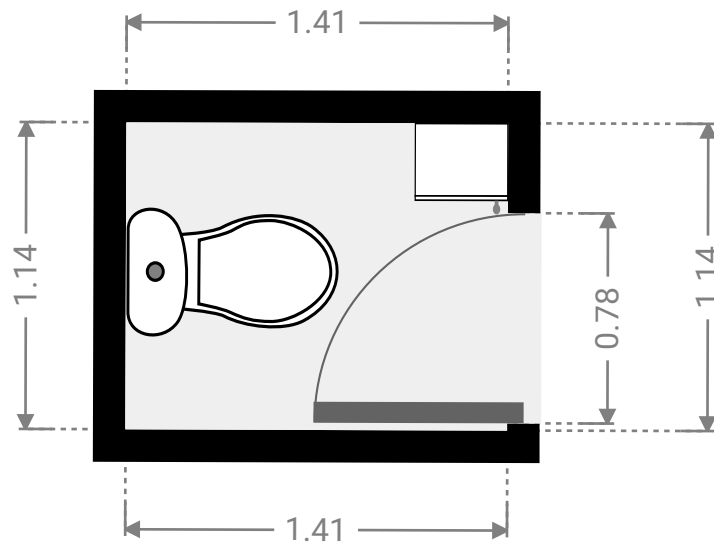
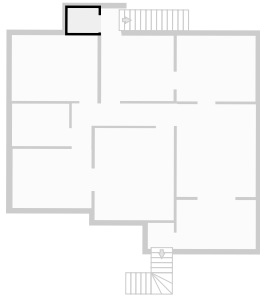

▼ **Entry**
1st Floor

WIDTH: 1.20 m • LENGTH: 1.20 m
AREA: 1.44 m² • PERIMETER: 4.80 m

