

# 261 Noel Street

**SUBMITTED BY**

Ray White Rockhampton Casey  
stockers@cqoz.com

---

**CREATED ON**

2022-04-06

---

**Floors**

2

---

▼ Ground Floor

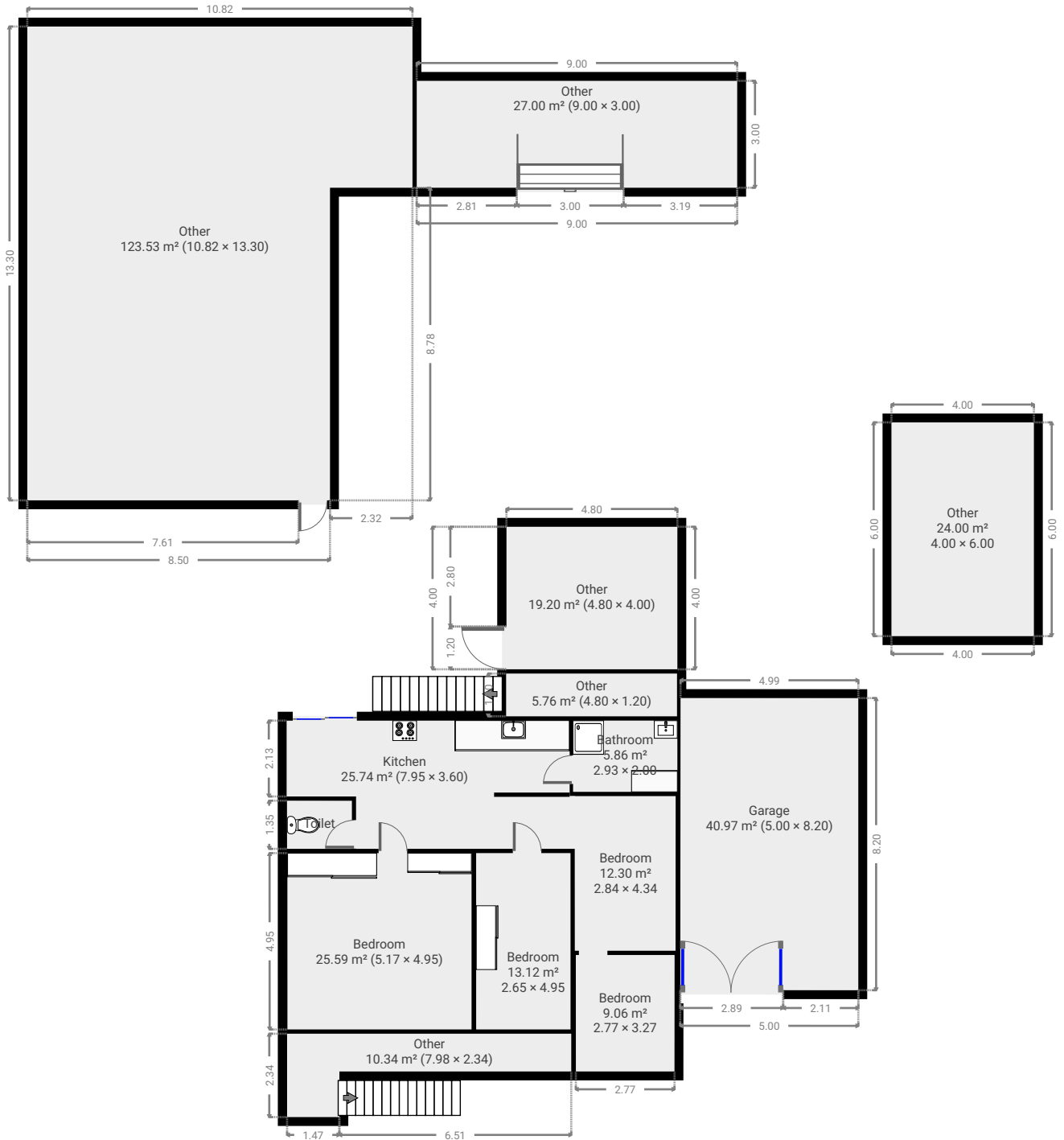

▼ **Bedroom**  
Ground Floor

WIDTH: 2.77 m • LENGTH: 3.27 m  
AREA: 9.06 m<sup>2</sup> • PERIMETER: 12.08 m

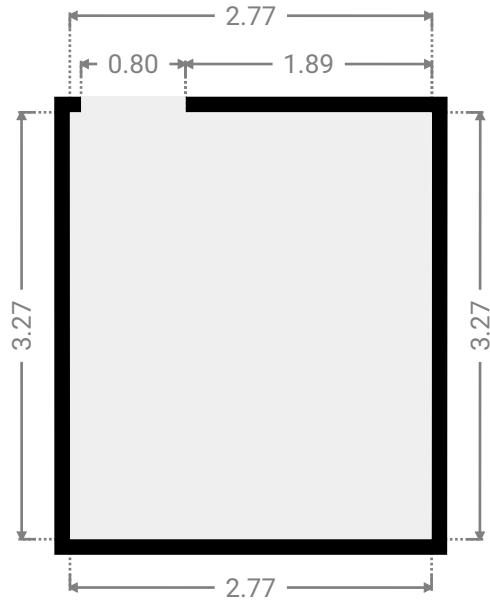
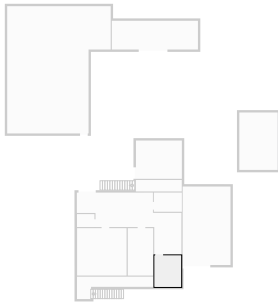

▼ **Bedroom**  
Ground Floor

WIDTH: 2.84 m • LENGTH: 4.34 m  
AREA: 12.30 m<sup>2</sup> • PERIMETER: 14.35 m

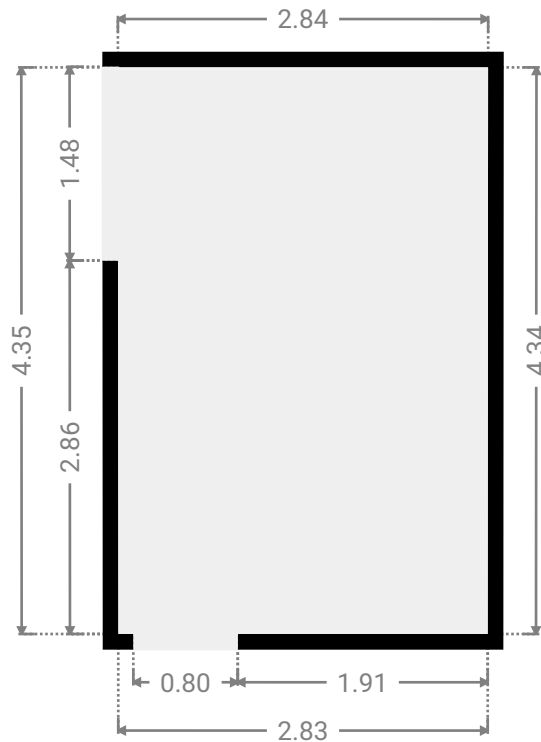
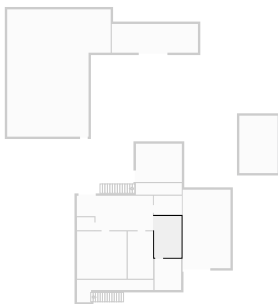

▼ Bathroom  
Ground Floor

WIDTH: 2.93 m • LENGTH: 2.00 m  
AREA: 5.86 m<sup>2</sup> • PERIMETER: 9.86 m

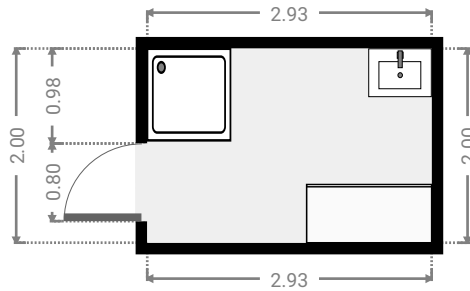
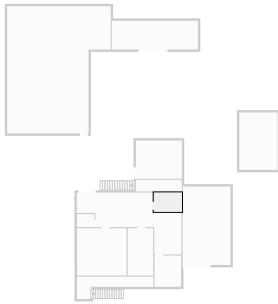

▼ Kitchen  
Ground Floor

WIDTH: 7.95 m • LENGTH: 3.60 m  
AREA: 25.74 m<sup>2</sup> • PERIMETER: 23.09 m

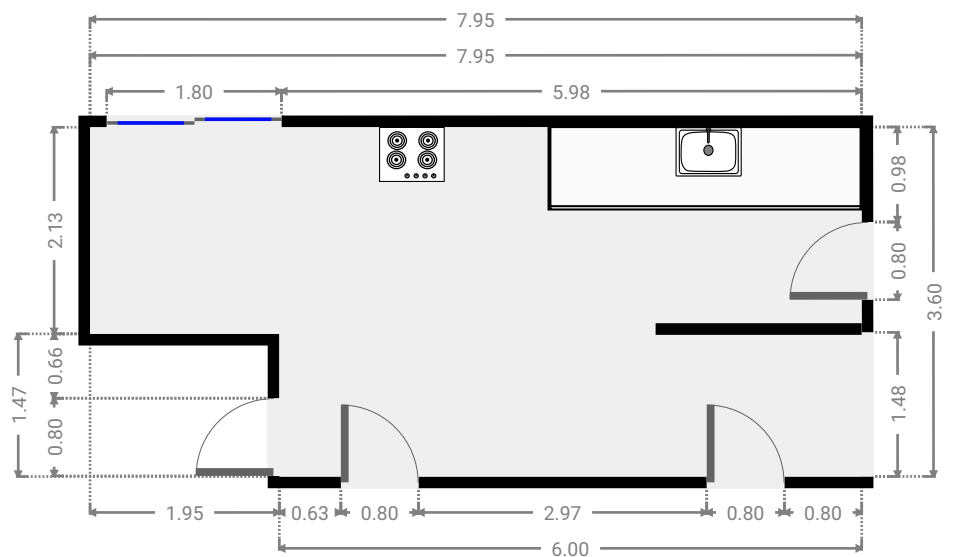
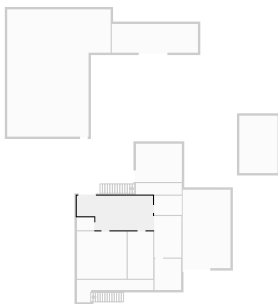

▼ **Bedroom**  
Ground Floor

WIDTH: 2.65 m • LENGTH: 4.95 m  
AREA: 13.12 m<sup>2</sup> • PERIMETER: 15.20 m

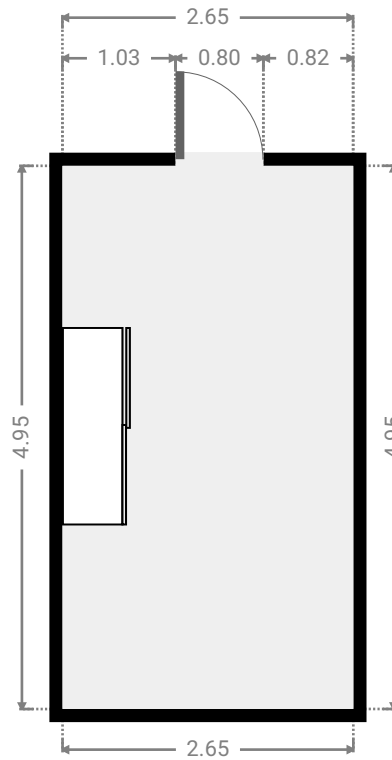
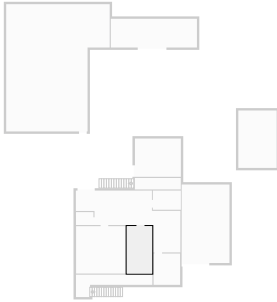

▼ **Bedroom**  
Ground Floor

WIDTH: 5.17 m • LENGTH: 4.95 m  
AREA: 25.59 m<sup>2</sup> • PERIMETER: 20.24 m

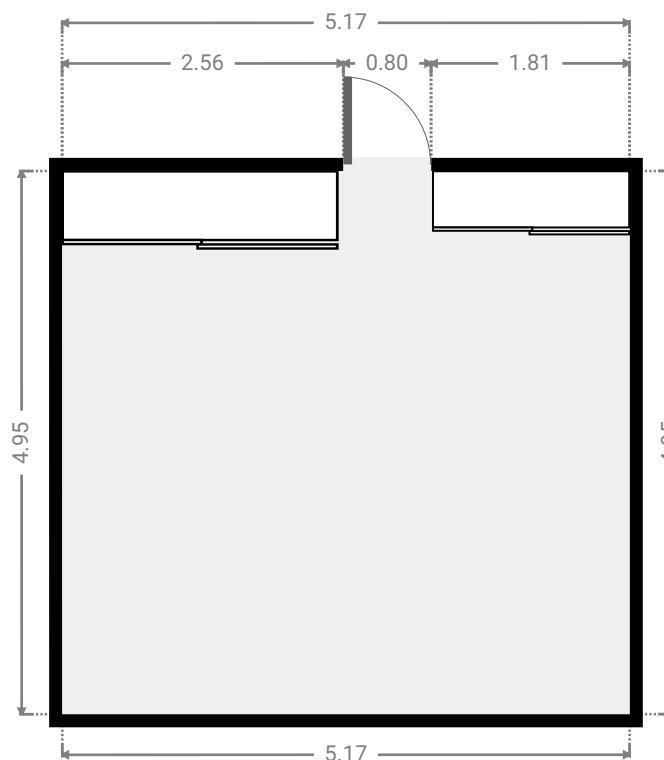
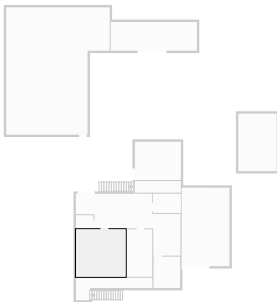

▼ **Toilet**  
Ground Floor

WIDTH: 1.82 m • LENGTH: 1.35 m  
AREA: 2.46 m<sup>2</sup> • PERIMETER: 6.34 m

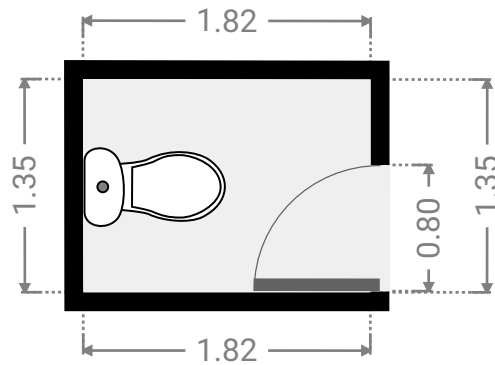
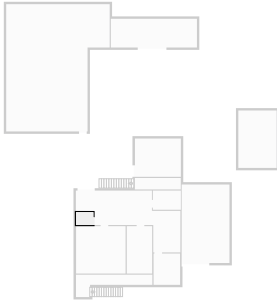

▼ **Other**  
Ground Floor

WIDTH: 4.80 m • LENGTH: 1.20 m  
AREA: 5.76 m<sup>2</sup> • PERIMETER: 12.00 m

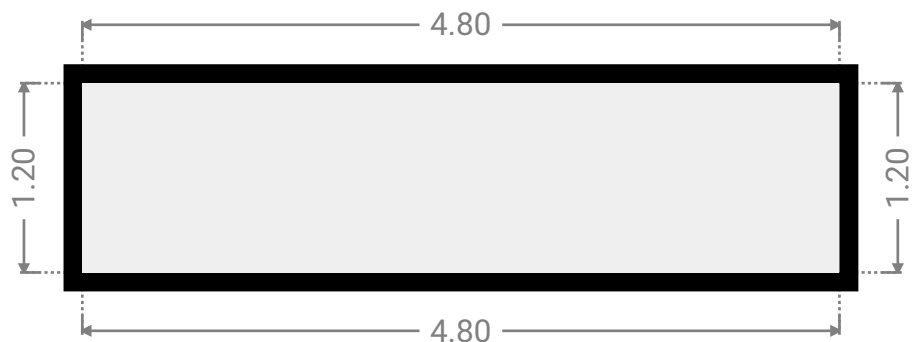
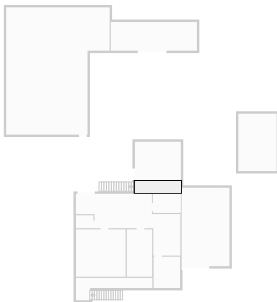

▼ Other  
Ground Floor

WIDTH: 4.80 m • LENGTH: 4.00 m  
AREA: 19.20 m<sup>2</sup> • PERIMETER: 17.60 m

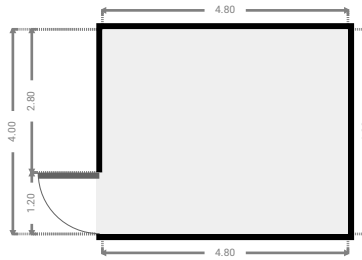
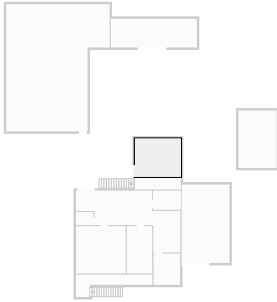

▼ Other  
Ground Floor

WIDTH: 10.82 m • LENGTH: 13.30 m  
AREA: 123.53 m<sup>2</sup> • PERIMETER: 48.23 m

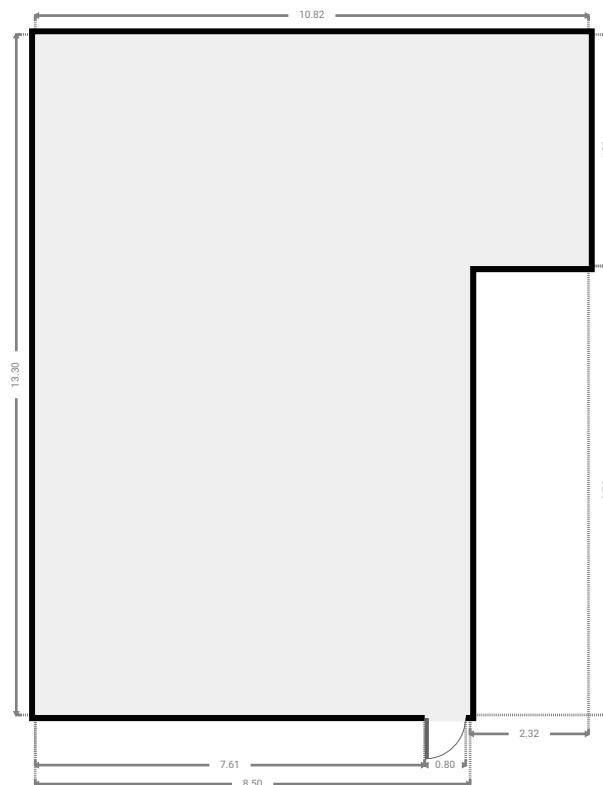
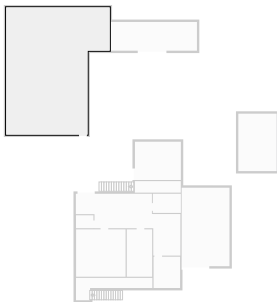

▼ Other  
Ground Floor

WIDTH: 9.00 m • LENGTH: 3.00 m  
AREA: 27.00 m<sup>2</sup> • PERIMETER: 24.00 m

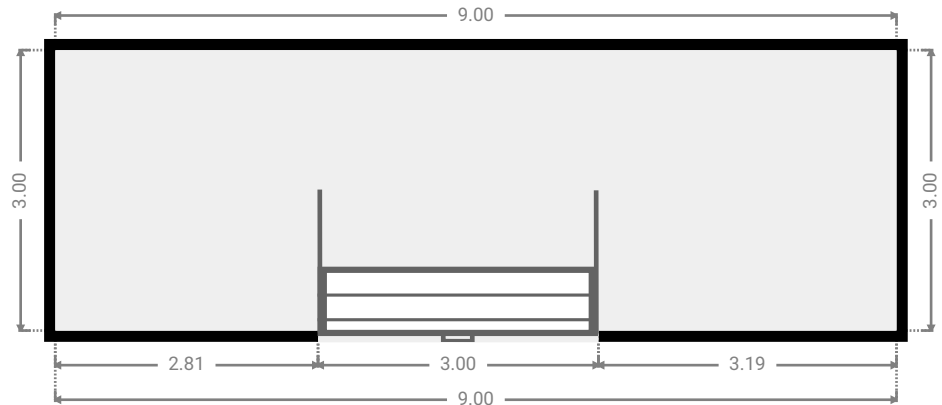
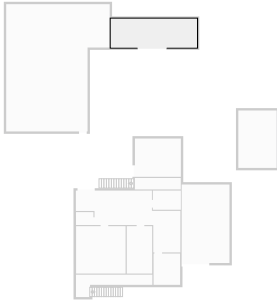

▼ Other  
Ground Floor

WIDTH: 4.00 m • LENGTH: 6.00 m  
AREA: 24.00 m<sup>2</sup> • PERIMETER: 20.00 m

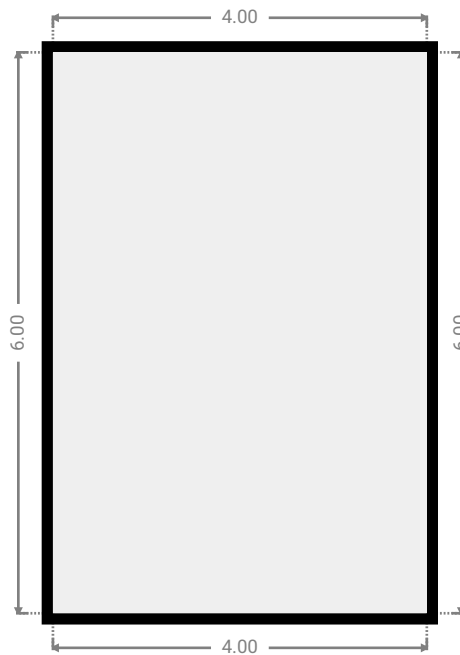
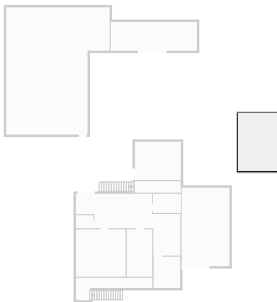



▼ **Garage**  
Ground Floor

WIDTH: 5.00 m • LENGTH: 8.20 m  
AREA: 40.97 m<sup>2</sup> • PERIMETER: 26.39 m

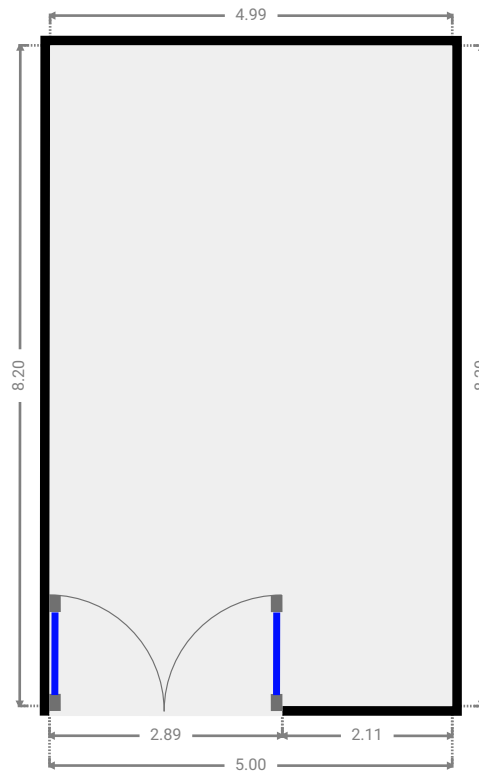
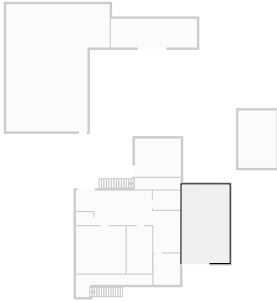

▼ **Other**  
Ground Floor

WIDTH: 7.98 m • LENGTH: 2.34 m  
AREA: 10.34 m<sup>2</sup> • PERIMETER: 20.64 m

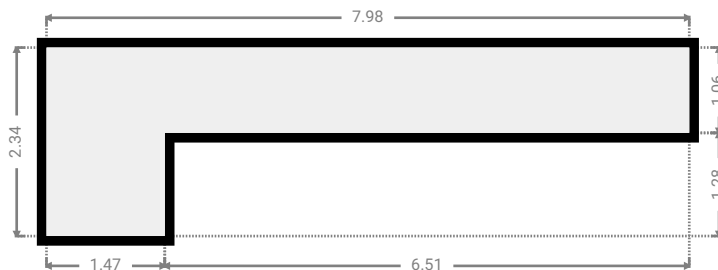
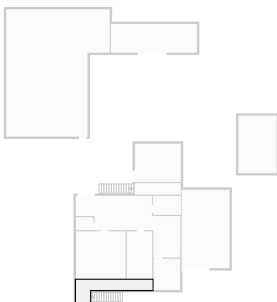

## ▼ 1st Floor

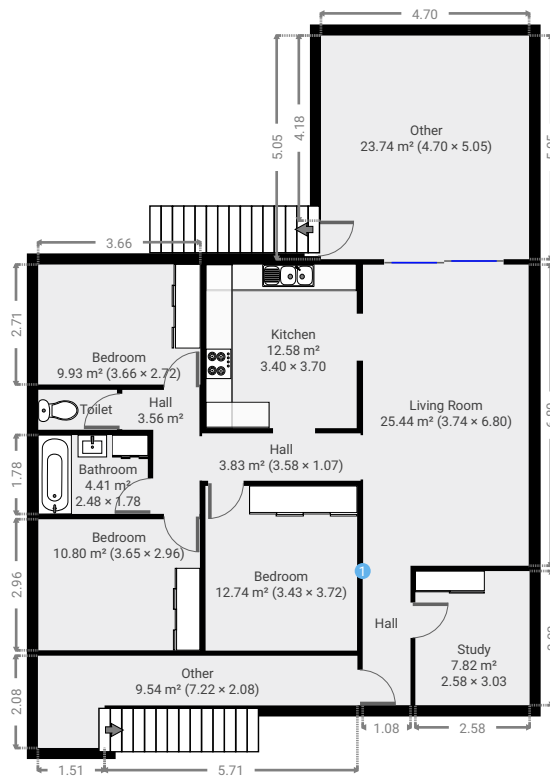

▼ **Hall**  
1st Floor

WIDTH: 1.08 m • LENGTH: 3.03 m  
AREA: 3.27 m<sup>2</sup> • PERIMETER: 8.22 m

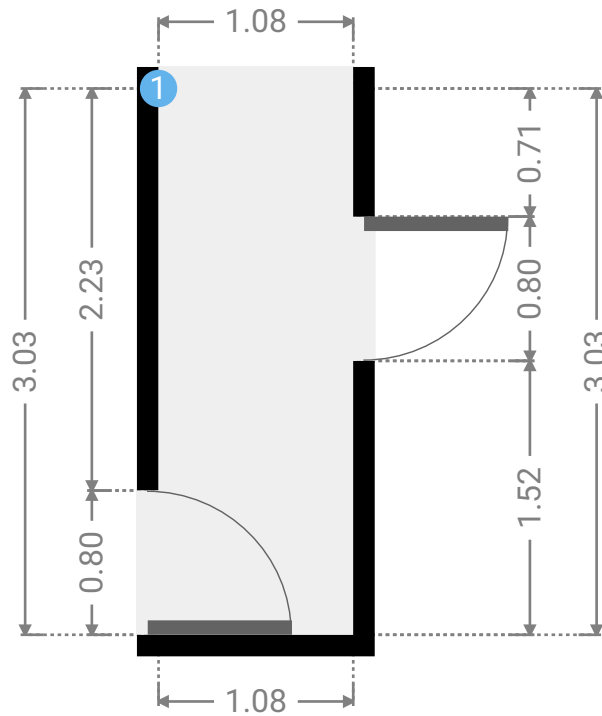
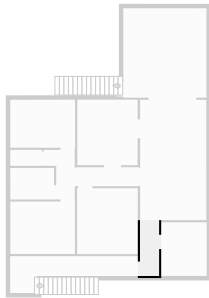

▼ **Hall/1st Floor**

**1** OPENING

Height  
0.00 m



▼ Study  
1st Floor

WIDTH: 2.58 m • LENGTH: 3.03 m  
AREA: 7.82 m<sup>2</sup> • PERIMETER: 11.22 m

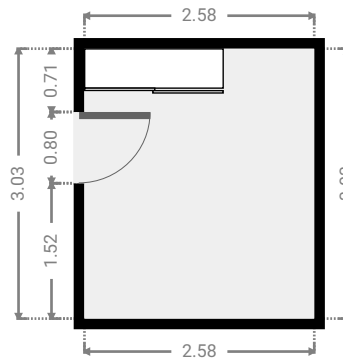
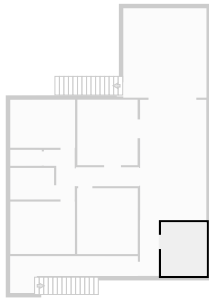

▼ Living Room  
1st Floor

WIDTH: 3.74 m • LENGTH: 6.80 m  
AREA: 25.44 m<sup>2</sup> • PERIMETER: 21.08 m

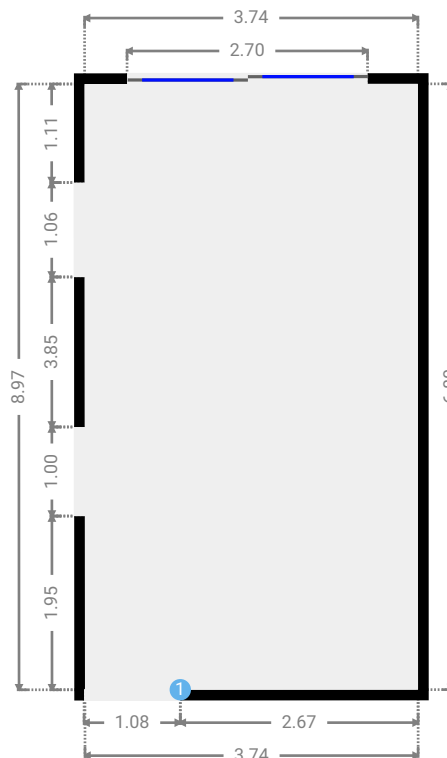
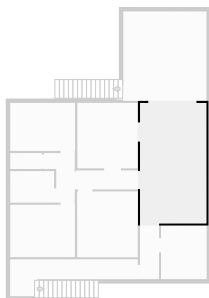

▼ **Hall**  
1st Floor

WIDTH: 3.58 m • LENGTH: 1.07 m  
AREA: 3.83 m<sup>2</sup> • PERIMETER: 9.30 m

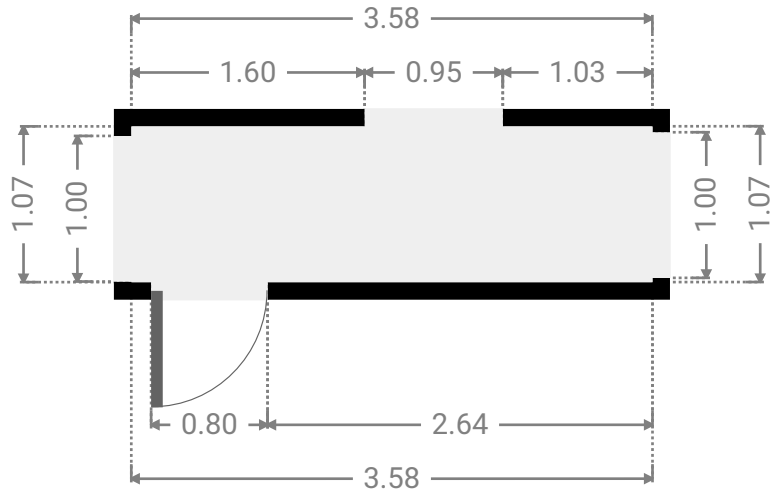

▼ **Kitchen**  
1st Floor

WIDTH: 3.40 m • LENGTH: 3.70 m  
AREA: 12.58 m<sup>2</sup> • PERIMETER: 14.20 m

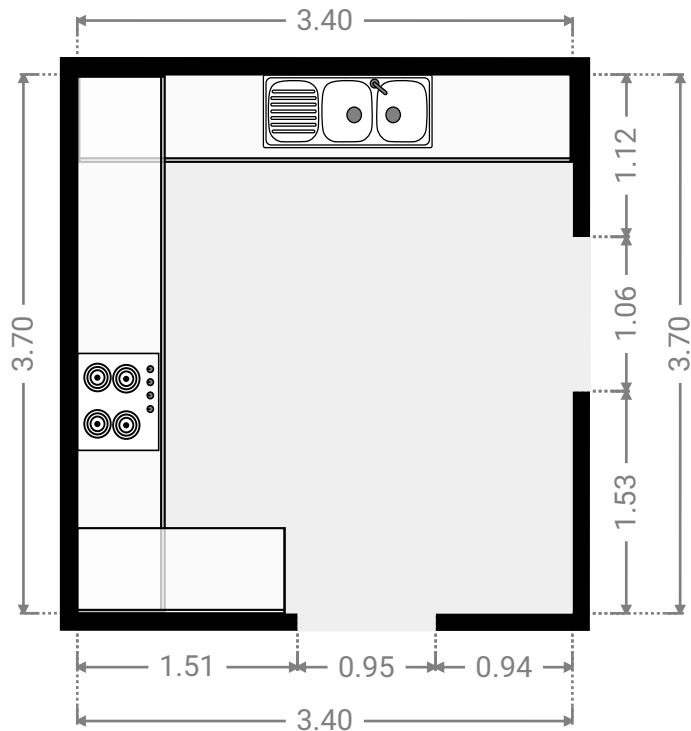
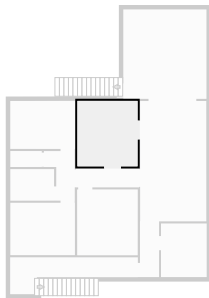

▼ **Bedroom**  
1st Floor

WIDTH: 3.42 m • LENGTH: 3.72 m  
AREA: 12.74 m<sup>2</sup> • PERIMETER: 14.29 m

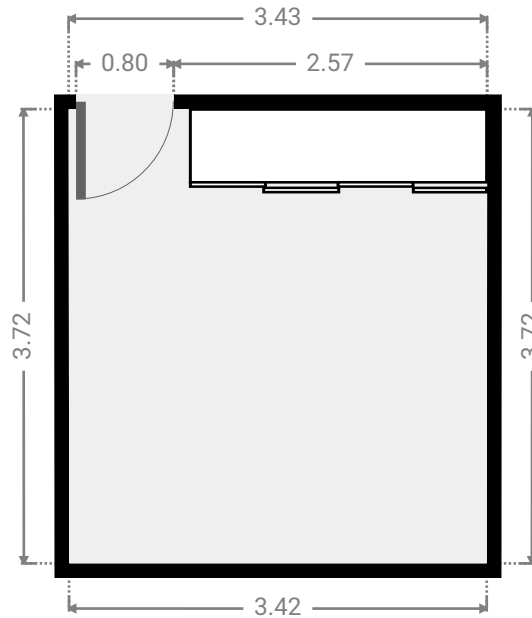
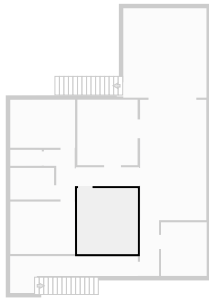

▼ **Hall**  
1st Floor

WIDTH: 1.75 m • LENGTH: 2.80 m  
AREA: 3.56 m<sup>2</sup> • PERIMETER: 9.09 m

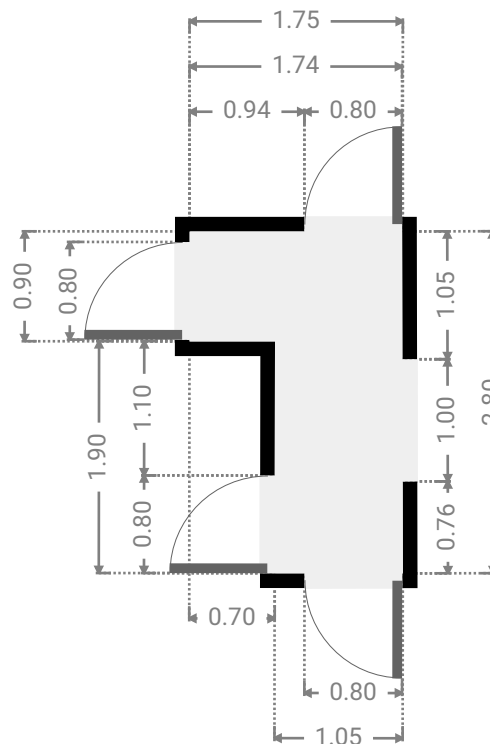
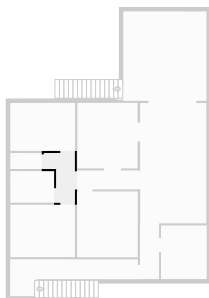

▼ **Bedroom**  
1st Floor

WIDTH: 3.65 m • LENGTH: 2.96 m  
AREA: 10.80 m<sup>2</sup> • PERIMETER: 13.22 m

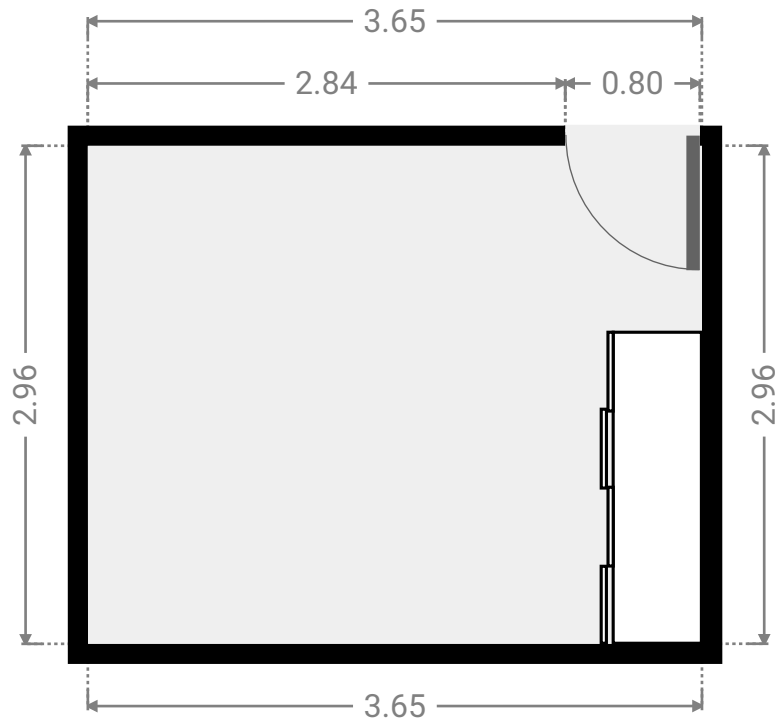
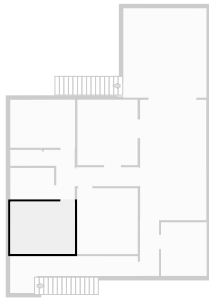

▼ **Bathroom**  
1st Floor

WIDTH: 2.48 m • LENGTH: 1.78 m  
AREA: 4.41 m<sup>2</sup> • PERIMETER: 8.51 m

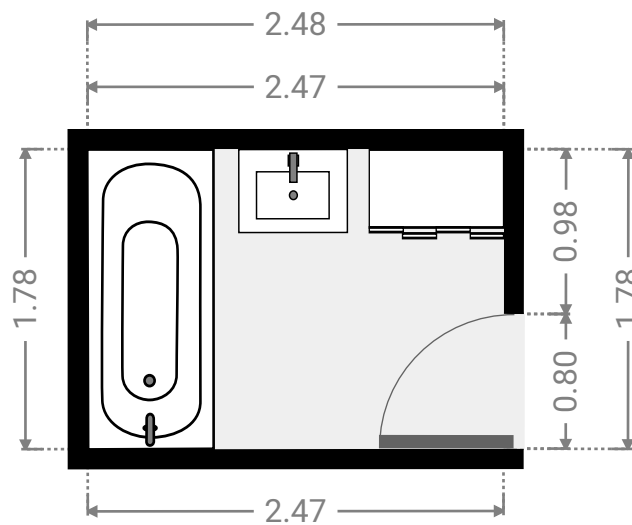
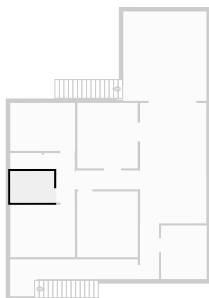

▼ **Toilet**  
1st Floor

WIDTH: 1.78 m • LENGTH: 0.90 m  
AREA: 1.60 m<sup>2</sup> • PERIMETER: 5.36 m

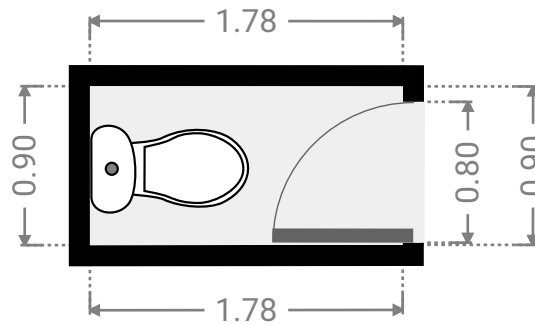

▼ **Bedroom**  
1st Floor

WIDTH: 3.66 m • LENGTH: 2.72 m  
AREA: 9.93 m<sup>2</sup> • PERIMETER: 12.75 m

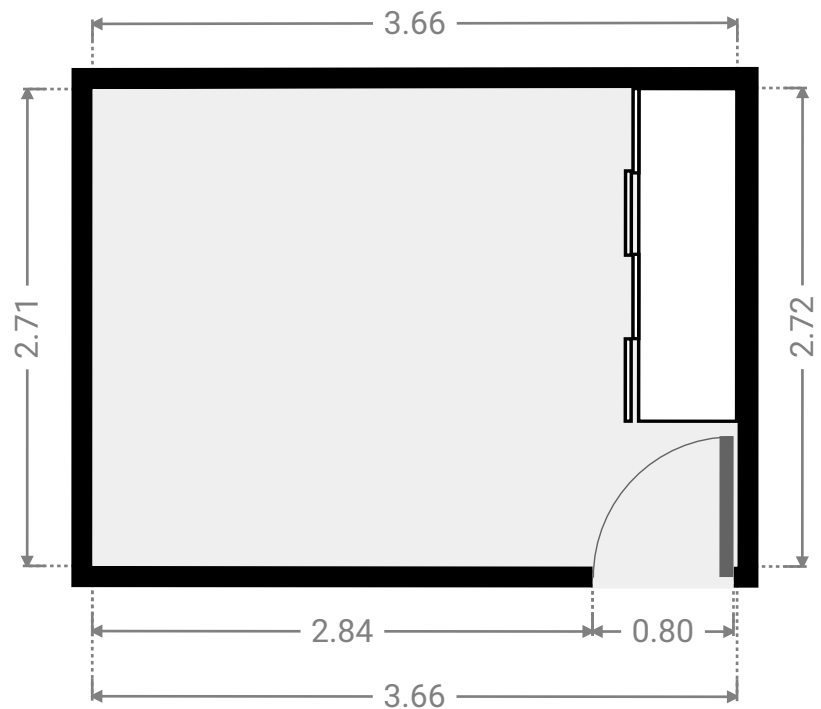
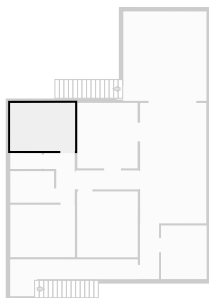



▼ Other  
1st Floor

WIDTH: 4.70 m • LENGTH: 5.05 m  
AREA: 23.74 m<sup>2</sup> • PERIMETER: 19.50 m

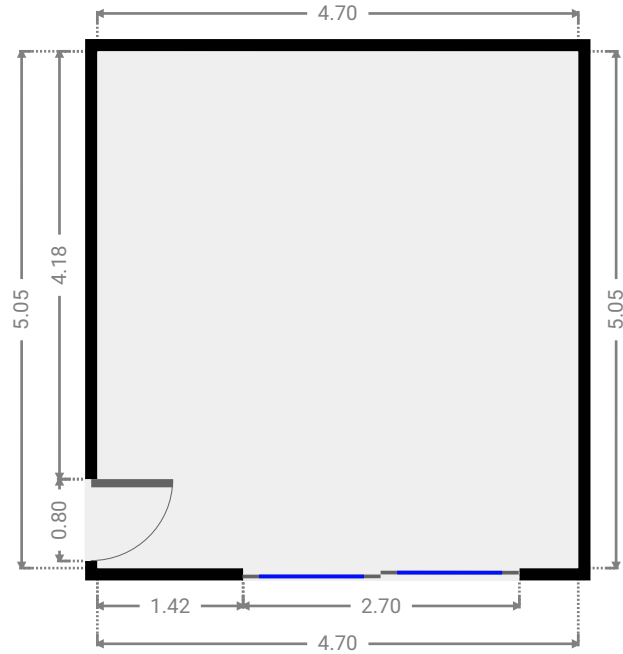
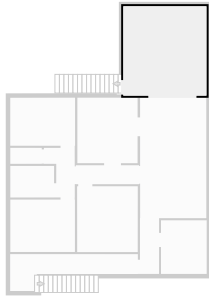

▼ Other  
1st Floor

WIDTH: 7.22 m • LENGTH: 2.08 m  
AREA: 9.54 m<sup>2</sup> • PERIMETER: 18.60 m

