

260 Diplock Street

SUBMITTED BY

Ray White Rockhampton Casey
stockers@cqoz.com

CREATED ON

2022-01-19

Floors

2

▼ Ground Floor

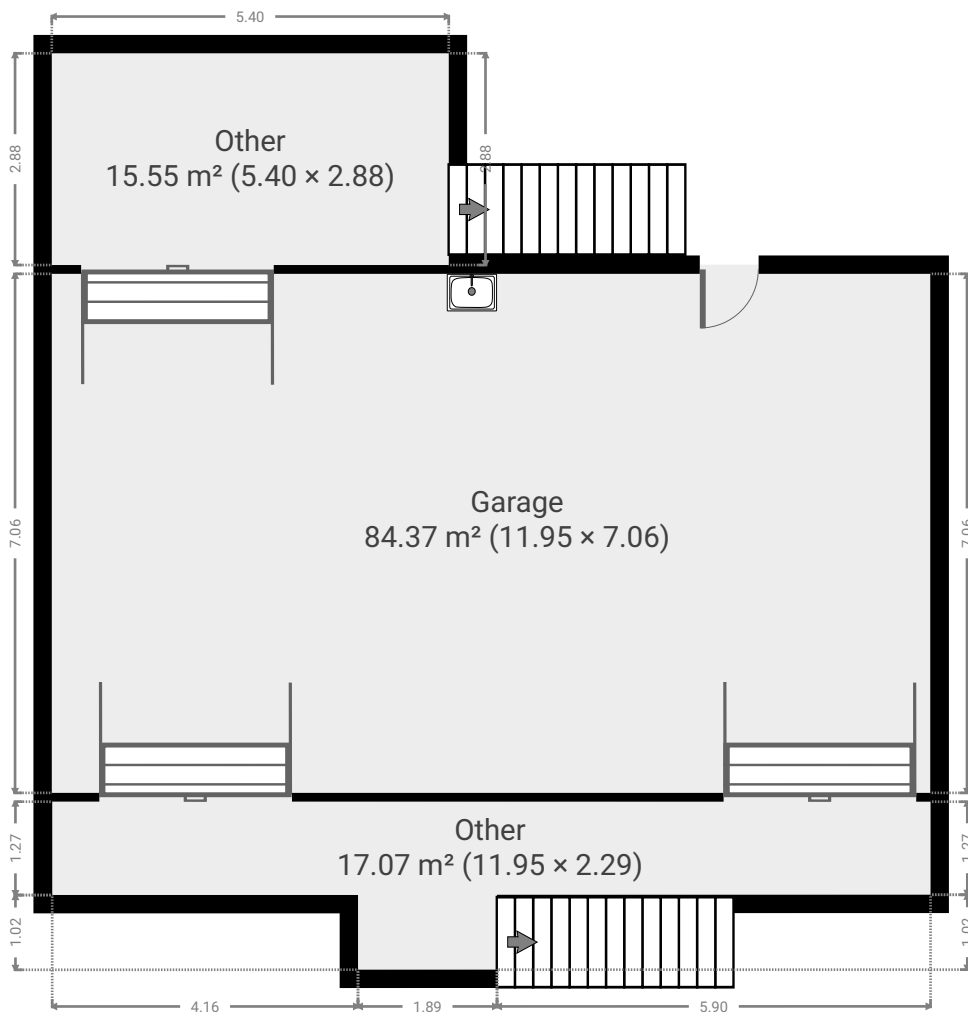
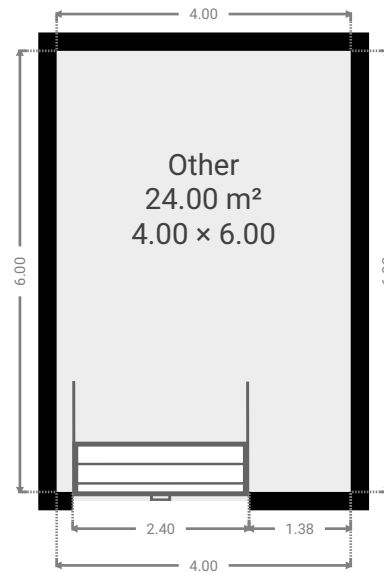

▼ **Garage**
Ground Floor

WIDTH: 11.95 m • LENGTH: 7.06 m
AREA: 84.37 m² • PERIMETER: 38.02 m

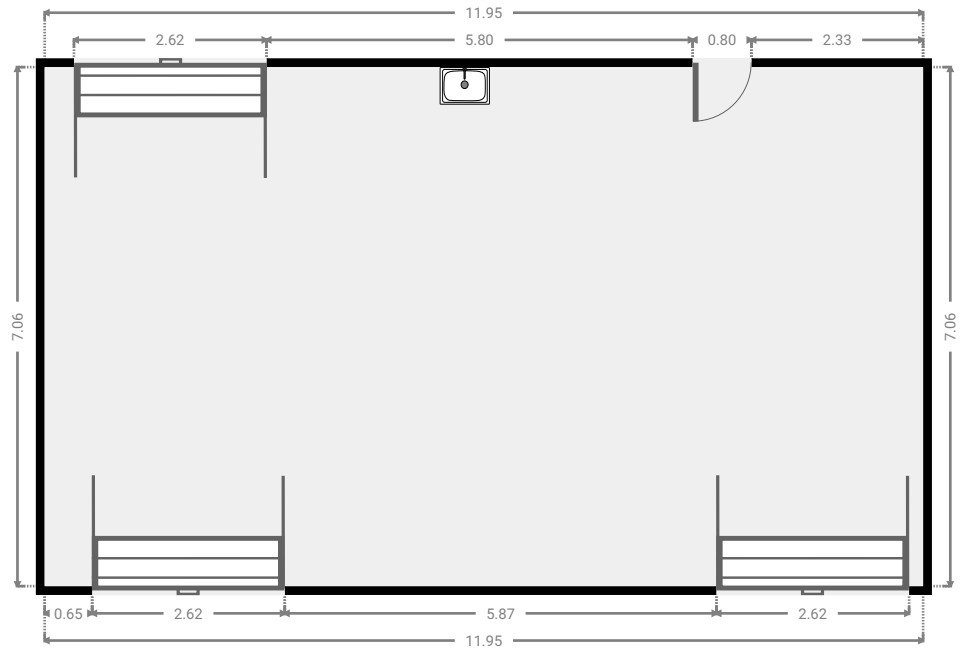
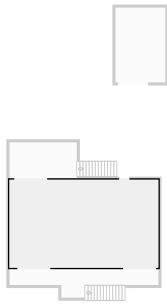

▼ **Other**
Ground Floor

WIDTH: 5.40 m • LENGTH: 2.88 m
AREA: 15.55 m² • PERIMETER: 16.56 m

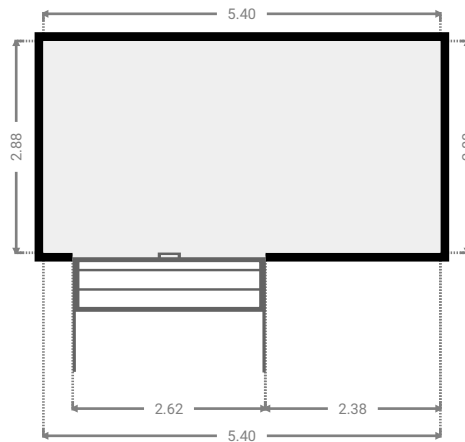
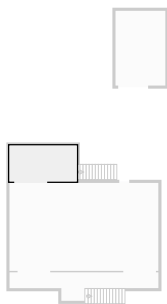

▼ **Other**
Ground Floor

WIDTH: 4.00 m • LENGTH: 6.00 m
AREA: 24.00 m² • PERIMETER: 20.00 m

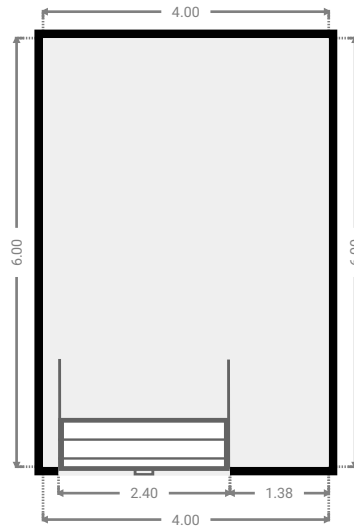
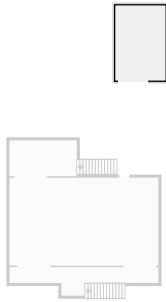

▼ **Other**
Ground Floor

WIDTH: 11.95 m • LENGTH: 2.29 m
AREA: 17.07 m² • PERIMETER: 28.47 m

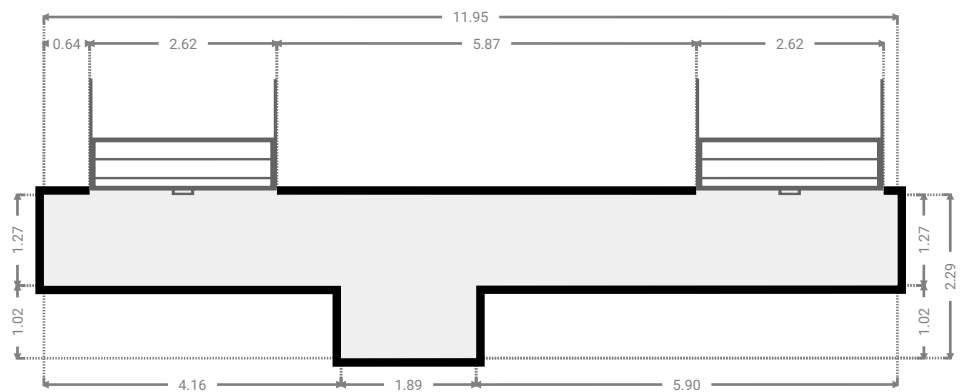
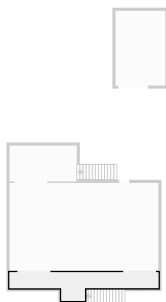

▼ 1st Floor

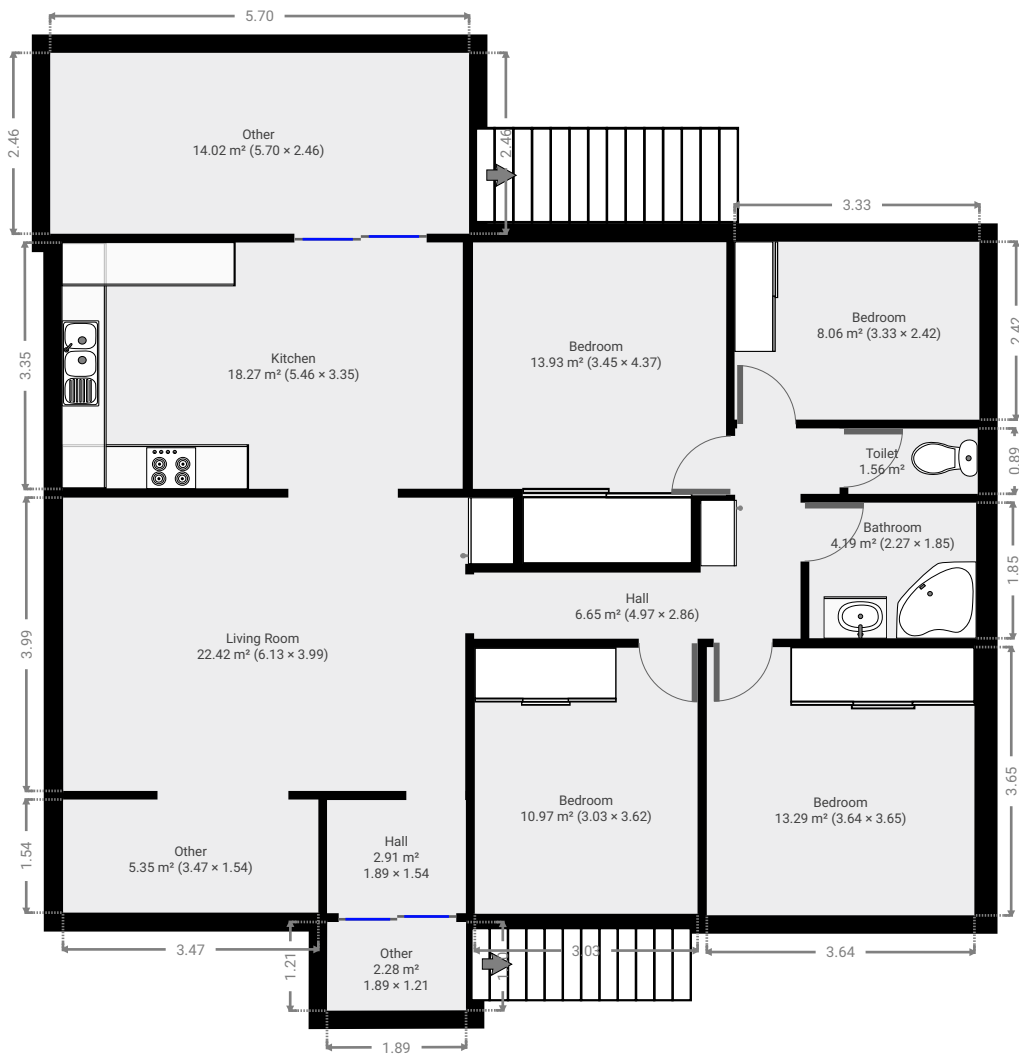

▼ Hall
1st Floor

WIDTH: 1.89 m • LENGTH: 1.54 m
AREA: 2.91 m² • PERIMETER: 6.86 m

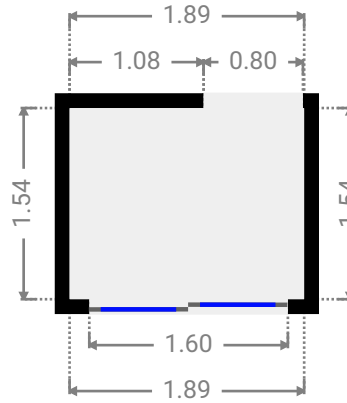

▼ Living Room
1st Floor

WIDTH: 6.13 m • LENGTH: 3.99 m
AREA: 22.42 m² • PERIMETER: 20.24 m

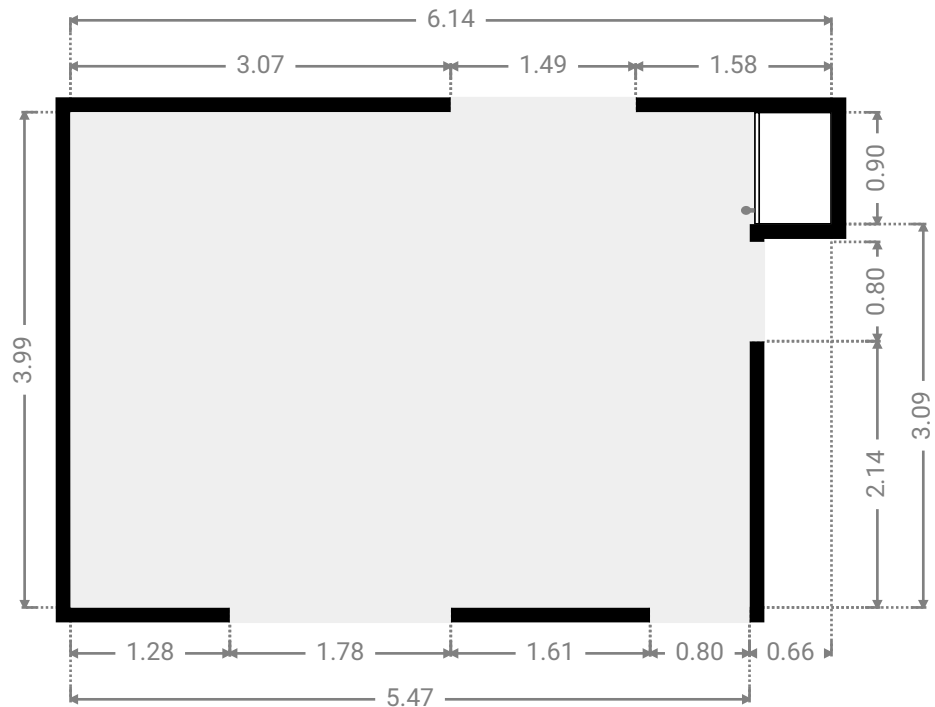
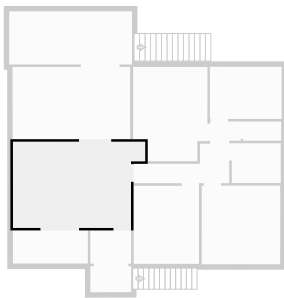

▼ **Other**
1st Floor

WIDTH: 3.47 m • LENGTH: 1.54 m
AREA: 5.35 m² • PERIMETER: 10.03 m

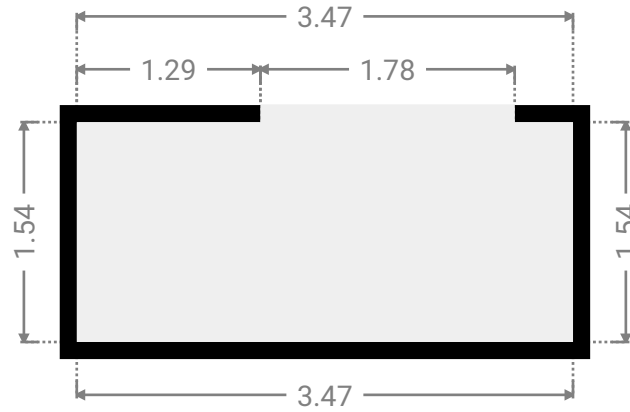
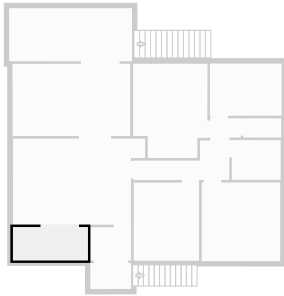

▼ **Kitchen**
1st Floor

WIDTH: 5.46 m • LENGTH: 3.35 m
AREA: 18.27 m² • PERIMETER: 17.61 m

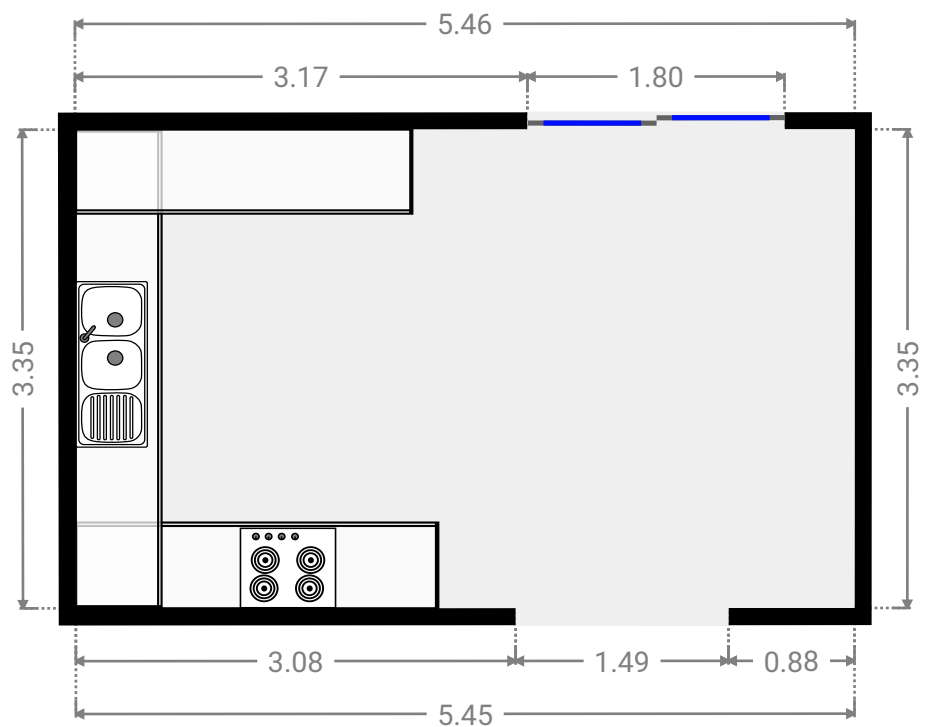
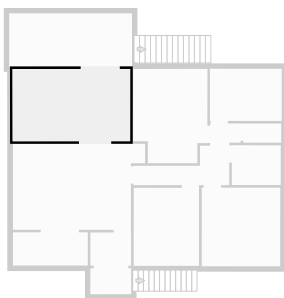

▼ **Hall**
1st Floor

WIDTH: 4.97 m • LENGTH: 2.86 m
AREA: 6.65 m² • PERIMETER: 15.66 m

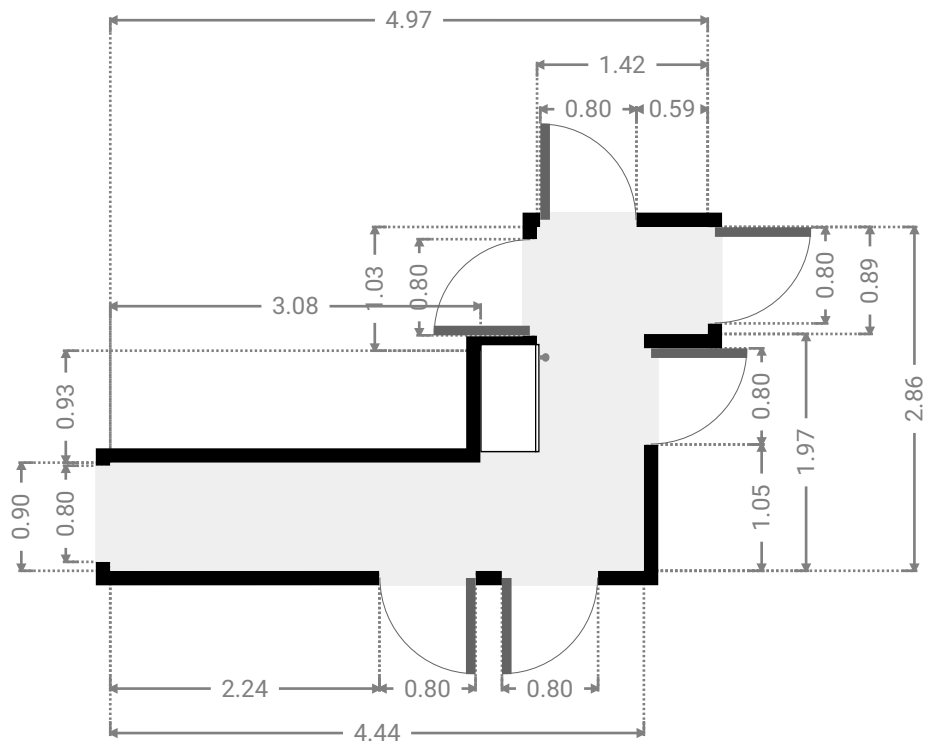
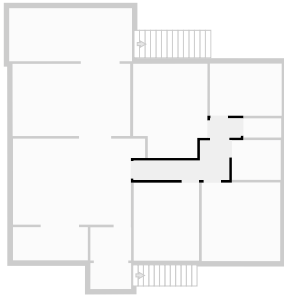

▼ **Bedroom**
1st Floor

WIDTH: 3.03 m • LENGTH: 3.62 m
AREA: 10.97 m² • PERIMETER: 13.30 m

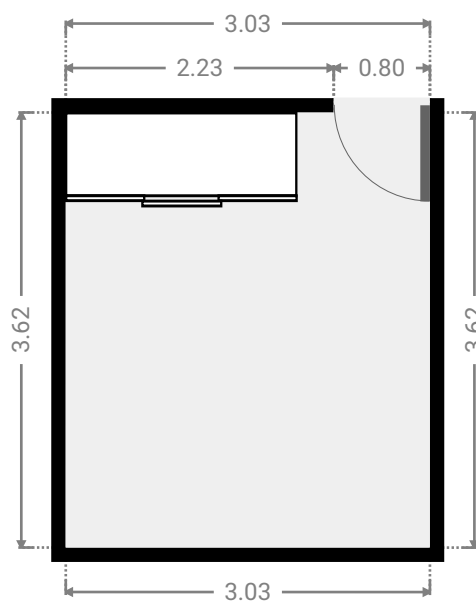
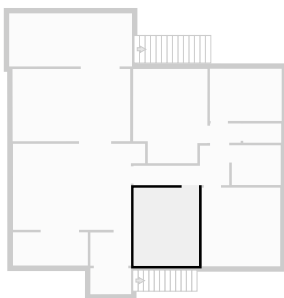

▼ **Bedroom**
1st Floor

WIDTH: 3.64 m • LENGTH: 3.65 m
AREA: 13.29 m² • PERIMETER: 14.58 m

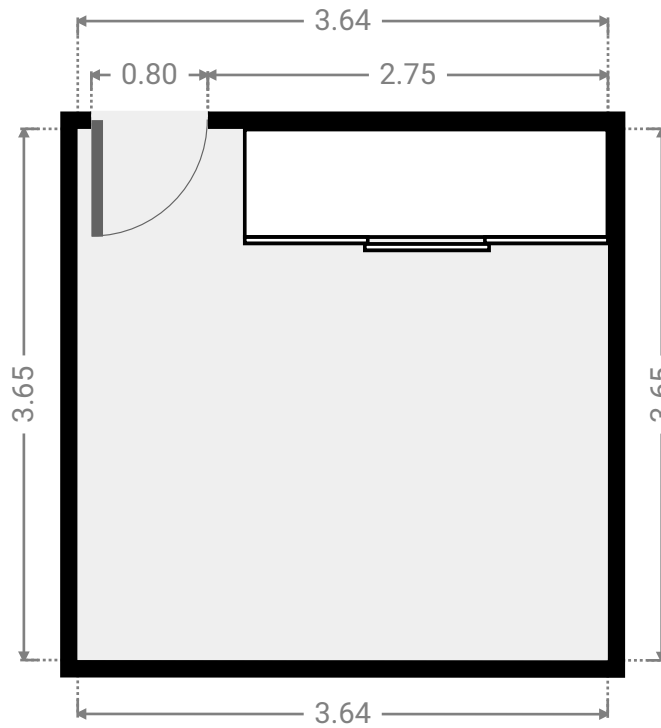
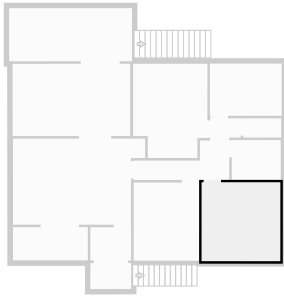

▼ **Bathroom**
1st Floor

WIDTH: 2.27 m • LENGTH: 1.85 m
AREA: 4.19 m² • PERIMETER: 8.23 m

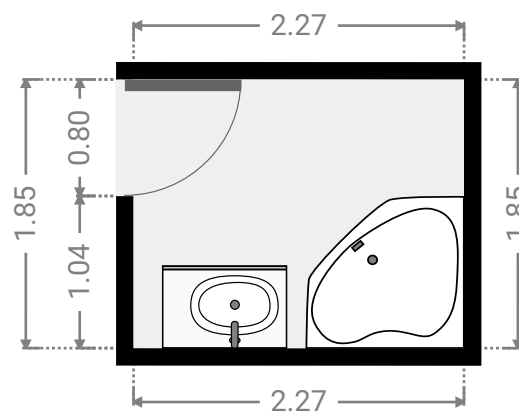
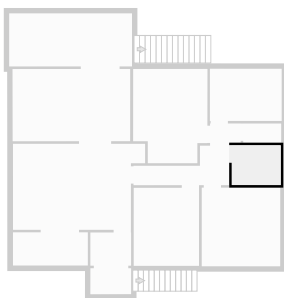

▼ **Toilet**
1st Floor

WIDTH: 1.76 m • LENGTH: 0.89 m
AREA: 1.56 m² • PERIMETER: 5.30 m

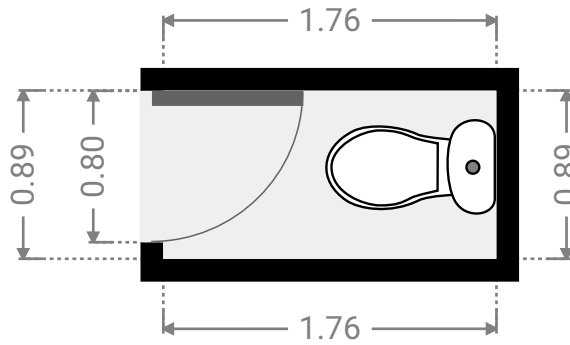

▼ **Bedroom**
1st Floor

WIDTH: 3.33 m • LENGTH: 2.42 m
AREA: 8.06 m² • PERIMETER: 11.50 m

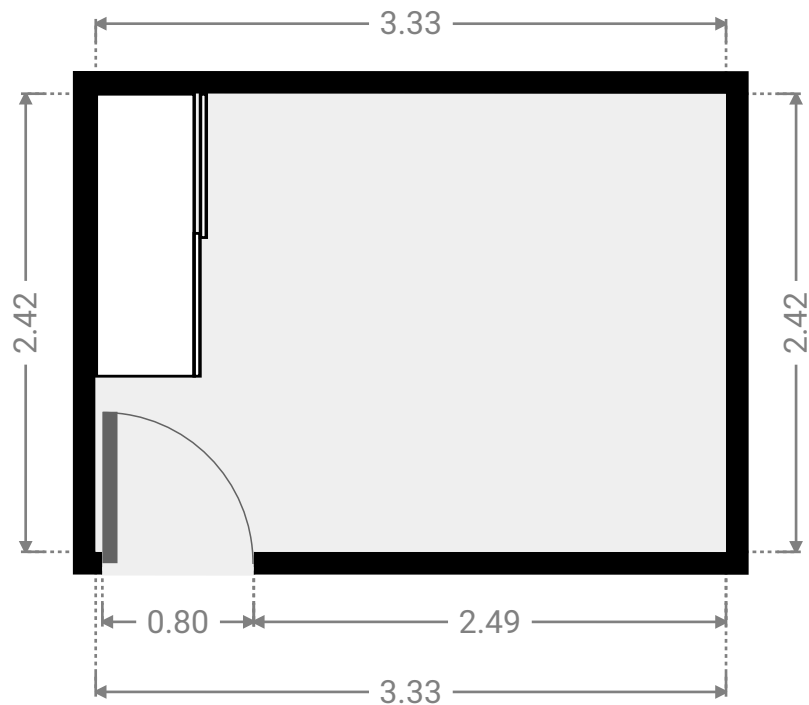
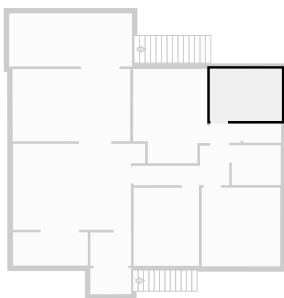

▼ **Bedroom**
1st Floor

WIDTH: 3.45 m • LENGTH: 4.37 m
AREA: 13.93 m² • PERIMETER: 15.63 m

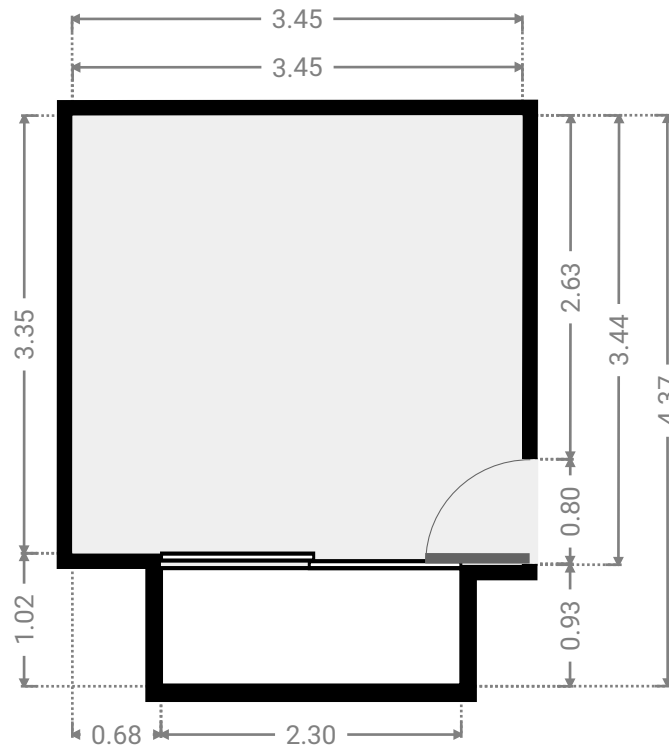
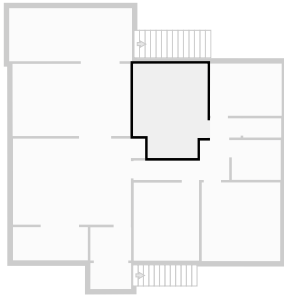

▼ **Other**
1st Floor

WIDTH: 5.70 m • LENGTH: 2.46 m
AREA: 14.02 m² • PERIMETER: 16.32 m

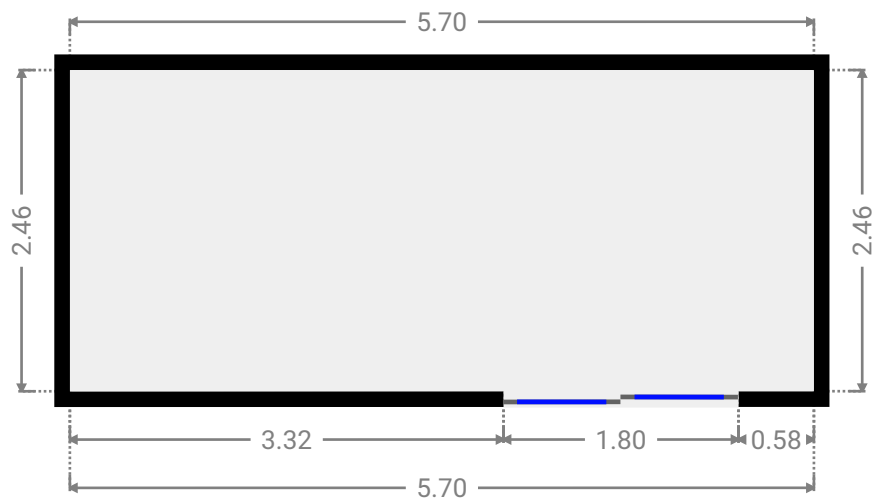
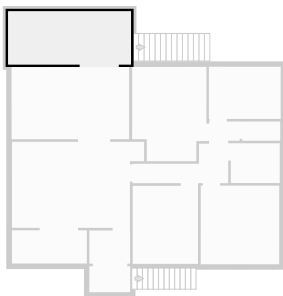

▼ Other
1st Floor

WIDTH: 1.89 m • LENGTH: 1.21 m
AREA: 2.28 m² • PERIMETER: 6.19 m

