

26 Archer street

SUBMITTED BY

Ray White Rockhampton Casey
stockers@cqoz.com

CREATED ON

2022-08-24

Floors

2

▼ Ground Floor

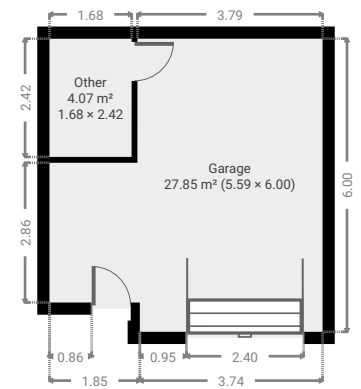
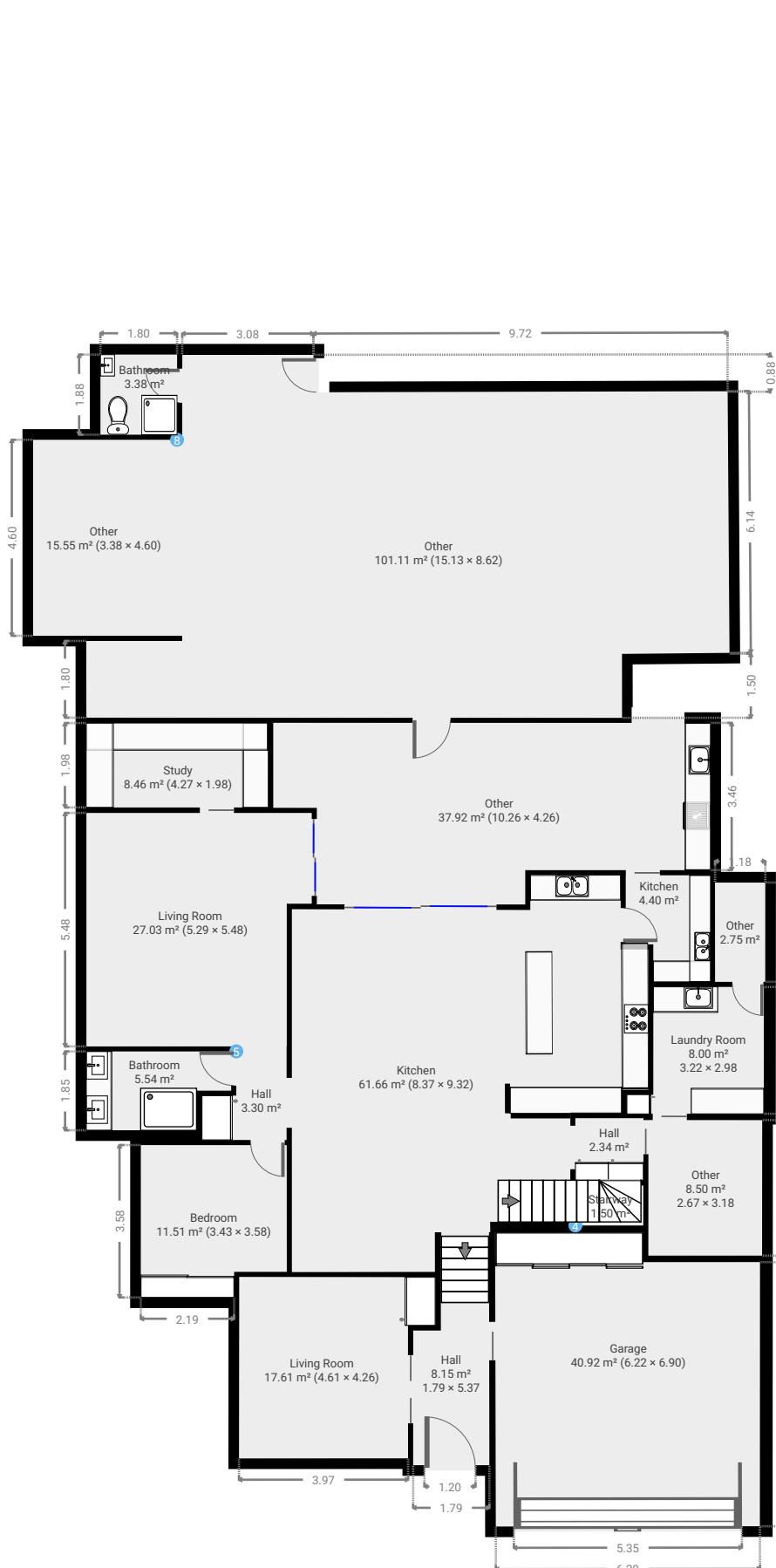

▼ **Bathroom**
Ground Floor

WIDTH: 3.40 m • LENGTH: 1.85 m
AREA: 5.54 m² • PERIMETER: 10.50 m

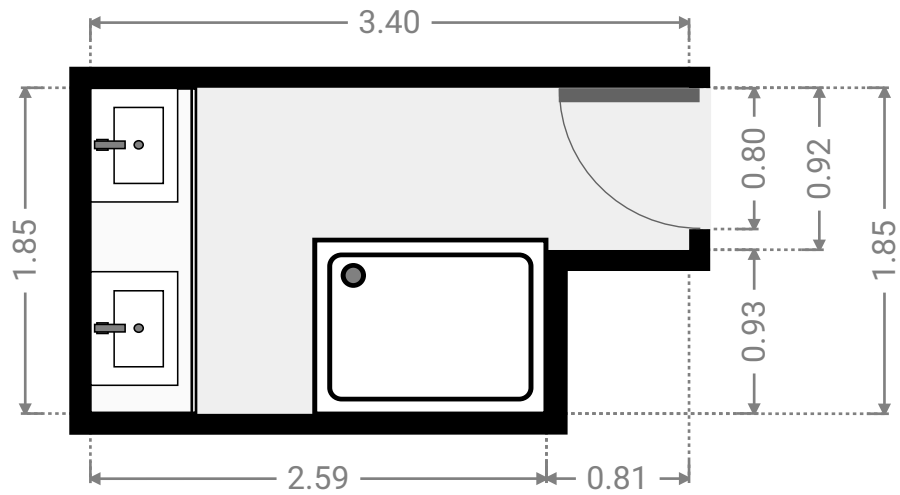
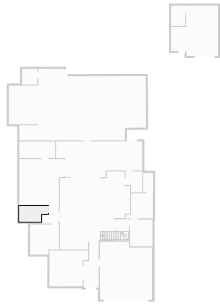

▼ **Bathroom**
Ground Floor

WIDTH: 1.80 m • LENGTH: 1.88 m
AREA: 3.38 m² • PERIMETER: 7.36 m

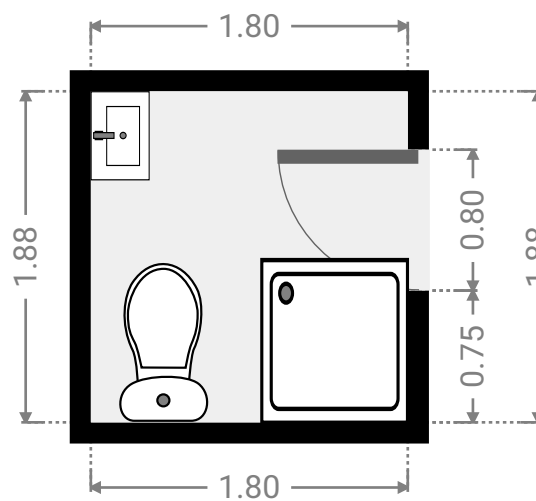
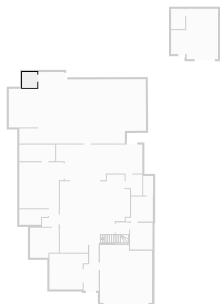

▼ **Bedroom**
Ground Floor

WIDTH: 3.43 m • LENGTH: 3.58 m
AREA: 11.51 m² • PERIMETER: 14.00 m

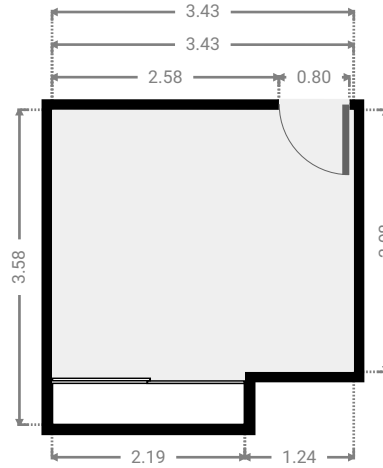
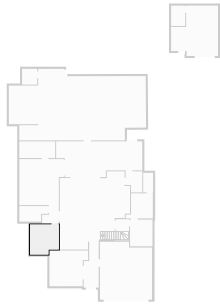

▼ **Garage**
Ground Floor

WIDTH: 6.22 m • LENGTH: 6.90 m
AREA: 40.92 m² • PERIMETER: 26.21 m

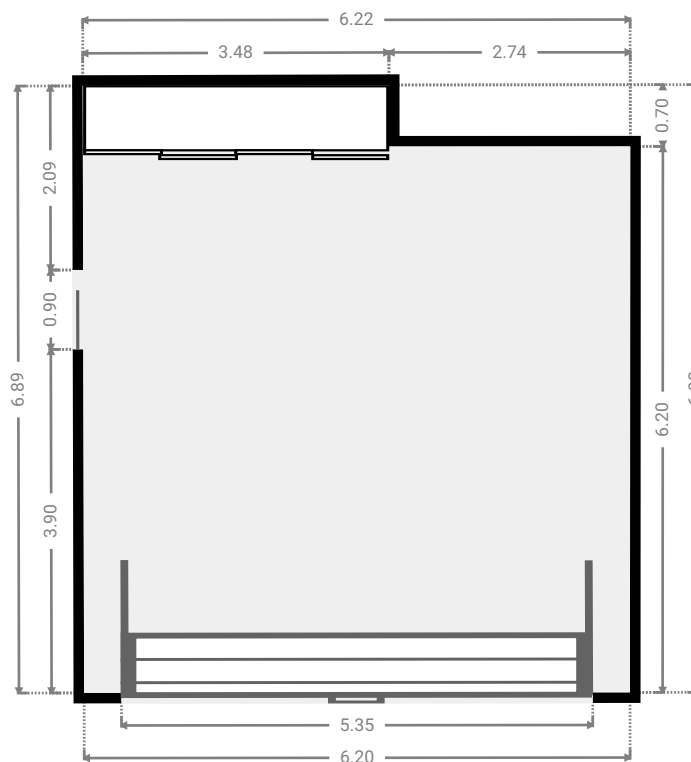
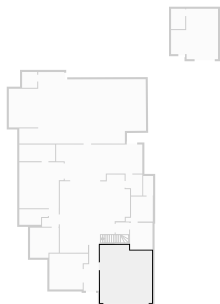

FLOORS: 2

▼ **Garage**
Ground Floor

WIDTH: 5.59 m • LENGTH: 6.00 m
AREA: 27.85 m² • PERIMETER: 23.18 m

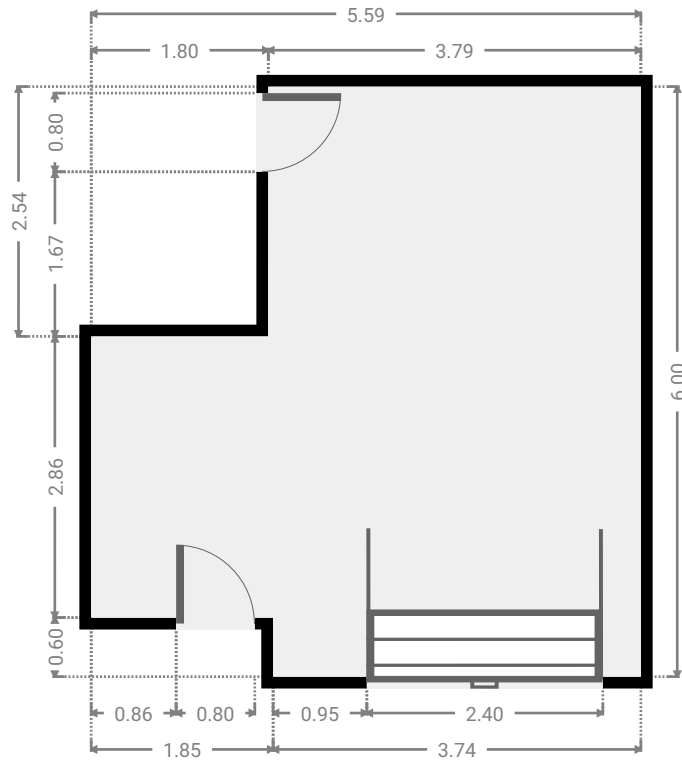
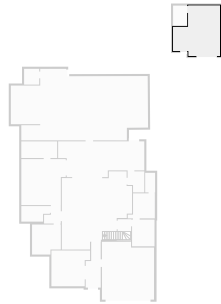

▼ **Hall**
Ground Floor

WIDTH: 1.79 m • LENGTH: 5.37 m
AREA: 8.15 m² • PERIMETER: 14.32 m

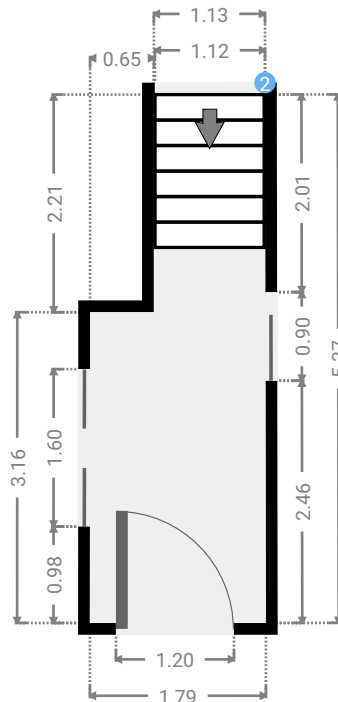

FLOORS: 2

▼ Hall
Ground Floor

WIDTH: 1.60 m • LENGTH: 1.46 m
AREA: 2.34 m² • PERIMETER: 6.12 m

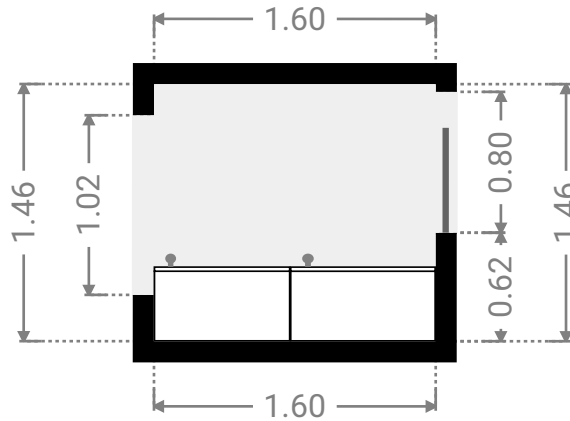
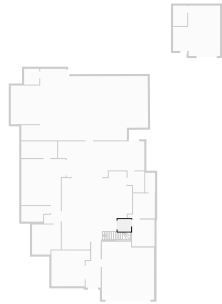

▼ Hall
Ground Floor

WIDTH: 1.99 m • LENGTH: 2.08 m
AREA: 3.30 m² • PERIMETER: 8.14 m

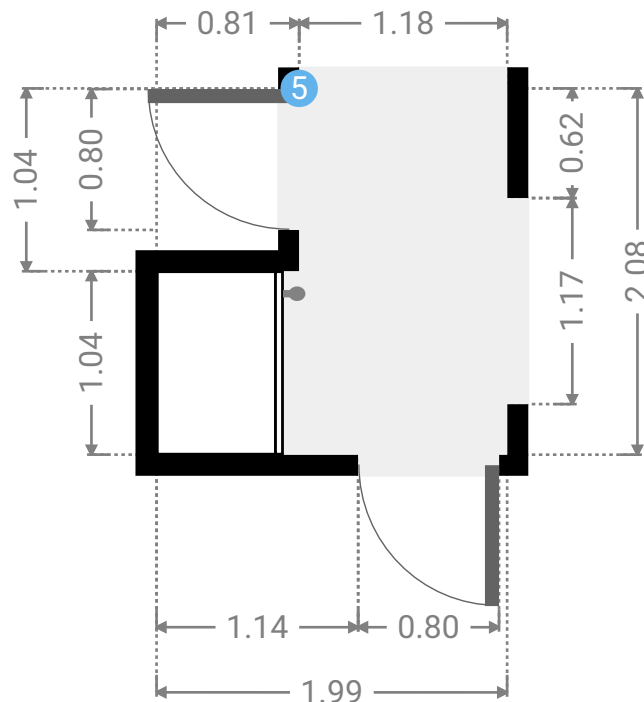
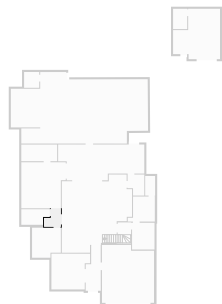

▼ **Hall/Ground Floor**

5 **OPENING**

Height
0.00 m



▼ Kitchen
Ground Floor

WIDTH: 8.37 m • LENGTH: 9.32 m
AREA: 61.66 m² • PERIMETER: 35.38 m

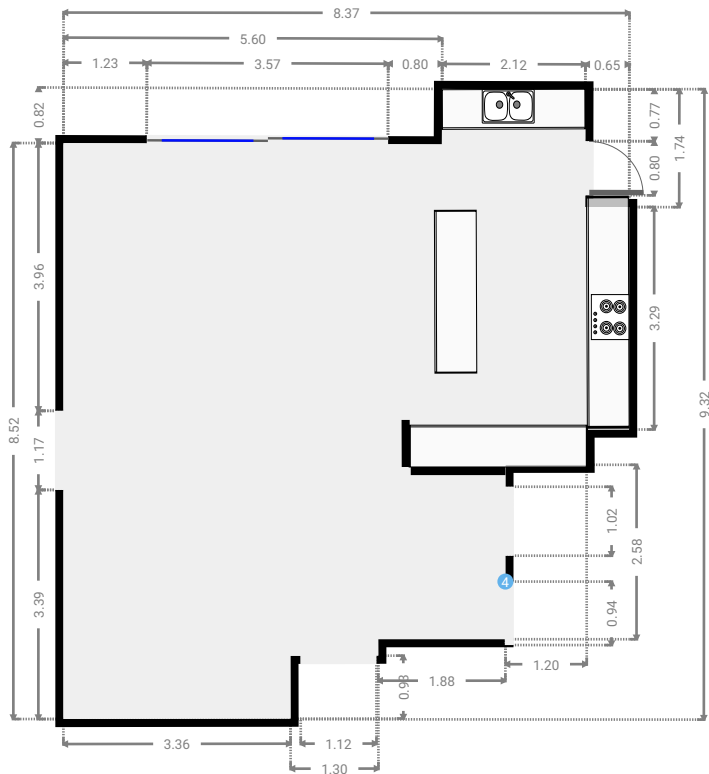
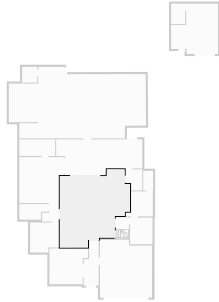

▼ Kitchen
Ground Floor

WIDTH: 1.99 m • LENGTH: 2.50 m
AREA: 4.40 m² • PERIMETER: 8.97 m

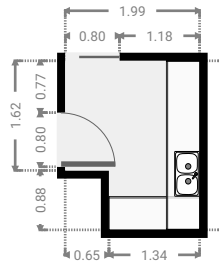
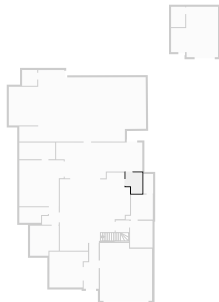

▼ **Laundry Room**
Ground Floor

WIDTH: 3.22 m • LENGTH: 2.98 m
AREA: 8.00 m² • PERIMETER: 12.40 m

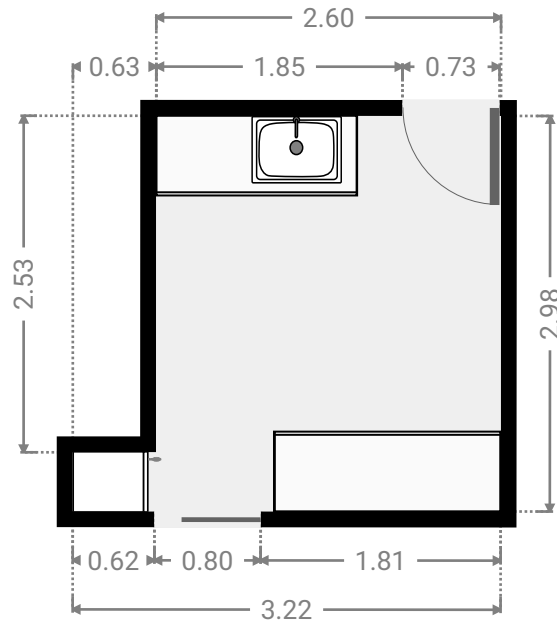
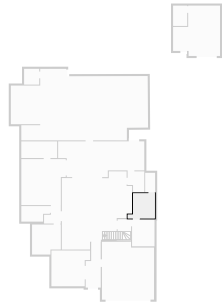

▼ **Living Room**
Ground Floor

WIDTH: 4.61 m • LENGTH: 4.26 m
AREA: 17.61 m² • PERIMETER: 17.73 m

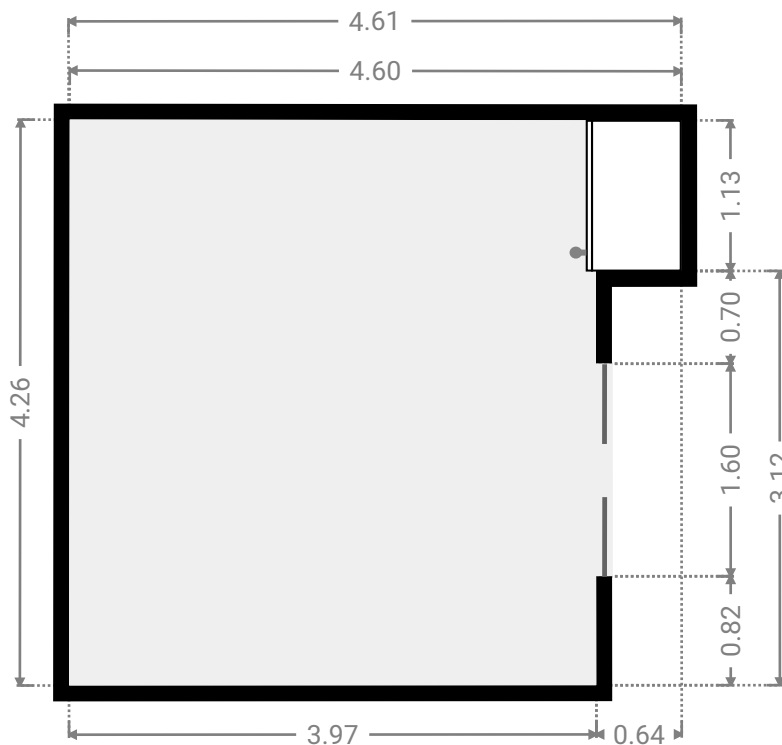
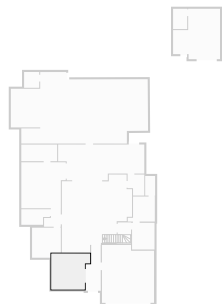

FLOORS: 2

▼ Living Room
Ground Floor

WIDTH: 5.29 m • LENGTH: 5.48 m
AREA: 27.03 m² • PERIMETER: 21.54 m

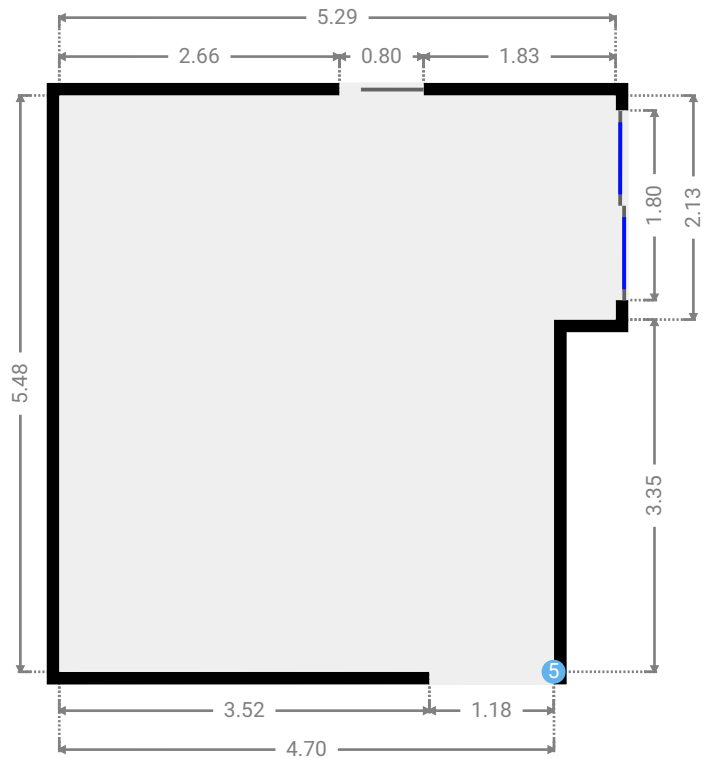
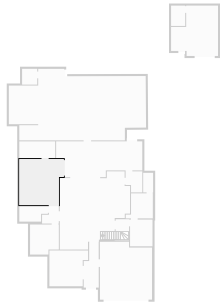

▼ Other
Ground Floor

WIDTH: 2.67 m • LENGTH: 3.18 m
AREA: 8.50 m² • PERIMETER: 11.70 m

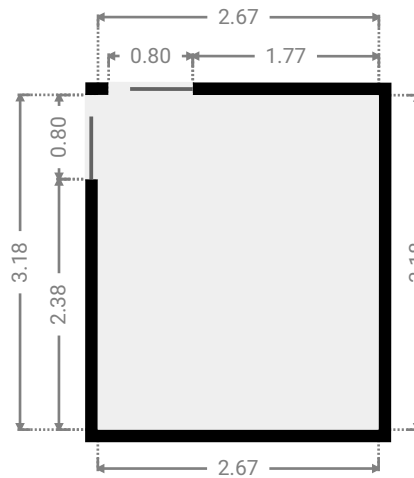

▼ Other
Ground Floor

WIDTH: 10.26 m • LENGTH: 4.26 m
AREA: 37.92 m² • PERIMETER: 29.05 m

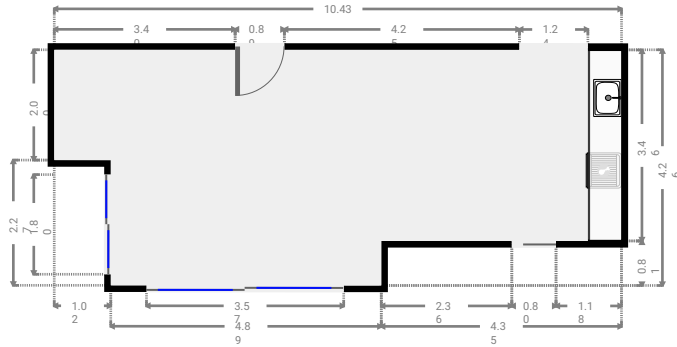
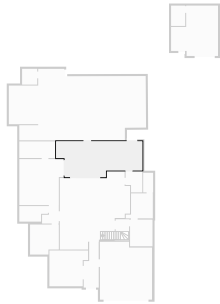

▼ Other
Ground Floor

WIDTH: 15.13 m • LENGTH: 8.62 m
AREA: 101.11 m² • PERIMETER: 47.19 m

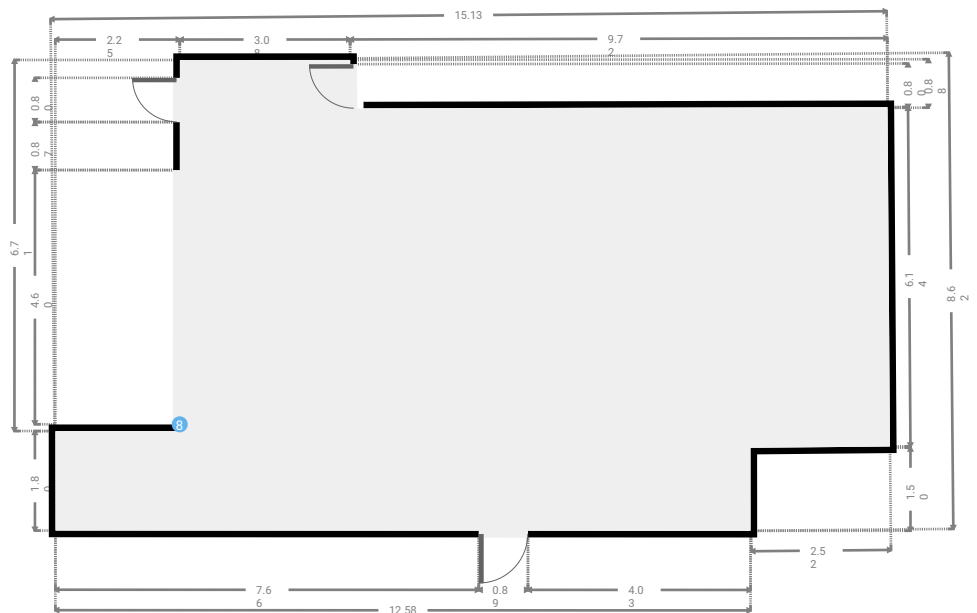
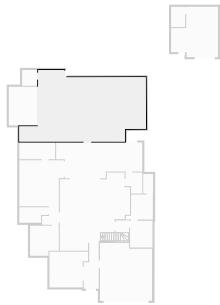

▼ Other
Ground Floor

WIDTH: 3.38 m • LENGTH: 4.60 m
AREA: 15.55 m² • PERIMETER: 15.96 m

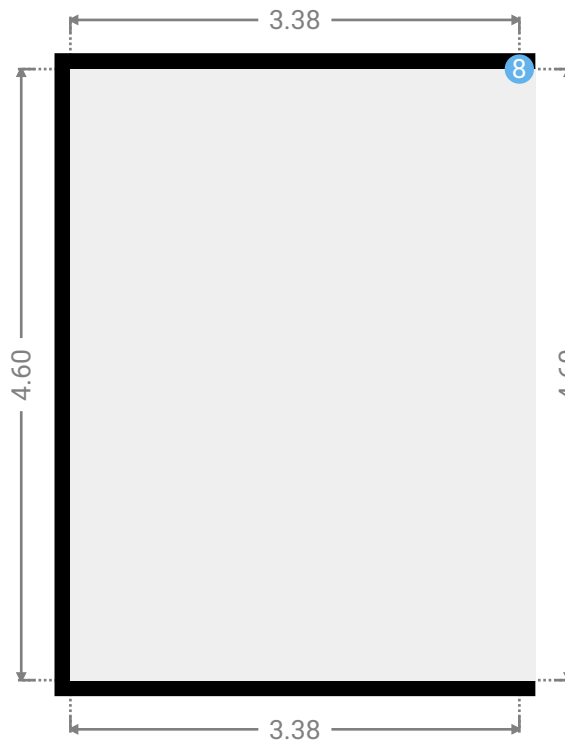
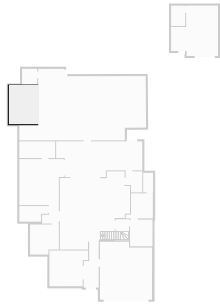

▼ Other/Ground Floor

8 OPENING

Height
0.00 m



▼ Other
Ground Floor

WIDTH: 1.68 m • LENGTH: 2.42 m
AREA: 4.07 m² • PERIMETER: 8.20 m

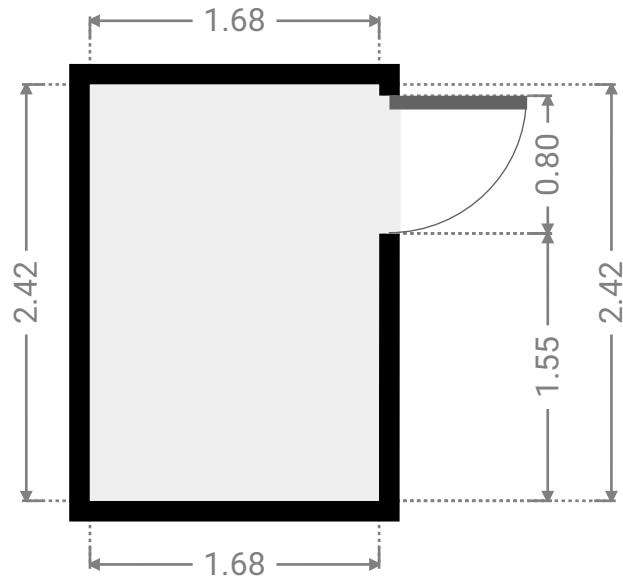
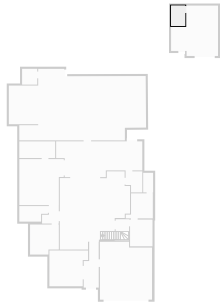

▼ Other
Ground Floor

WIDTH: 1.18 m • LENGTH: 2.33 m
AREA: 2.75 m² • PERIMETER: 7.02 m

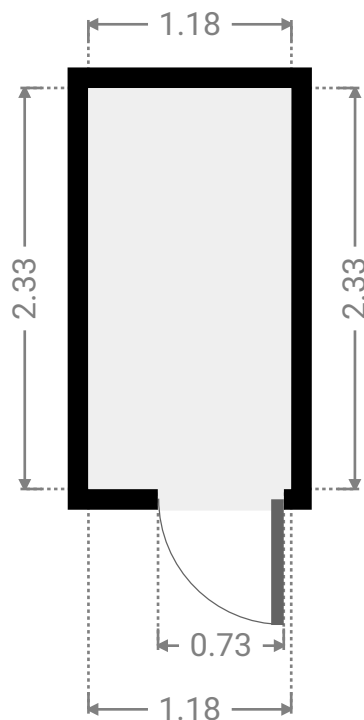
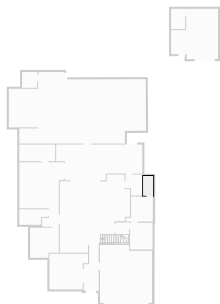

▼ **Stairway**
Ground Floor

WIDTH: 1.59 m • LENGTH: 0.94 m
AREA: 1.50 m² • PERIMETER: 5.06 m

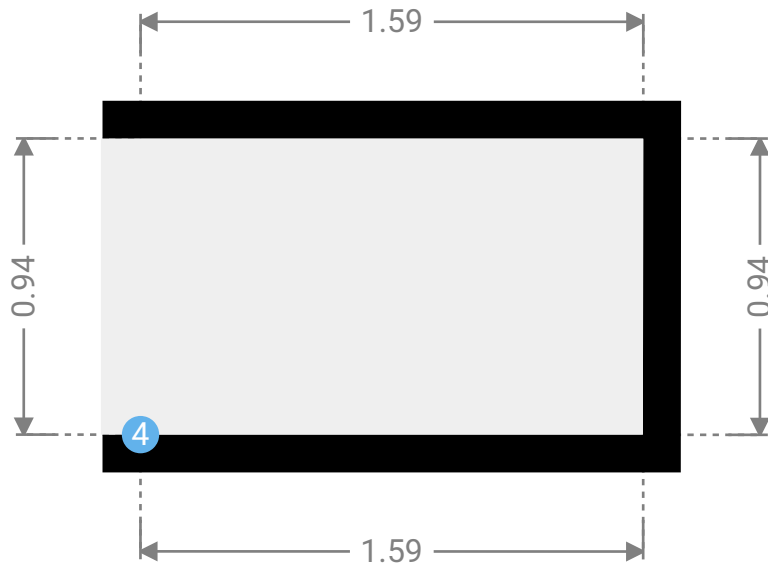
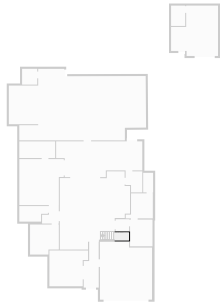

▼ **Stairway/Ground Floor**

4 OPENING

Height
0.00 m



▼ **Study**
Ground Floor

WIDTH: 4.27 m • LENGTH: 1.98 m
AREA: 8.46 m² • PERIMETER: 12.50 m

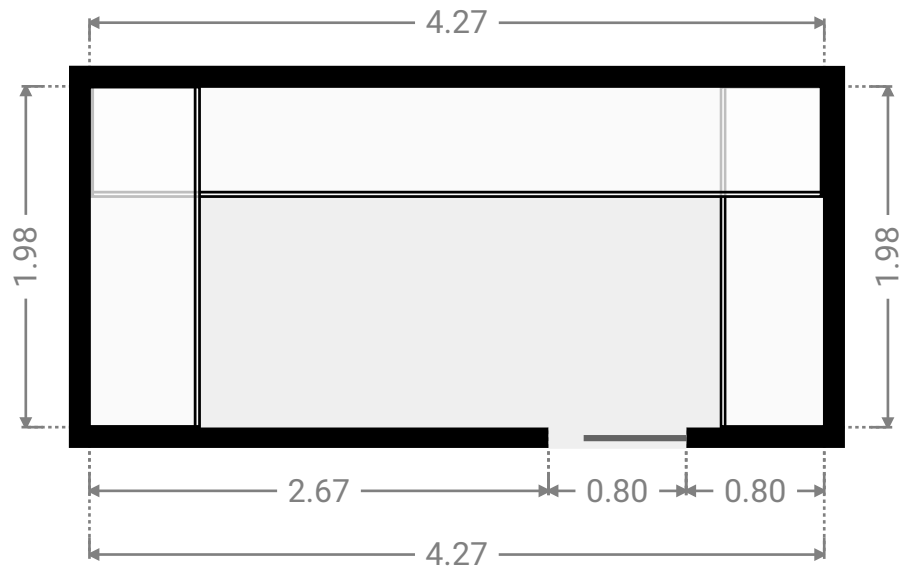
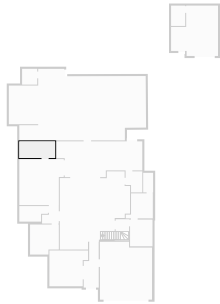

▼ 1st Floor

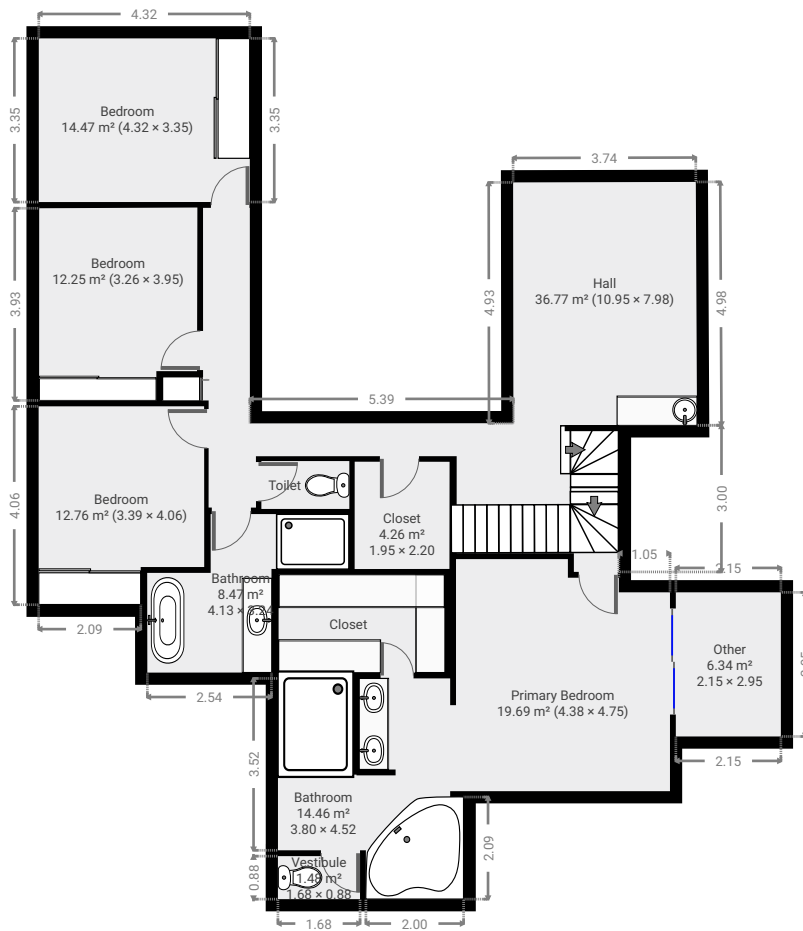

▼ Bathroom
1st Floor

WIDTH: 4.13 m • LENGTH: 3.24 m
AREA: 8.47 m² • PERIMETER: 14.75 m

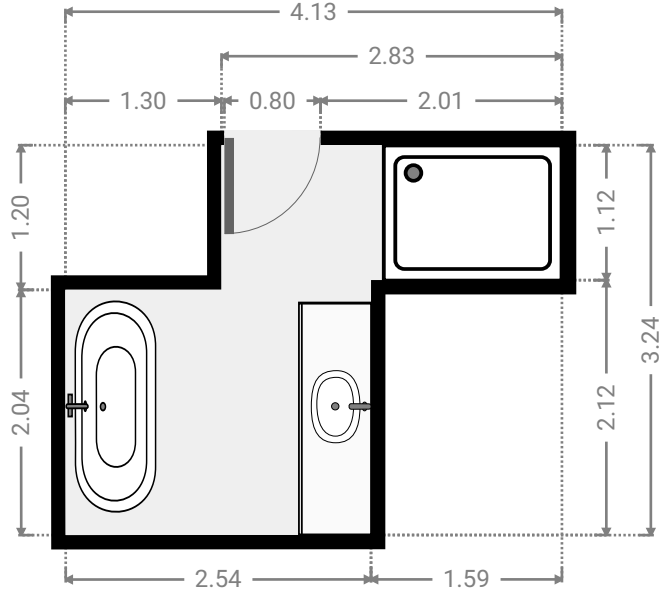
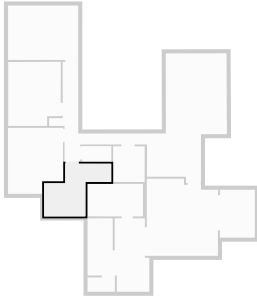

▼ Bathroom
1st Floor

WIDTH: 3.80 m • LENGTH: 4.52 m
AREA: 14.46 m² • PERIMETER: 20.58 m

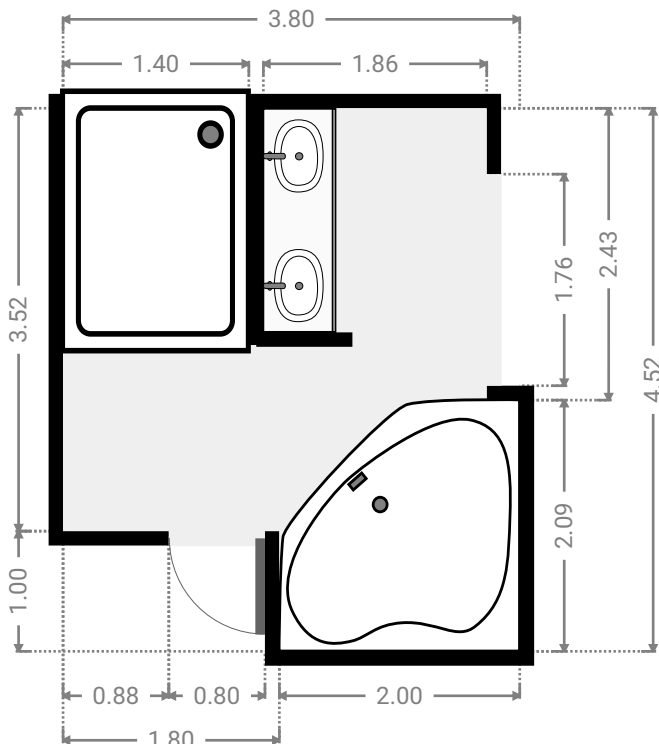
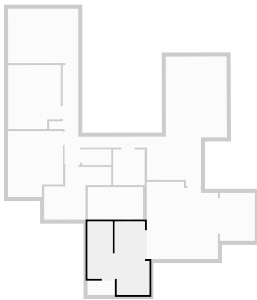

▼ **Bedroom**
1st Floor

WIDTH: 4.32 m • LENGTH: 3.35 m
AREA: 14.47 m² • PERIMETER: 15.34 m

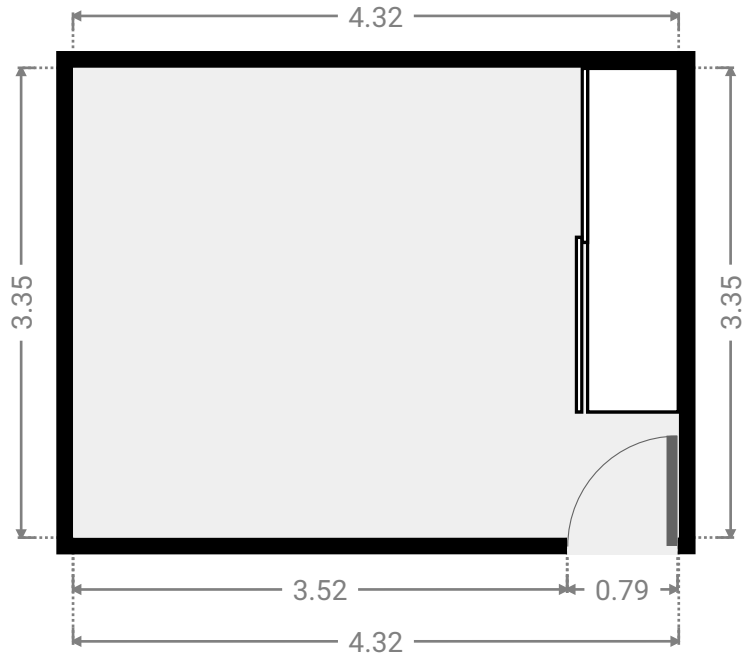
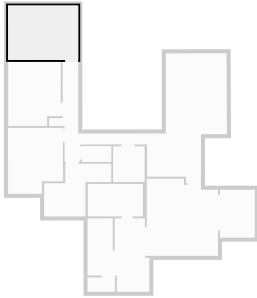

▼ **Bedroom**
1st Floor

WIDTH: 3.26 m • LENGTH: 3.95 m
AREA: 12.25 m² • PERIMETER: 14.36 m

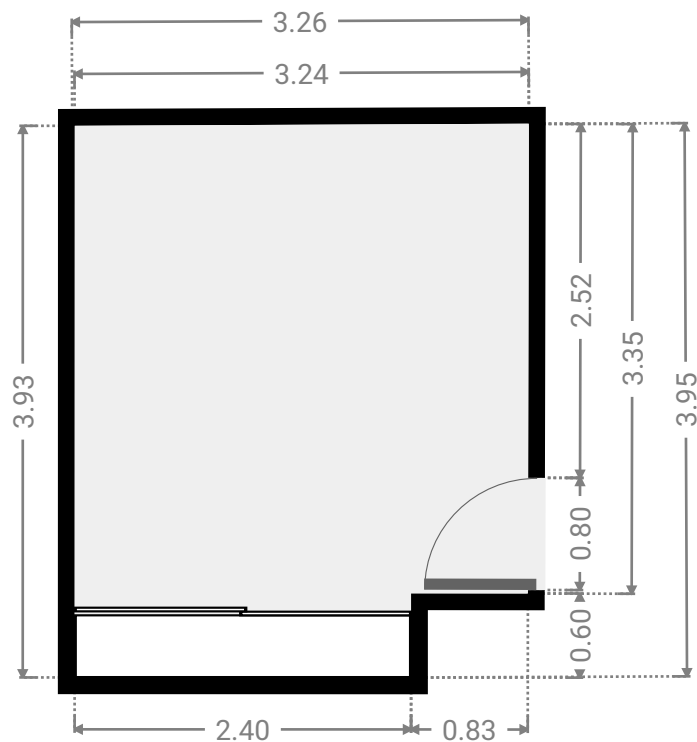
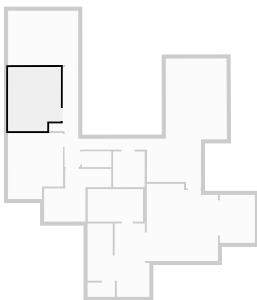

▼ **Bedroom**
1st Floor

WIDTH: 3.39 m • LENGTH: 4.06 m
AREA: 12.76 m² • PERIMETER: 14.90 m

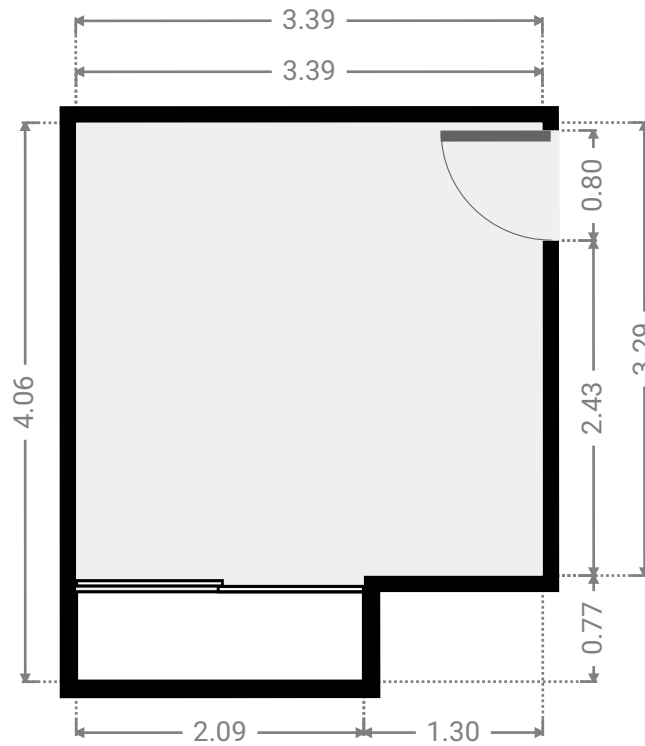
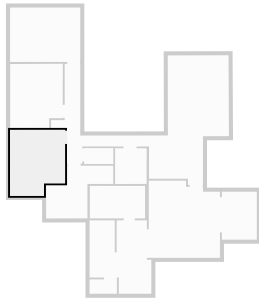

▼ **Closet**
1st Floor

WIDTH: 3.40 m • LENGTH: 2.00 m
AREA: 6.80 m² • PERIMETER: 10.80 m

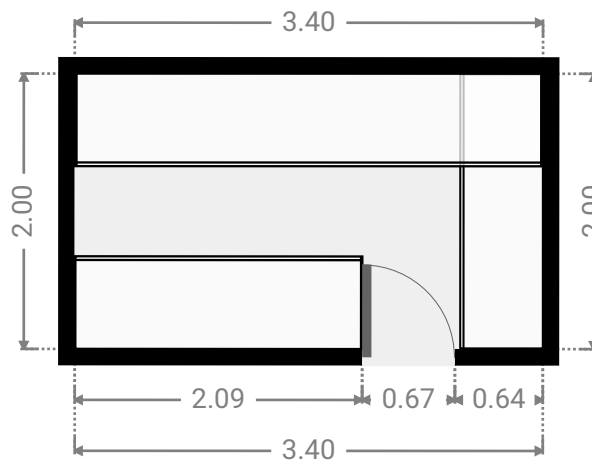
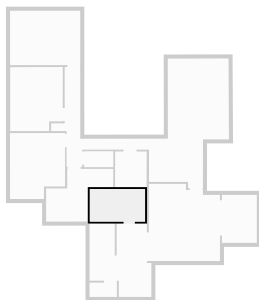

▼ Hall
1st Floor

WIDTH: 10.95 m • LENGTH: 7.98 m
AREA: 36.77 m² • PERIMETER: 48.75 m

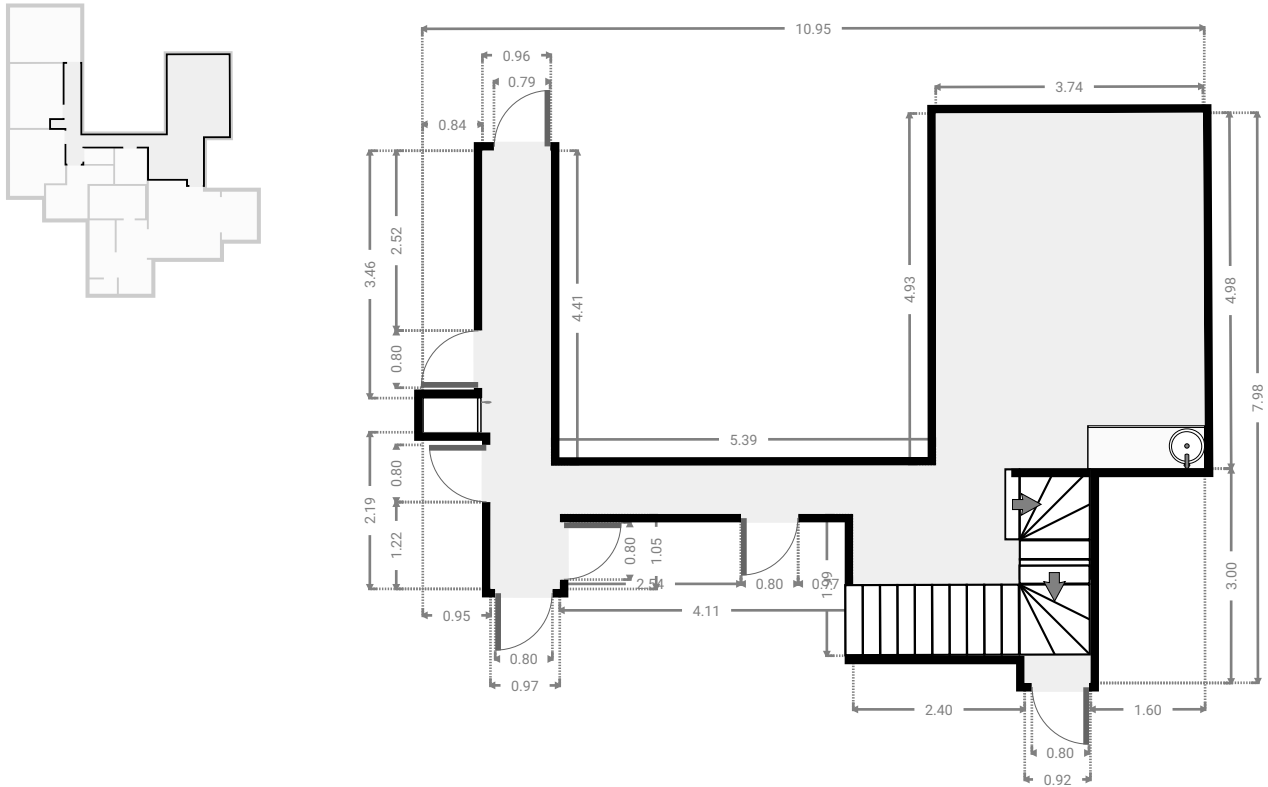

▼ Closet
1st Floor

WIDTH: 1.95 m • LENGTH: 2.20 m
AREA: 4.26 m² • PERIMETER: 8.27 m

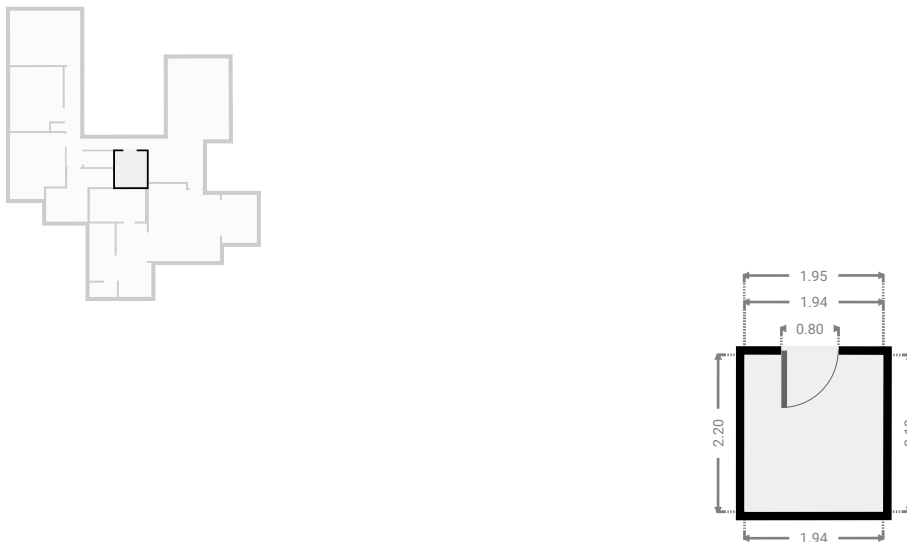

▼ Other
1st Floor

WIDTH: 2.15 m • LENGTH: 2.95 m
AREA: 6.34 m² • PERIMETER: 10.20 m

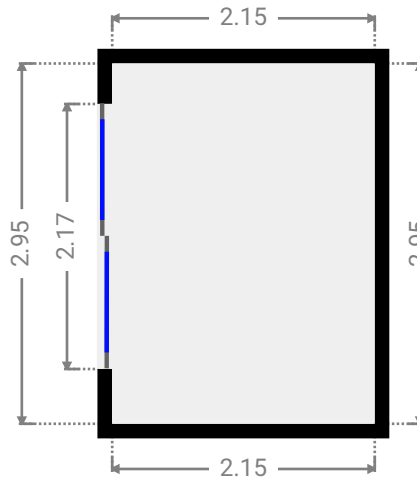
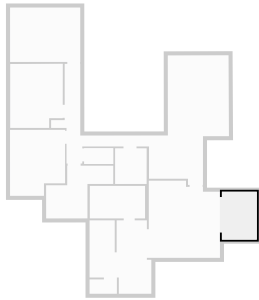

▼ Primary Bedroom
1st Floor

WIDTH: 4.38 m • LENGTH: 4.75 m
AREA: 19.69 m² • PERIMETER: 18.26 m

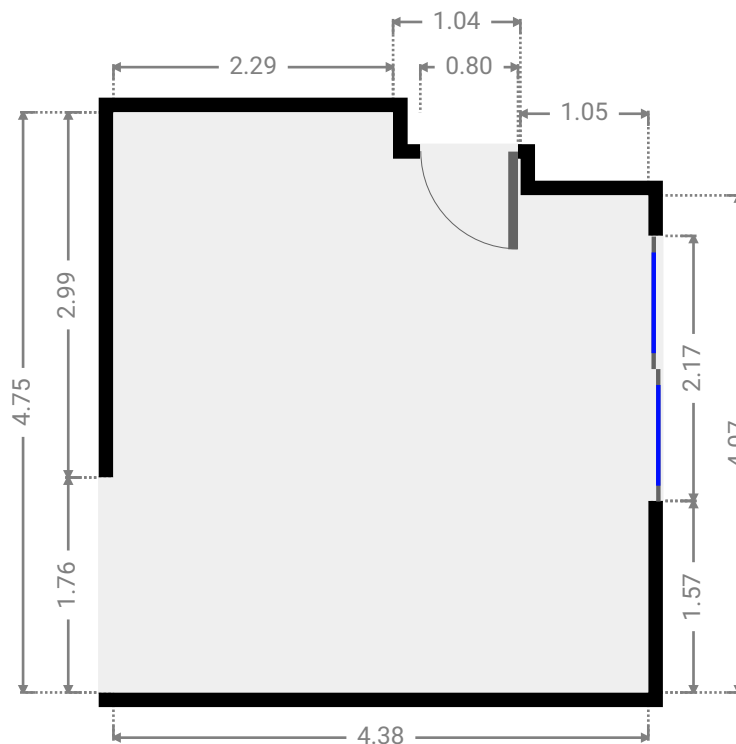
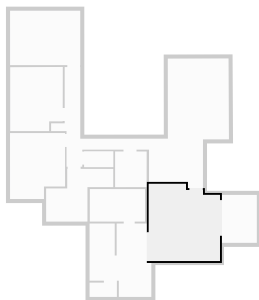

FLOORS: 2

▼ Toilet
1st Floor

WIDTH: 1.80 m • LENGTH: 0.98 m
AREA: 1.76 m² • PERIMETER: 5.56 m

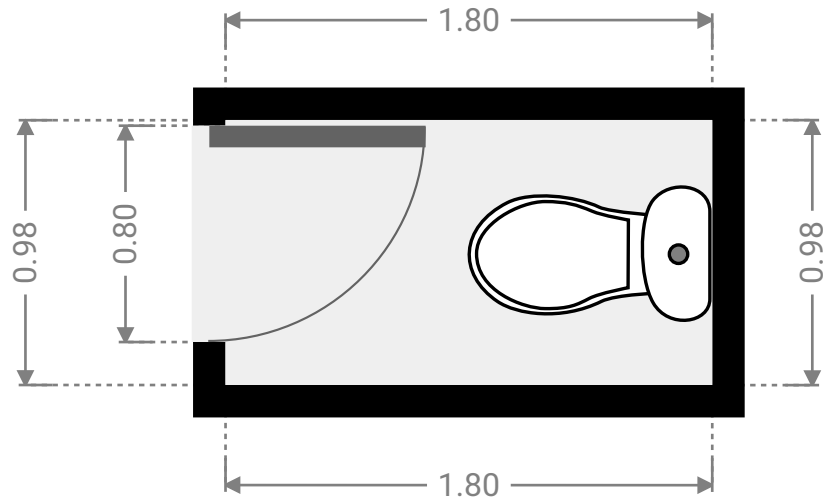
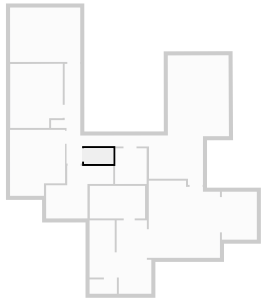

▼ Vestibule
1st Floor

WIDTH: 1.68 m • LENGTH: 0.88 m
AREA: 1.48 m² • PERIMETER: 5.12 m

