

258 Campbell Street

Created on
2021-10-05

Floors
2

▼ Ground Floor

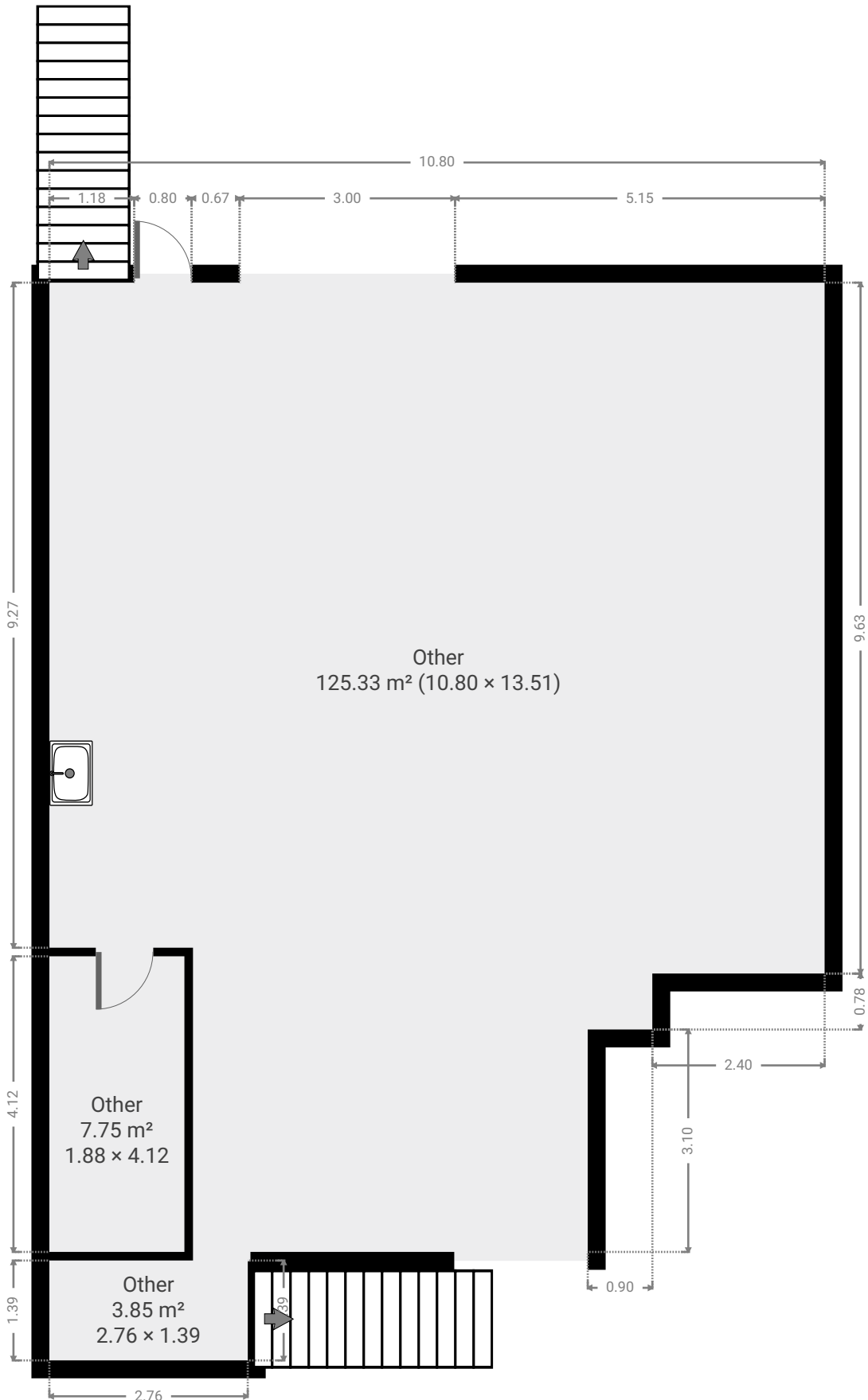

▼ Other
Ground Floor

WIDTH: 10.80 m • LENGTH: 13.51 m
AREA: 125.33 m² • PERIMETER: 48.62 m

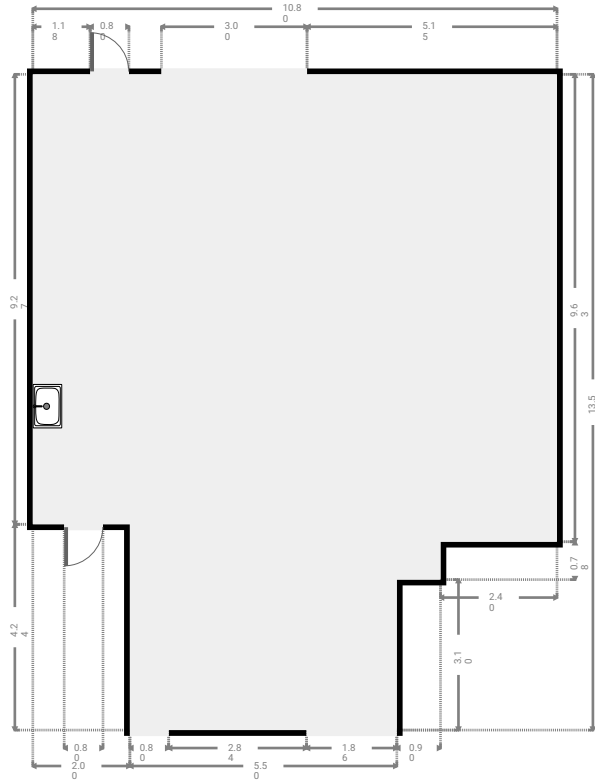
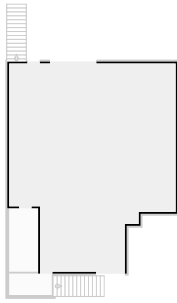

▼ Other
Ground Floor

WIDTH: 1.88 m • LENGTH: 4.12 m
AREA: 7.75 m² • PERIMETER: 12.00 m

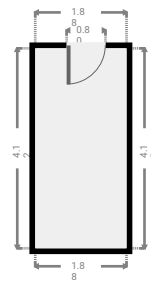
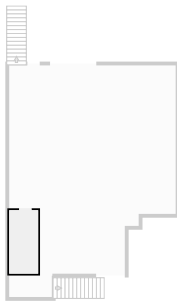

▼ Other
Ground Floor

WIDTH: 2.76 m • LENGTH: 1.39 m
AREA: 3.85 m² • PERIMETER: 8.31 m

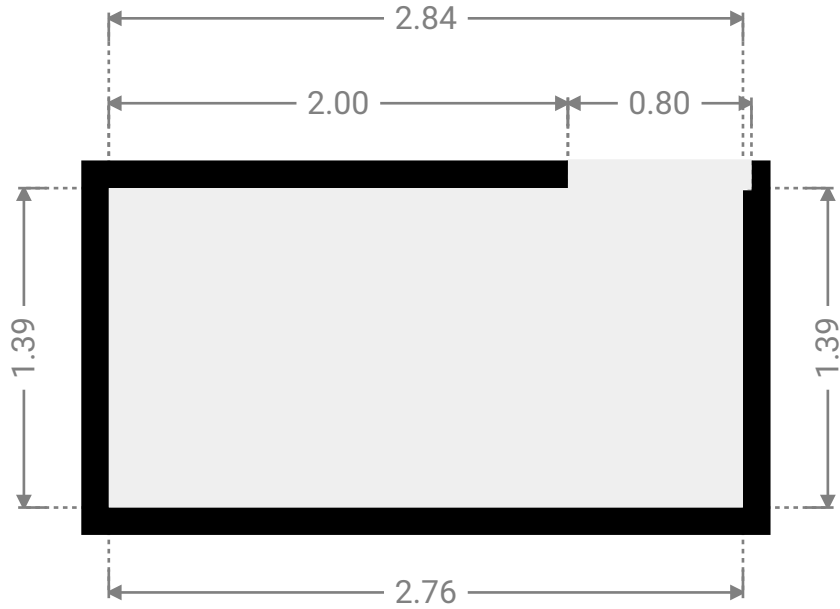
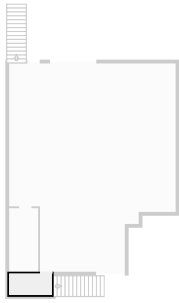

▼ 1st Floor



▼ **Bedroom**
1st Floor

WIDTH: 3.35 m • LENGTH: 4.24 m
AREA: 14.20 m² • PERIMETER: 15.18 m

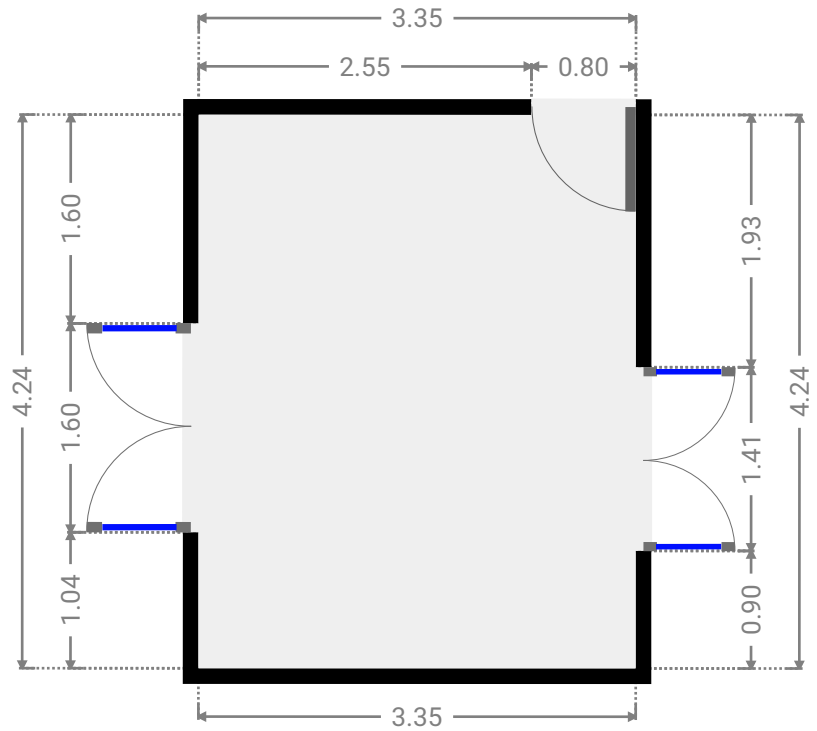
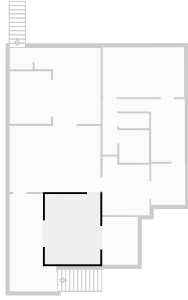

▼ **Closet**
1st Floor

WIDTH: 2.15 m • LENGTH: 2.90 m
AREA: 6.23 m² • PERIMETER: 10.10 m

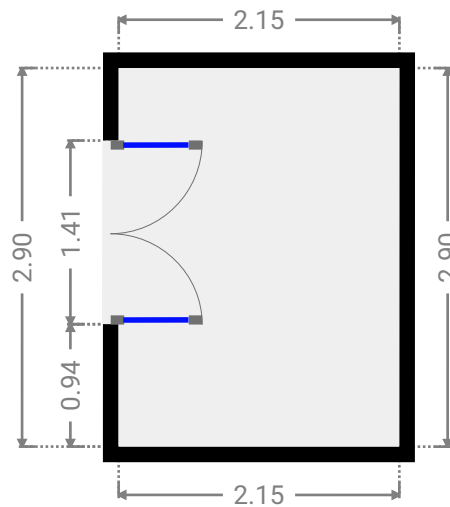
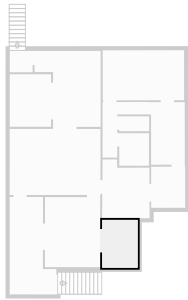

▼ Living Room
1st Floor

WIDTH: 5.50 m • LENGTH: 4.00 m
AREA: 22.01 m² • PERIMETER: 19.00 m

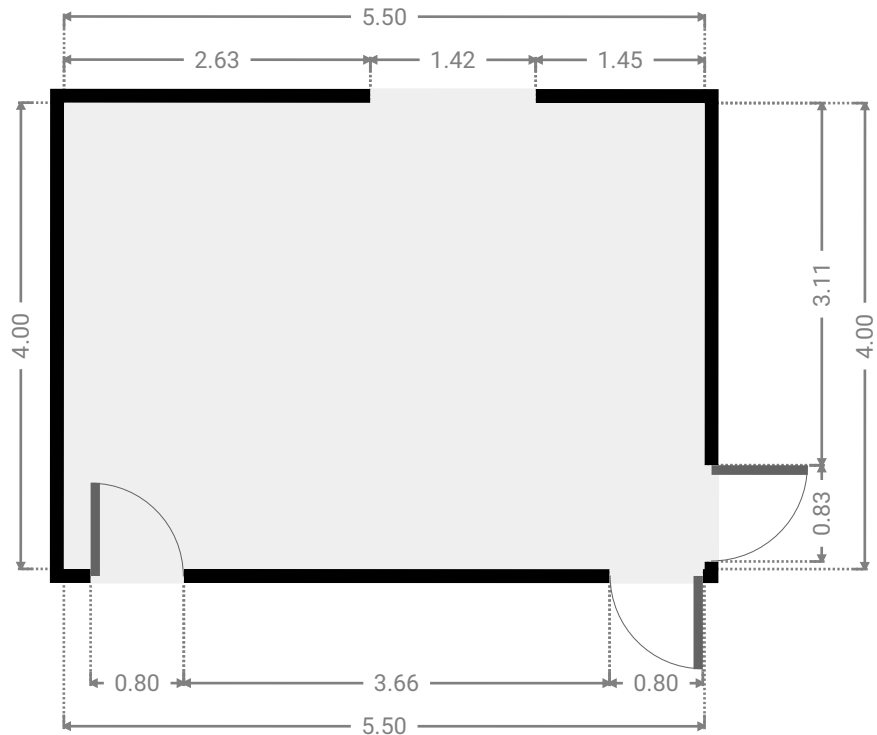
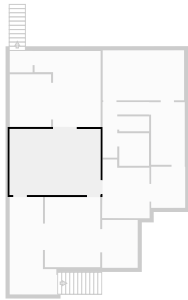

▼ Bedroom
1st Floor

WIDTH: 2.88 m • LENGTH: 3.56 m
AREA: 9.17 m² • PERIMETER: 12.82 m

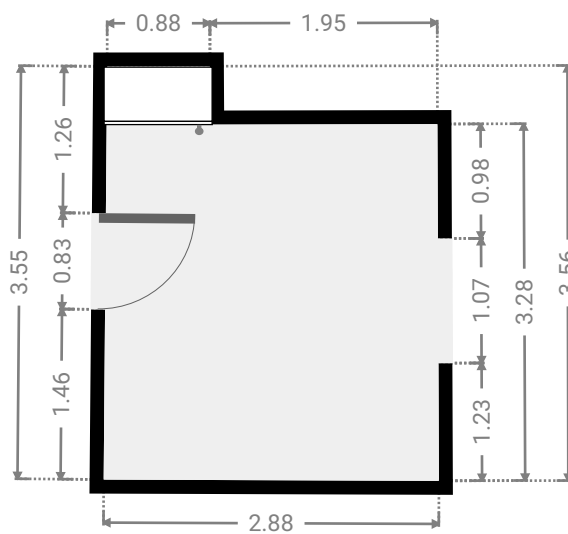
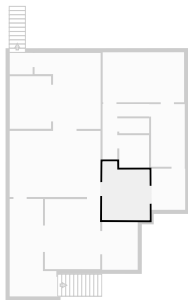

▼ **Closet**
1st Floor

WIDTH: 2.06 m • LENGTH: 2.49 m
AREA: 5.13 m² • PERIMETER: 9.10 m

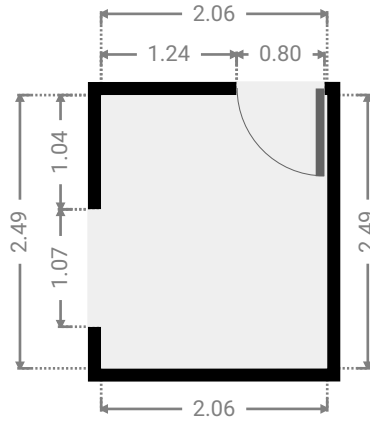
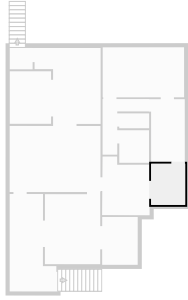

▼ **Bathroom**
1st Floor

WIDTH: 2.04 m • LENGTH: 3.79 m
AREA: 7.73 m² • PERIMETER: 11.66 m

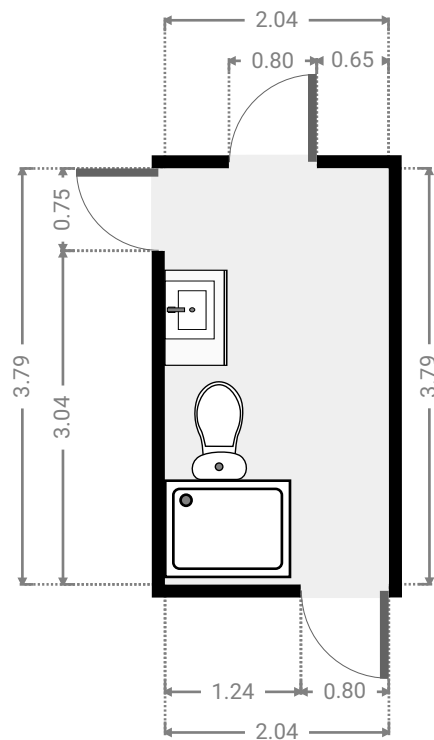
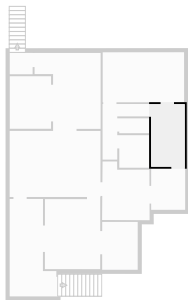

▼ **Bedroom**
1st Floor

WIDTH: 4.93 m • LENGTH: 3.03 m
AREA: 14.93 m² • PERIMETER: 15.92 m

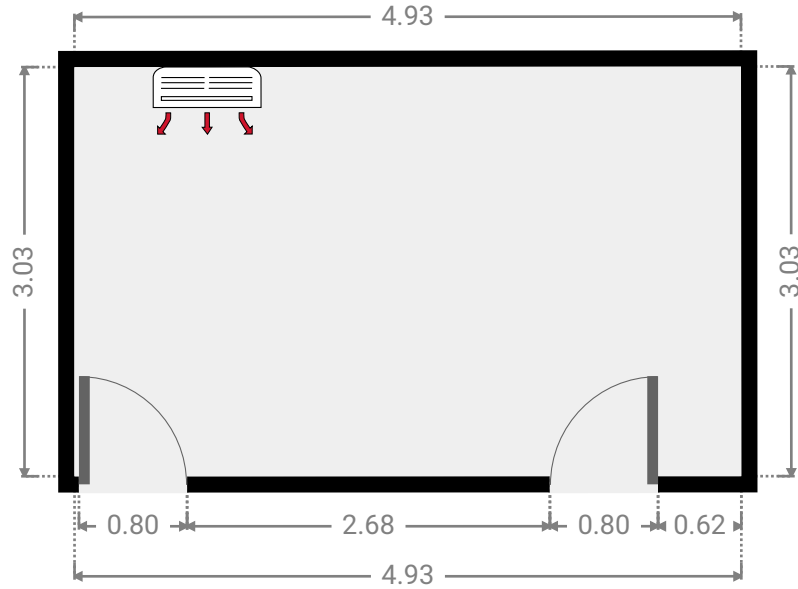
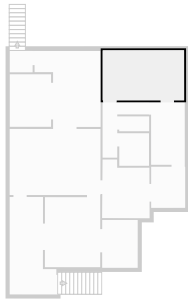

▼ **Hall**
1st Floor

WIDTH: 2.82 m • LENGTH: 3.37 m
AREA: 4.44 m² • PERIMETER: 12.38 m

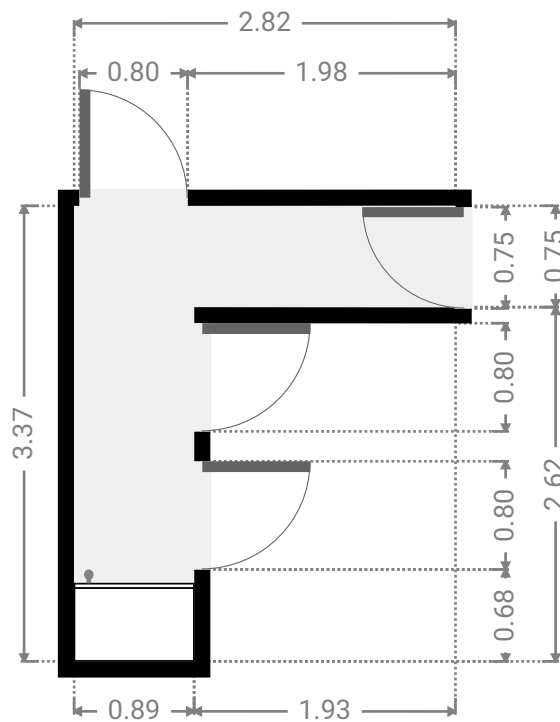
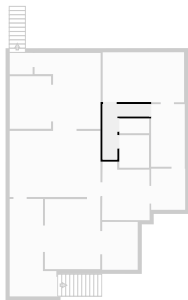

▼ Bathroom
1st Floor

WIDTH: 1.80 m • LENGTH: 1.97 m
AREA: 3.55 m² • PERIMETER: 7.54 m

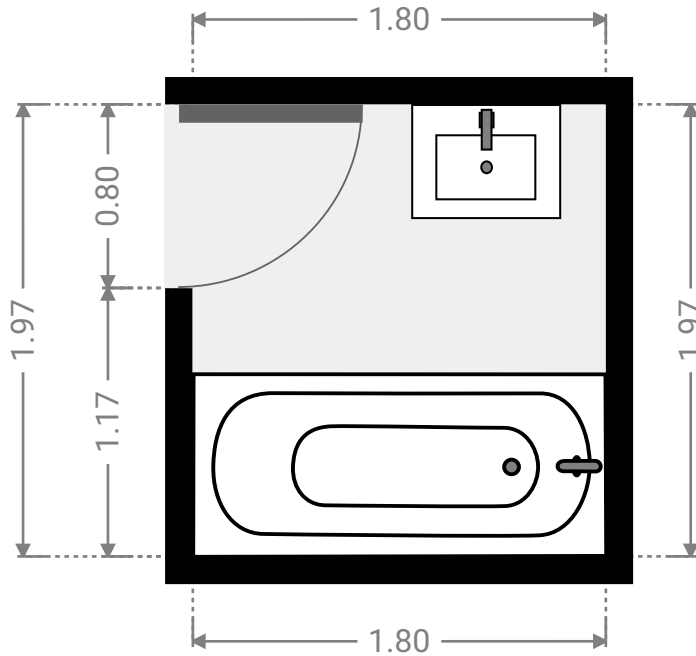
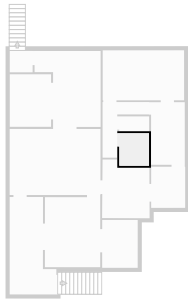

▼ Toilet
1st Floor

WIDTH: 1.81 m • LENGTH: 0.90 m
AREA: 1.63 m² • PERIMETER: 5.42 m

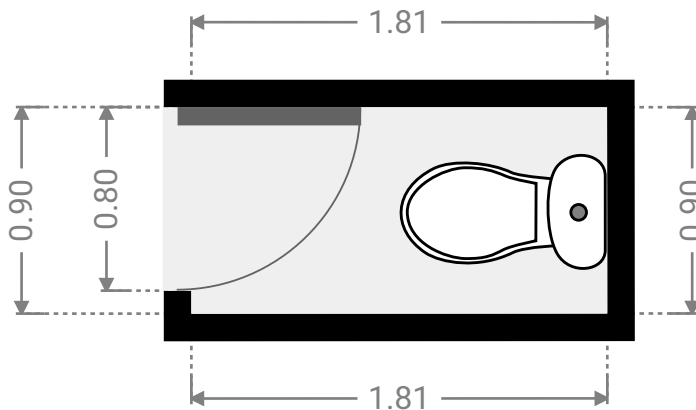
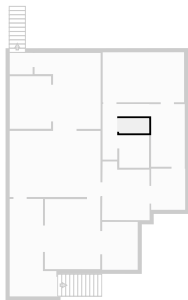

▼ **Dining Room**
1st Floor

WIDTH: 4.00 m • LENGTH: 4.60 m
AREA: 14.68 m² • PERIMETER: 17.20 m

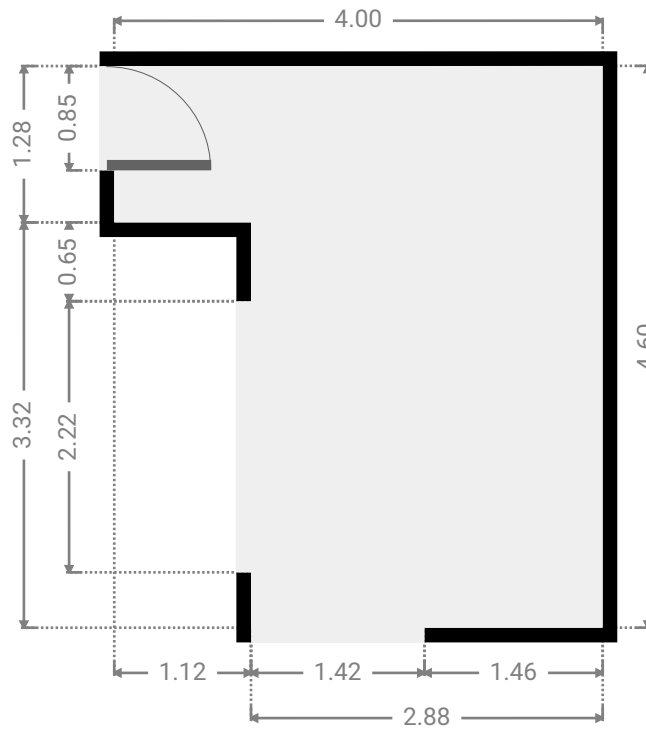
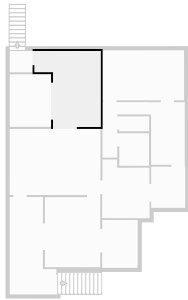

▼ **Kitchen**
1st Floor

WIDTH: 2.50 m • LENGTH: 3.18 m
AREA: 7.95 m² • PERIMETER: 11.36 m

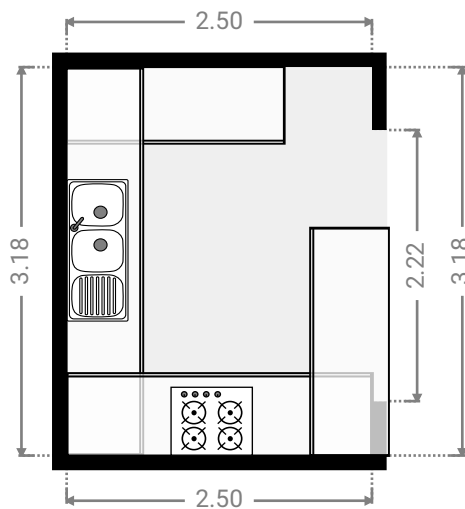
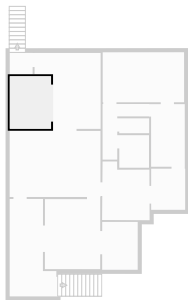

▼ Other
1st Floor

WIDTH: 1.38 m • LENGTH: 1.29 m
AREA: 1.79 m² • PERIMETER: 5.35 m

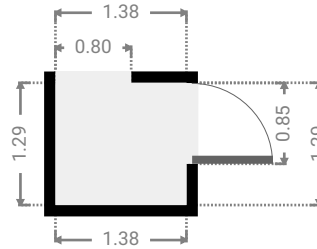
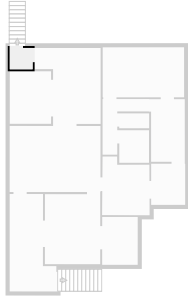

▼ Other
1st Floor

WIDTH: 2.83 m • LENGTH: 5.90 m
AREA: 13.14 m² • PERIMETER: 17.47 m

