

255 Diplock Street

Created on
2021-09-23

Floors
2

▼ Ground Floor

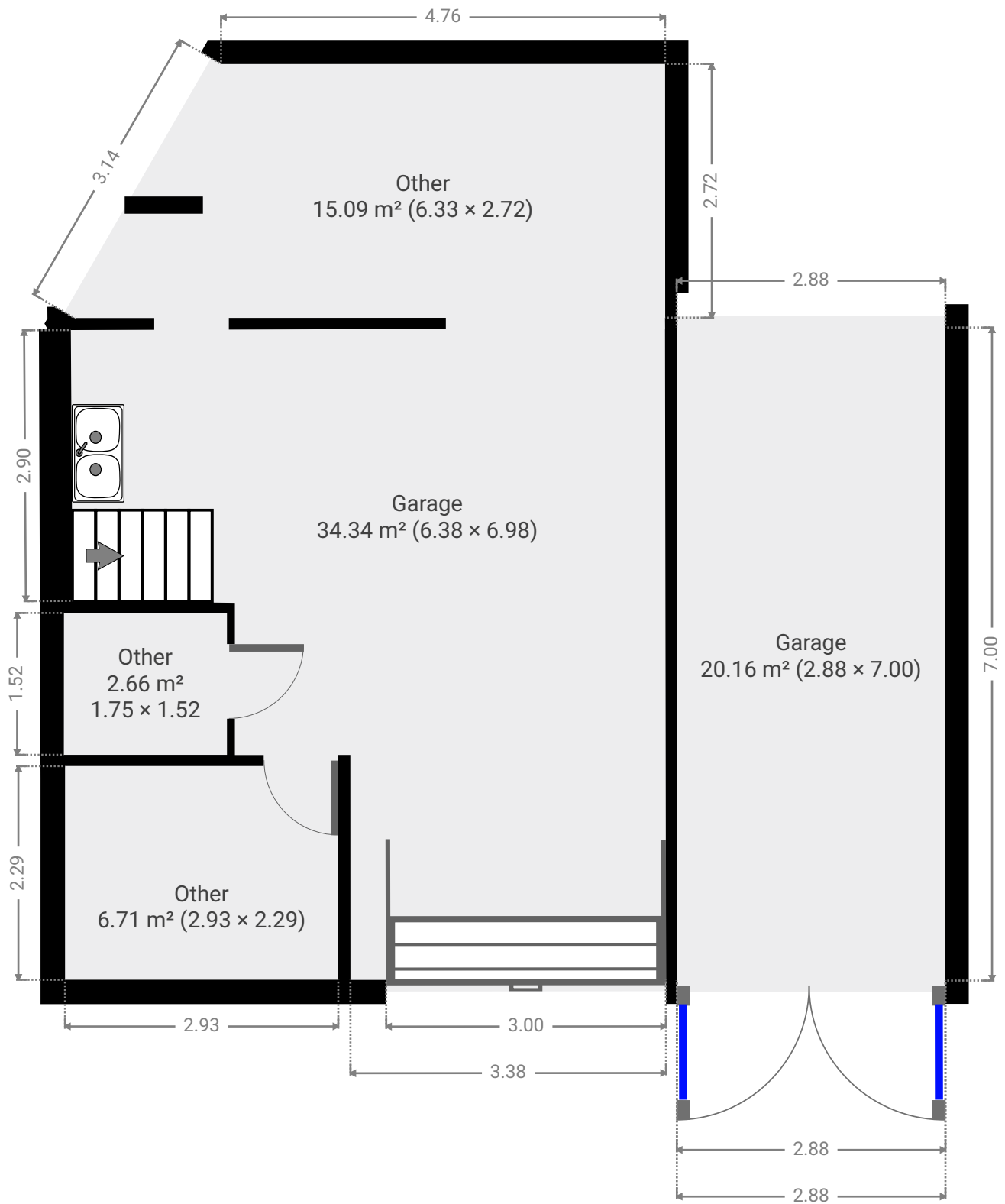

▼ **Garage**
Ground Floor

WIDTH: 6.38 m • LENGTH: 6.98 m
AREA: 34.34 m² • PERIMETER: 26.66 m

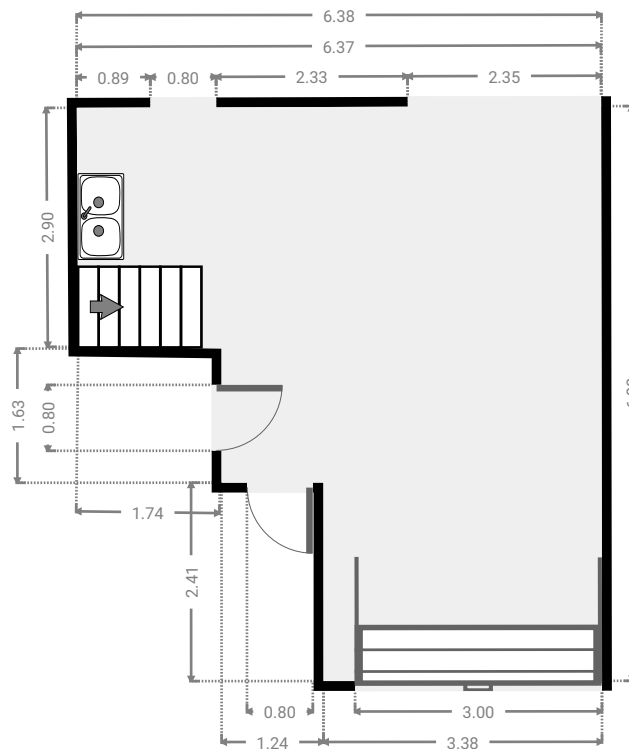
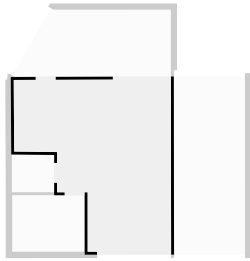

▼ **Other**
Ground Floor

WIDTH: 2.93 m • LENGTH: 2.29 m
AREA: 6.71 m² • PERIMETER: 10.44 m

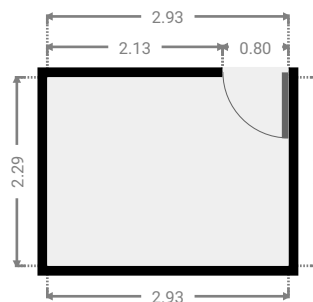
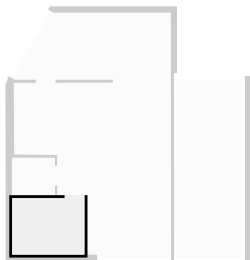

▼ Other
Ground Floor

WIDTH: 1.75 m • LENGTH: 1.52 m
AREA: 2.66 m² • PERIMETER: 6.54 m

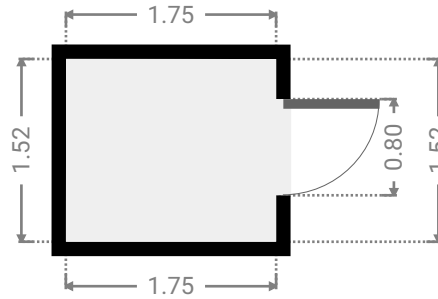
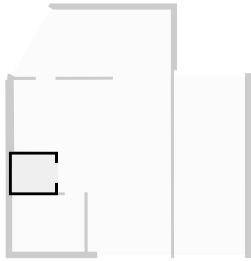

▼ Other
Ground Floor

WIDTH: 6.33 m • LENGTH: 2.72 m
AREA: 15.09 m² • PERIMETER: 16.96 m

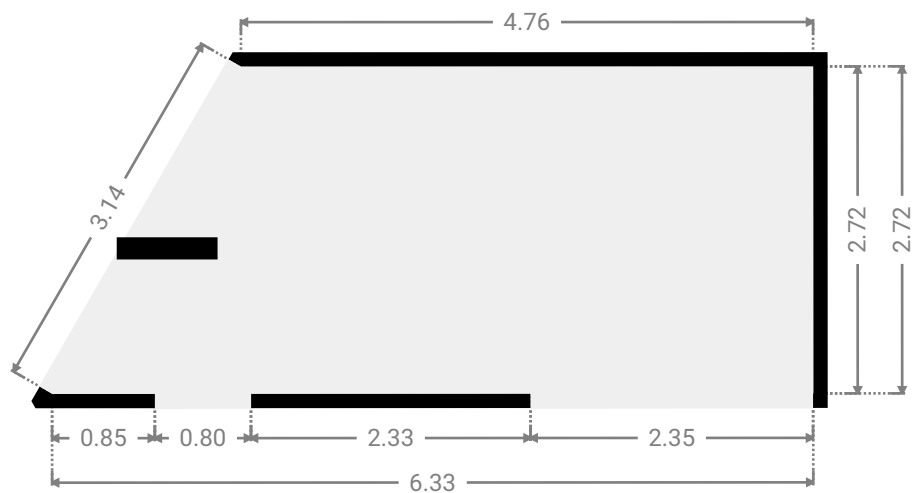
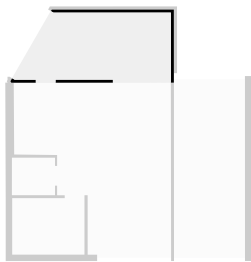

▼ **Garage**
Ground Floor

WIDTH: 2.88 m • LENGTH: 7.00 m
AREA: 20.16 m² • PERIMETER: 19.76 m

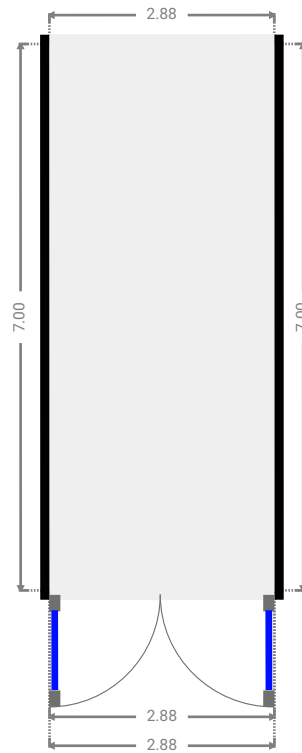
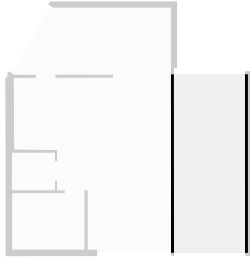

▼ 1st Floor

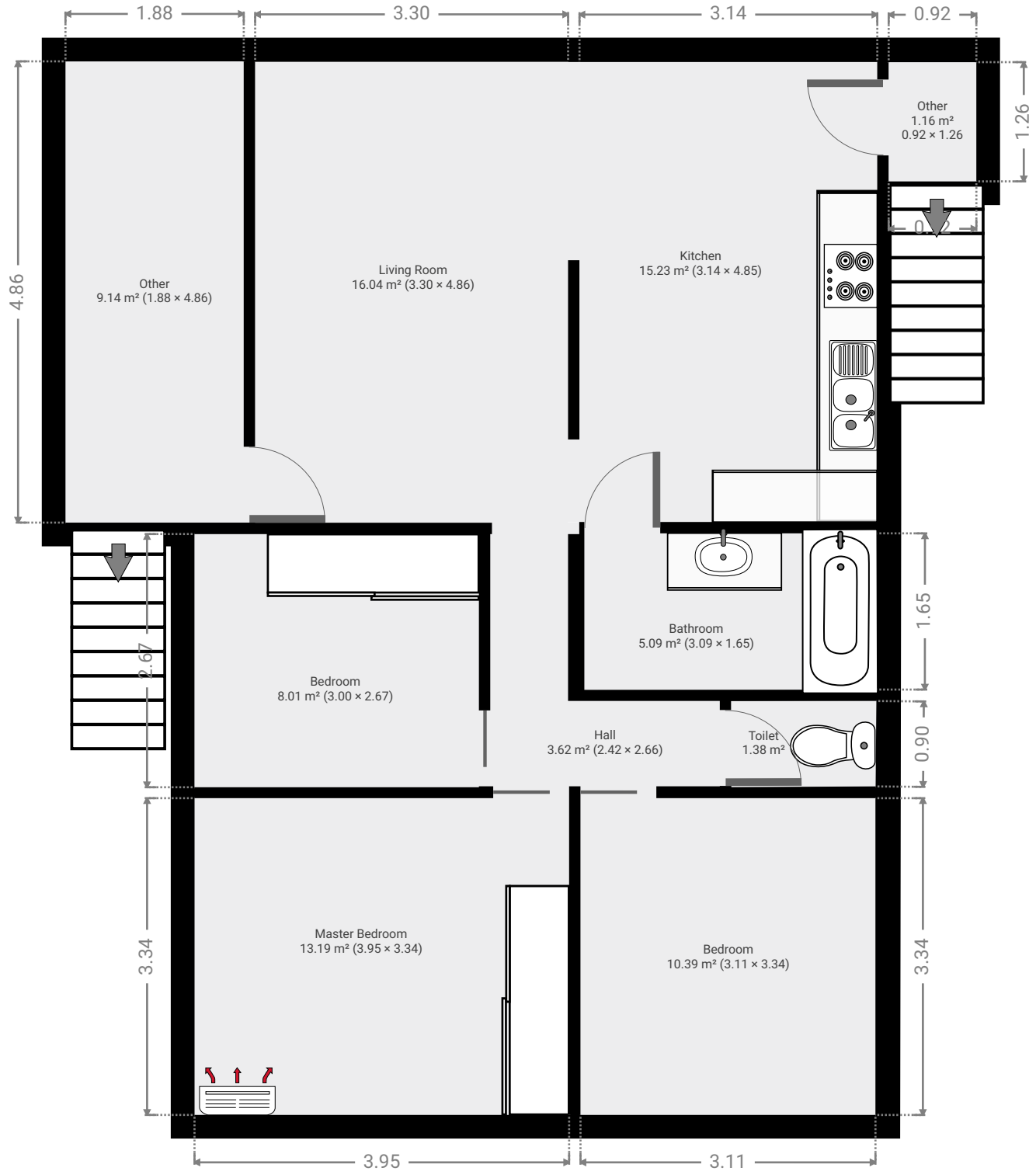

▼ **Living Room**
1st Floor

WIDTH: 4.86 m • LENGTH: 3.30 m
AREA: 16.04 m² • PERIMETER: 16.32 m

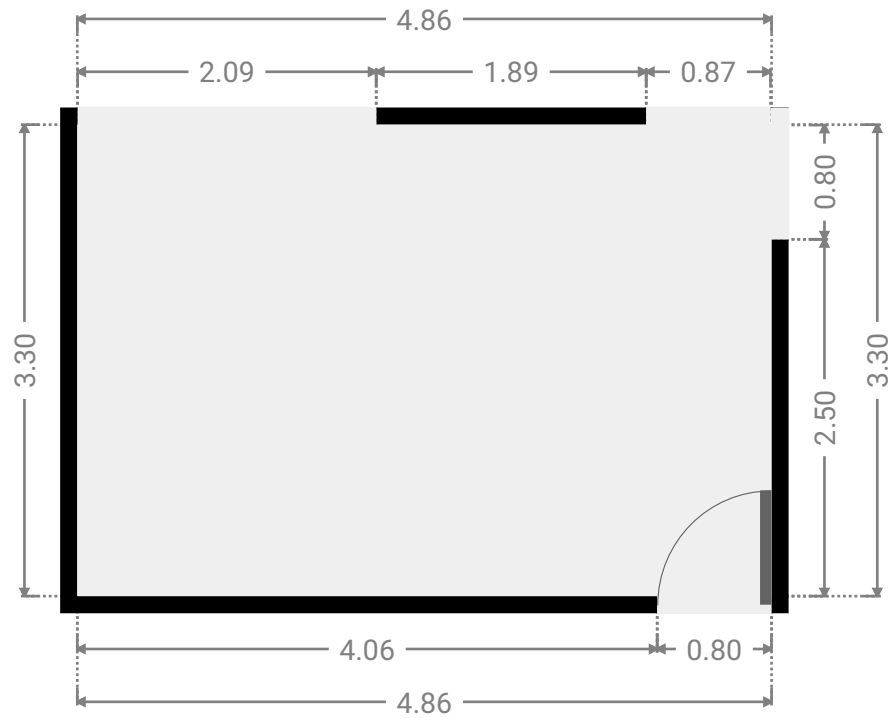
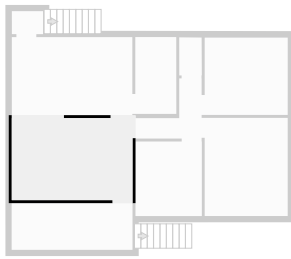

▼ **Kitchen**
1st Floor

WIDTH: 4.85 m • LENGTH: 3.14 m
AREA: 15.23 m² • PERIMETER: 15.98 m

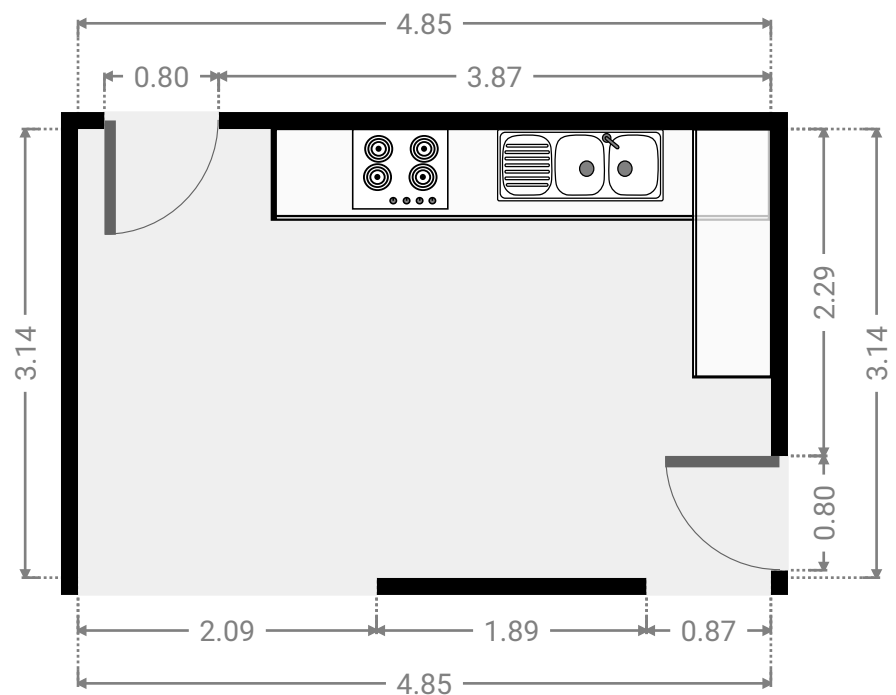
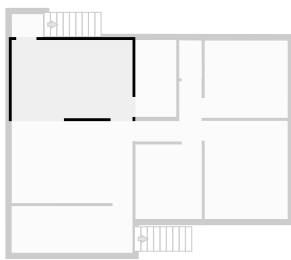

▼ Other
1st Floor

WIDTH: 1.26 m • LENGTH: 0.92 m
AREA: 1.16 m² • PERIMETER: 4.36 m

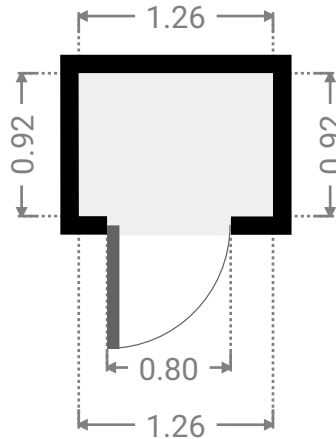
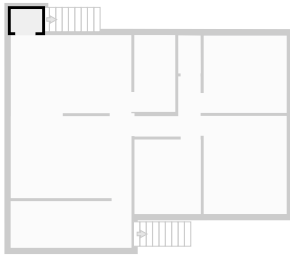

▼ Other
1st Floor

WIDTH: 4.86 m • LENGTH: 1.88 m
AREA: 9.14 m² • PERIMETER: 13.49 m

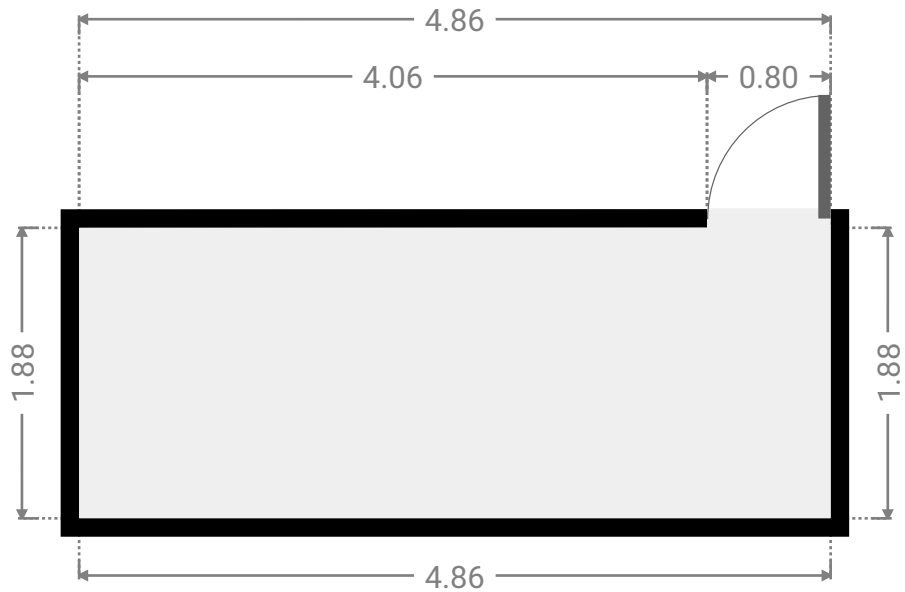
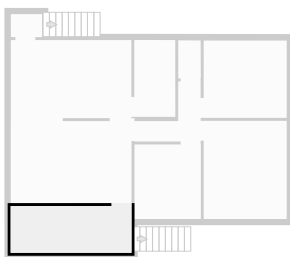

▼ **Hall**
1st Floor

WIDTH: 2.66 m • LENGTH: 2.42 m
AREA: 3.62 m² • PERIMETER: 10.16 m

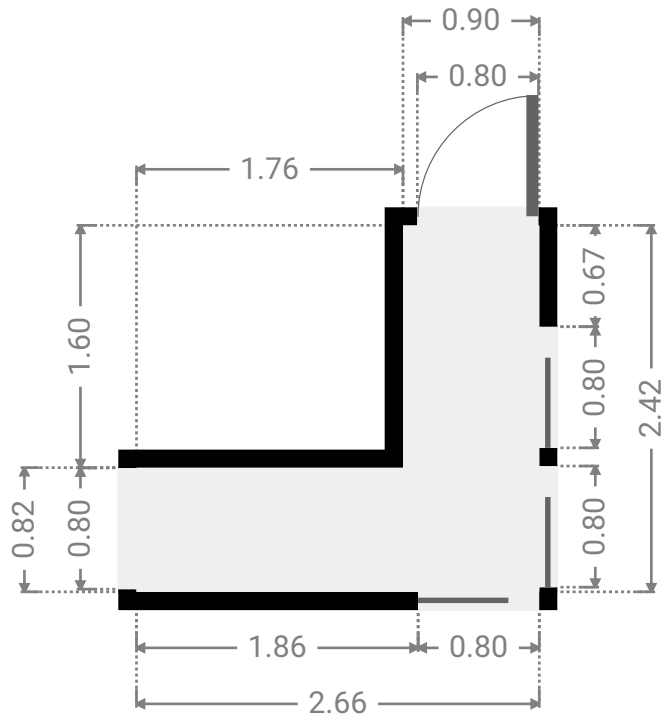
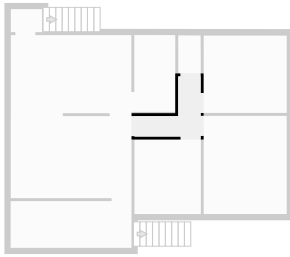

▼ **Bedroom**
1st Floor

WIDTH: 2.67 m • LENGTH: 3.00 m
AREA: 8.01 m² • PERIMETER: 11.34 m

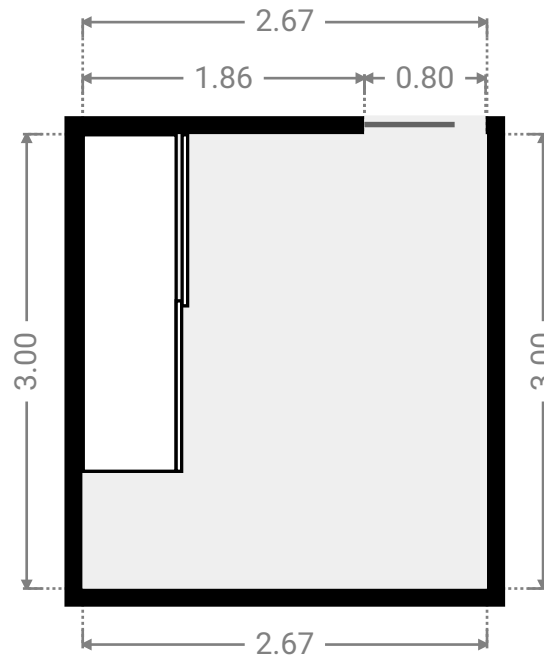
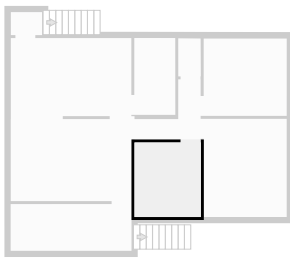

▼ **Master Bedroom**
1st Floor

WIDTH: 3.34 m • LENGTH: 3.95 m
AREA: 13.19 m² • PERIMETER: 14.58 m

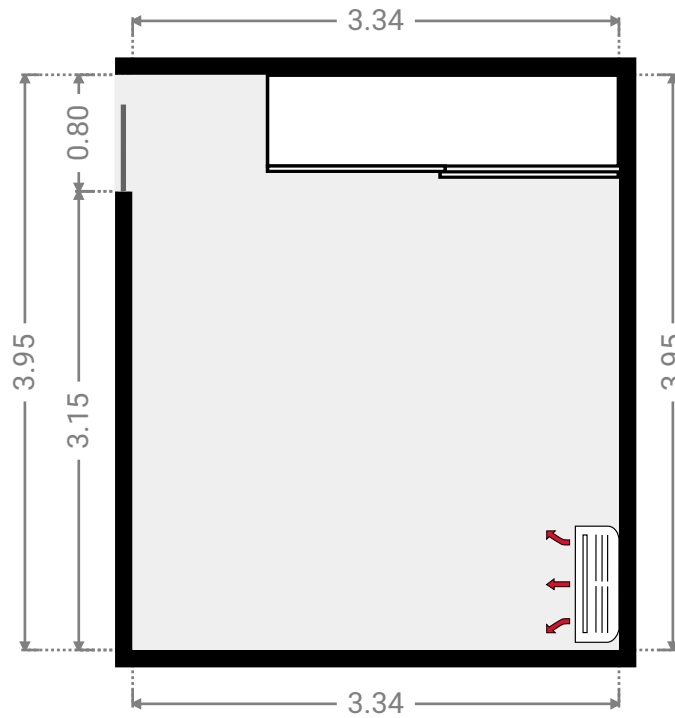
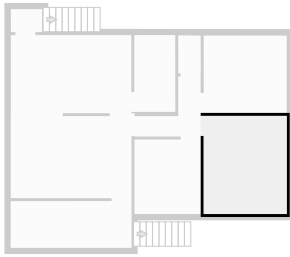

▼ **Bedroom**
1st Floor

WIDTH: 3.34 m • LENGTH: 3.11 m
AREA: 10.39 m² • PERIMETER: 12.90 m

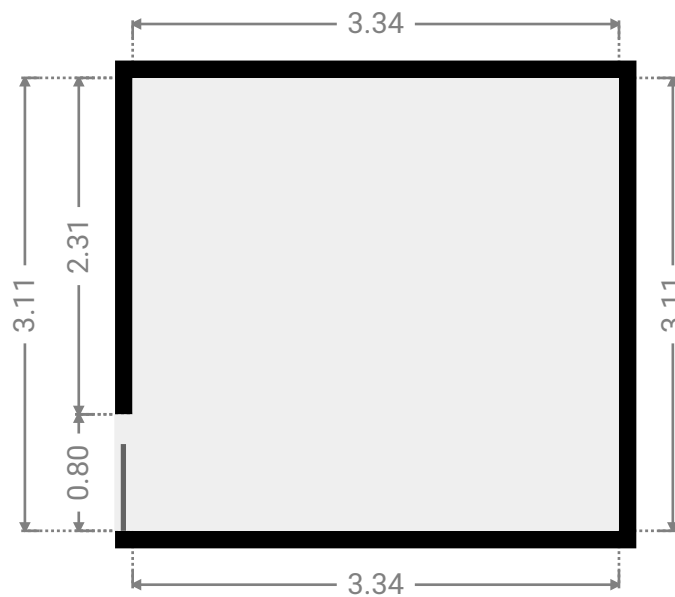
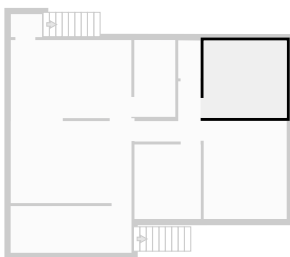

▼ **Toilet**
1st Floor

WIDTH: 0.91 m • LENGTH: 1.53 m
AREA: 1.38 m² • PERIMETER: 4.86 m

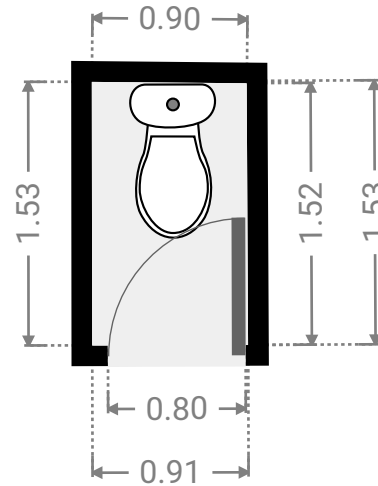
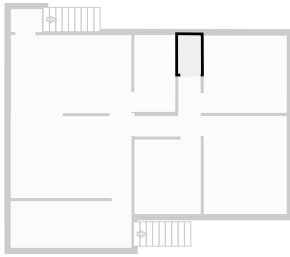

▼ **Bathroom**
1st Floor

WIDTH: 1.65 m • LENGTH: 3.09 m
AREA: 5.09 m² • PERIMETER: 9.48 m

