

# 254 William Street

**SUBMITTED BY**

Ray White Rockhampton Casey  
stockers@cqoz.com

---

**CREATED ON**

2022-05-30

---

**Floors**

2

---

▼ Ground Floor

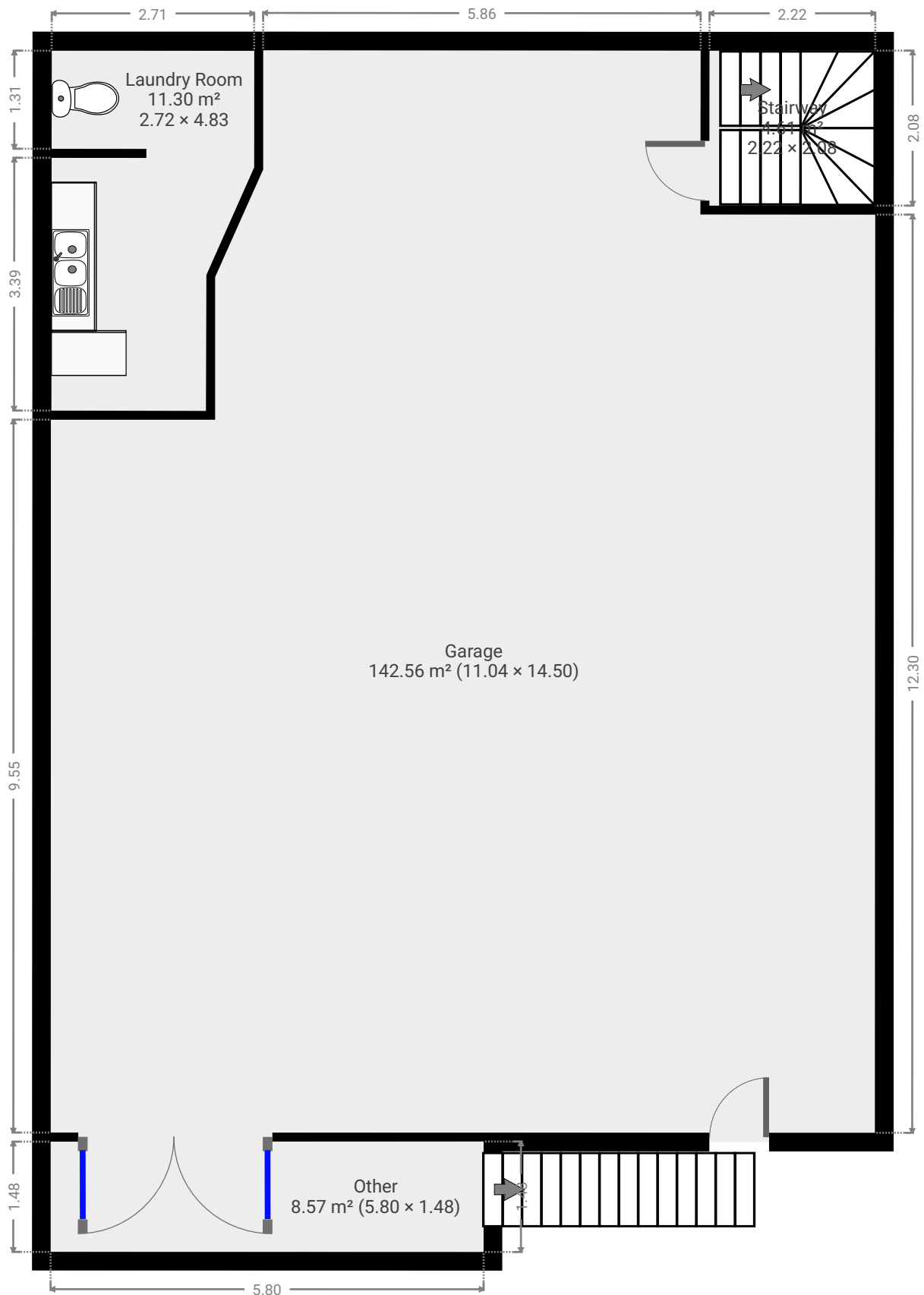

▼ **Garage**  
Ground Floor

WIDTH: 11.04 m • LENGTH: 14.50 m  
AREA: 142.56 m<sup>2</sup> • PERIMETER: 50.57 m

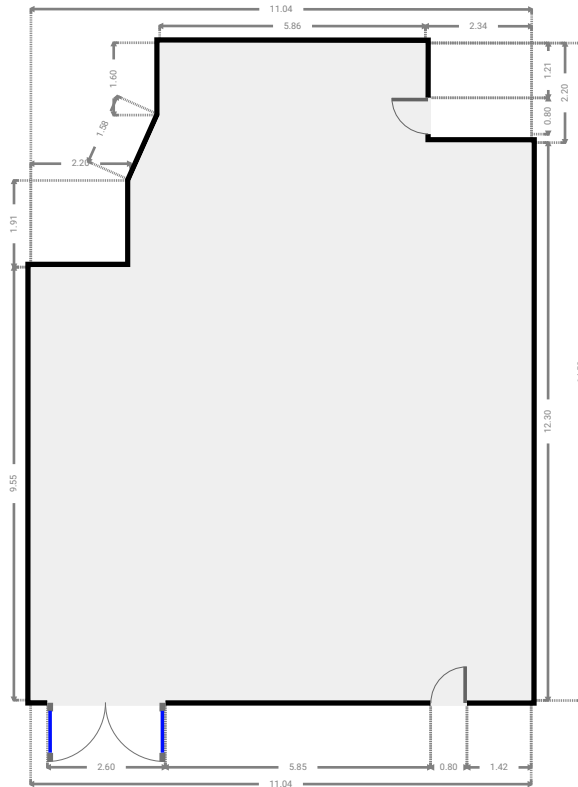
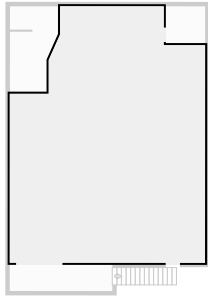

▼ **Laundry Room**  
Ground Floor

WIDTH: 2.72 m • LENGTH: 4.83 m  
AREA: 11.30 m<sup>2</sup> • PERIMETER: 17.10 m

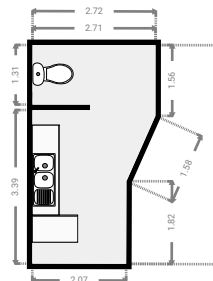
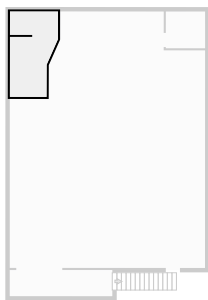

▼ **Other**  
Ground Floor

WIDTH: 5.80 m • LENGTH: 1.48 m  
AREA: 8.57 m<sup>2</sup> • PERIMETER: 14.56 m

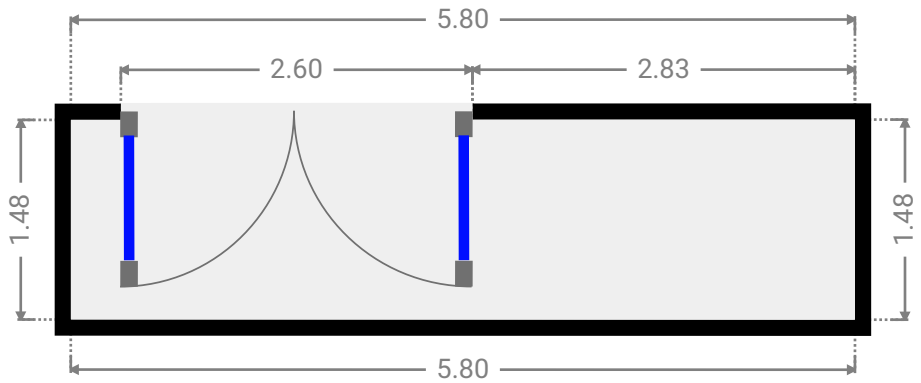
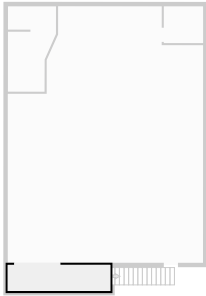

▼ **Stairway**  
Ground Floor

WIDTH: 2.22 m • LENGTH: 2.08 m  
AREA: 4.61 m<sup>2</sup> • PERIMETER: 8.59 m

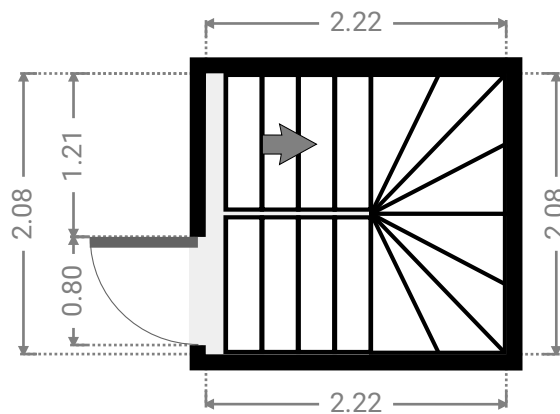
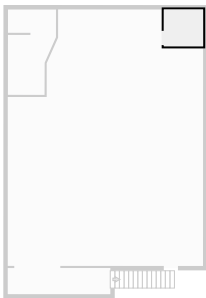

▼ 1st Floor

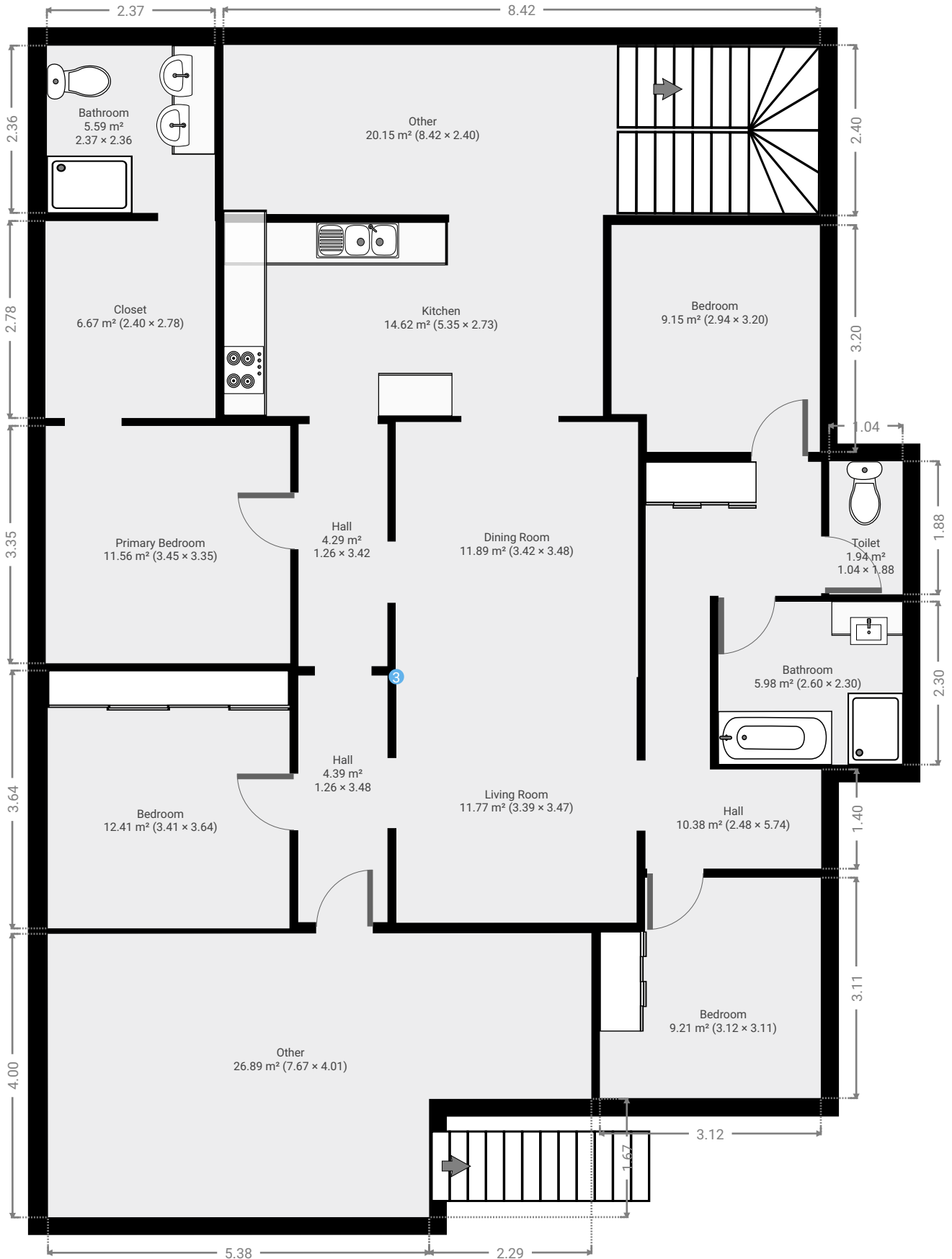

▼ **Bathroom**  
1st Floor

WIDTH: 2.60 m • LENGTH: 2.30 m  
AREA: 5.98 m<sup>2</sup> • PERIMETER: 9.80 m

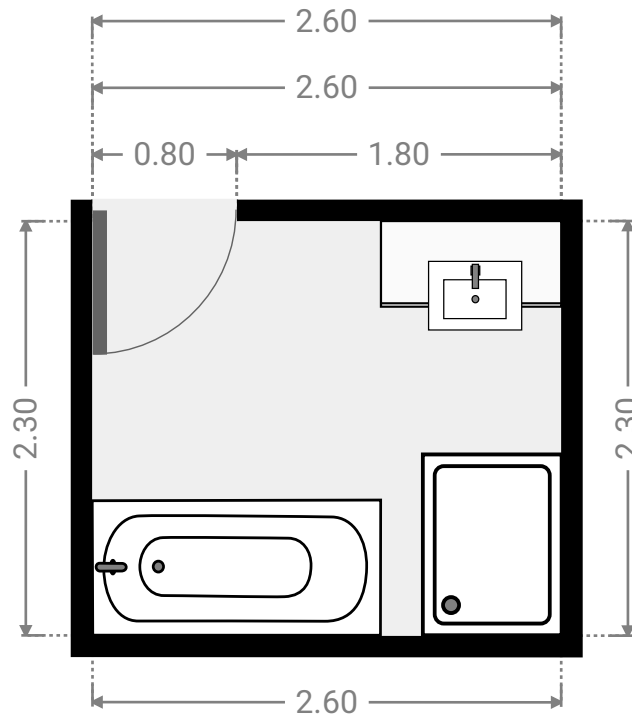
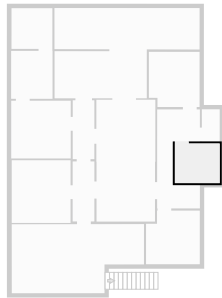

▼ **Bathroom**  
1st Floor

WIDTH: 2.37 m • LENGTH: 2.36 m  
AREA: 5.59 m<sup>2</sup> • PERIMETER: 9.46 m

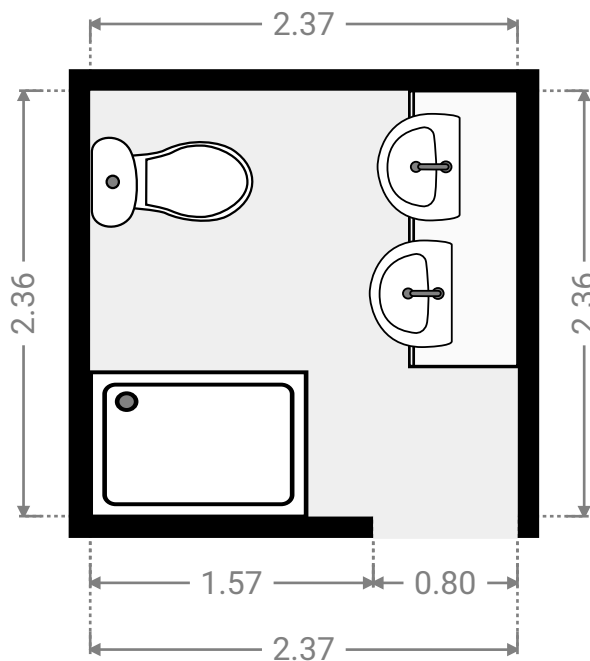
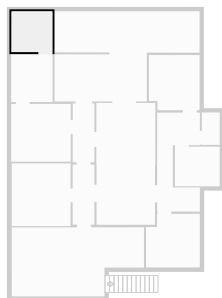

▼ **Bedroom**  
1st Floor

WIDTH: 3.41 m • LENGTH: 3.64 m  
AREA: 12.41 m<sup>2</sup> • PERIMETER: 14.10 m

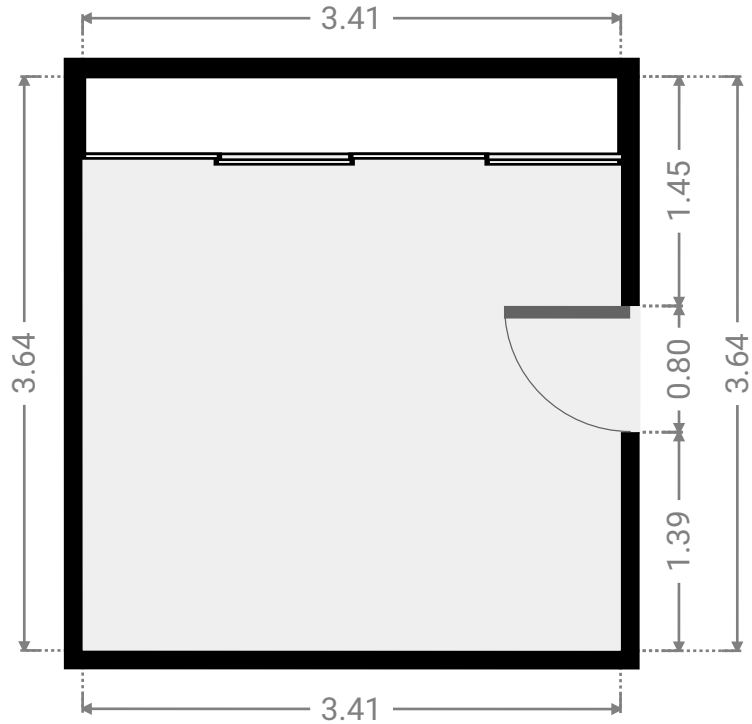
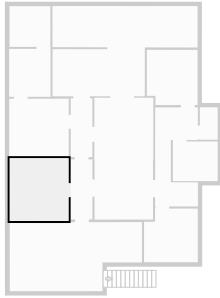

▼ **Bedroom**  
1st Floor

WIDTH: 3.12 m • LENGTH: 3.11 m  
AREA: 9.21 m<sup>2</sup> • PERIMETER: 12.46 m

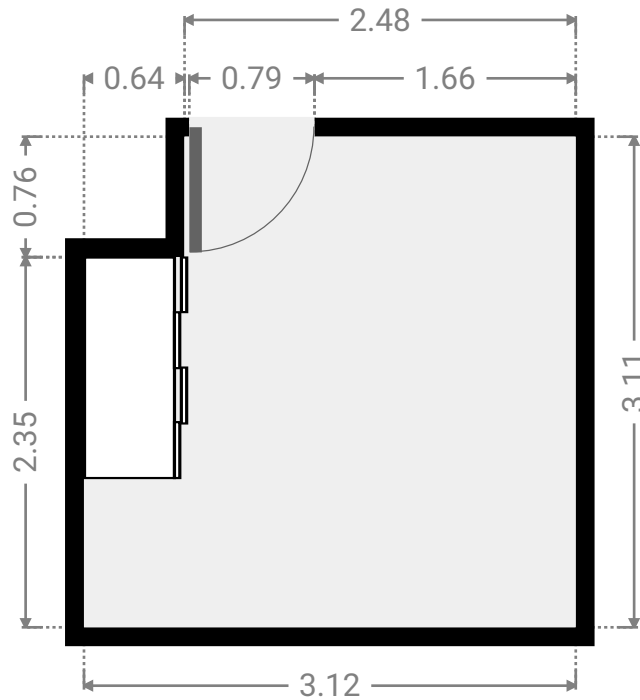
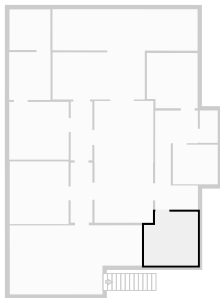

▼ **Bedroom**  
1st Floor

WIDTH: 2.94 m • LENGTH: 3.20 m  
AREA: 9.15 m<sup>2</sup> • PERIMETER: 12.28 m

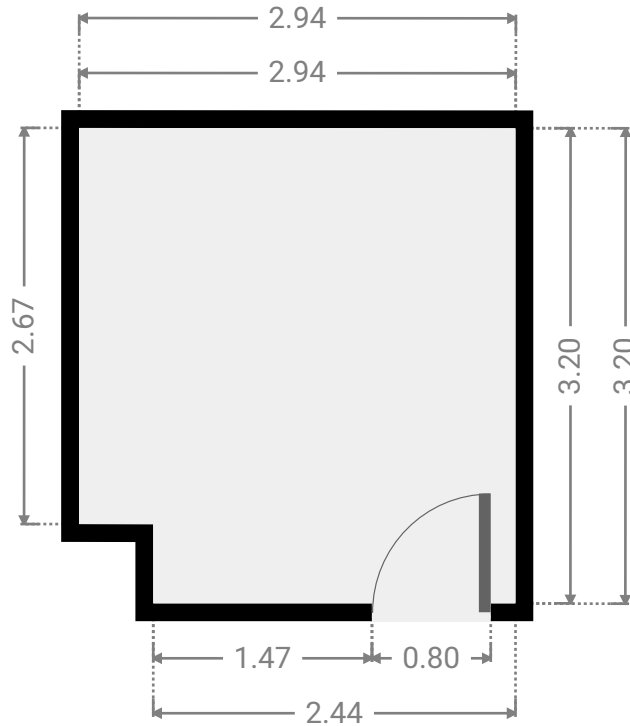
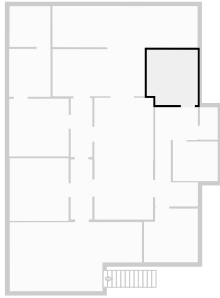

▼ **Closet**  
1st Floor

WIDTH: 2.40 m • LENGTH: 2.78 m  
AREA: 6.67 m<sup>2</sup> • PERIMETER: 10.36 m

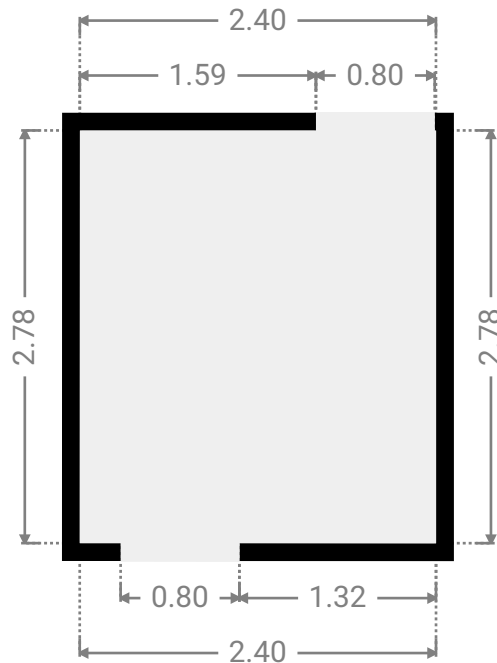
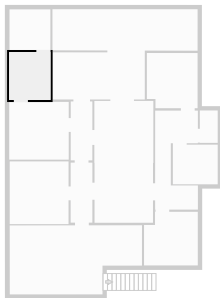



▼ Dining Room  
1st Floor

WIDTH: 3.42 m • LENGTH: 3.48 m  
AREA: 11.89 m<sup>2</sup> • PERIMETER: 13.80 m

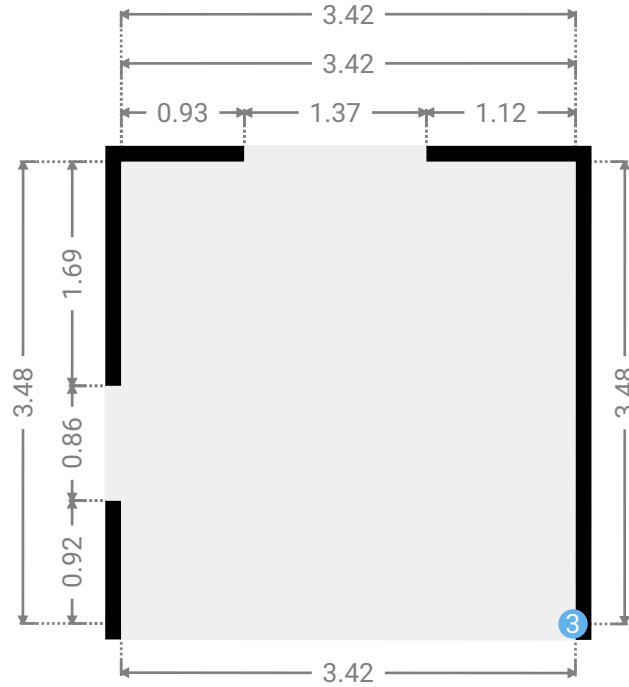
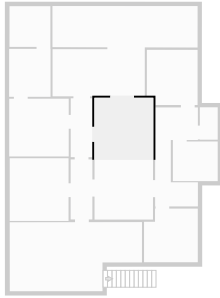

▼ Hall  
1st Floor

WIDTH: 1.26 m • LENGTH: 3.48 m  
AREA: 4.39 m<sup>2</sup> • PERIMETER: 9.48 m

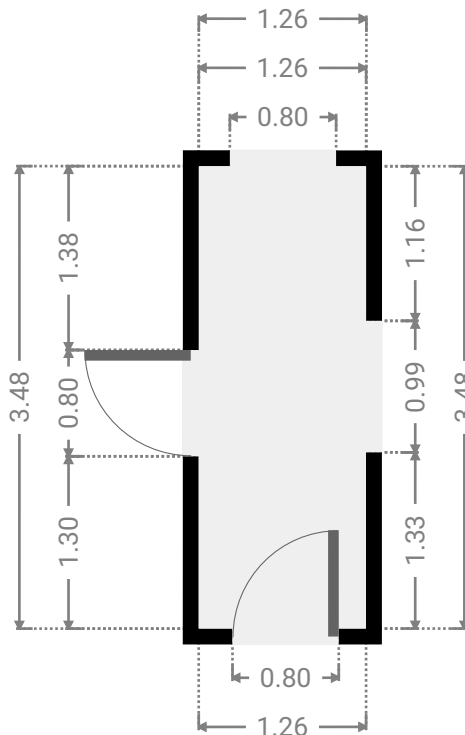
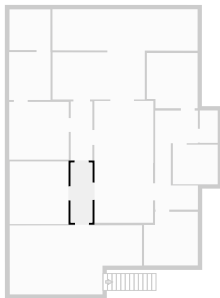

▼ Hall  
1st Floor

WIDTH: 2.48 m • LENGTH: 5.74 m  
AREA: 10.38 m<sup>2</sup> • PERIMETER: 19.58 m

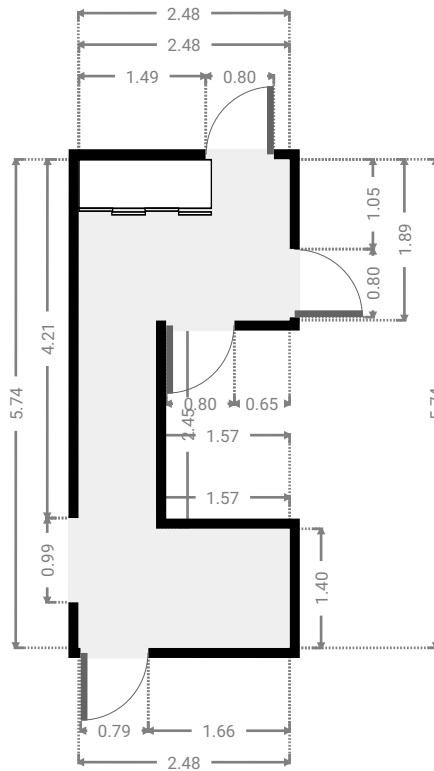
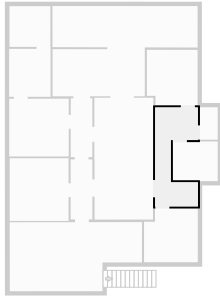

▼ Hall  
1st Floor

WIDTH: 1.26 m • LENGTH: 3.42 m  
AREA: 4.29 m<sup>2</sup> • PERIMETER: 9.34 m

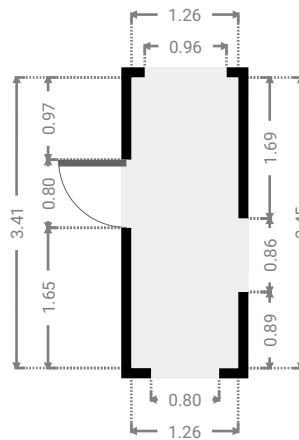
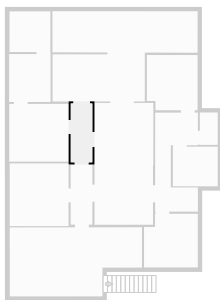

▼ **Kitchen**  
1st Floor

WIDTH: 5.35 m • LENGTH: 2.73 m  
AREA: 14.62 m<sup>2</sup> • PERIMETER: 16.16 m

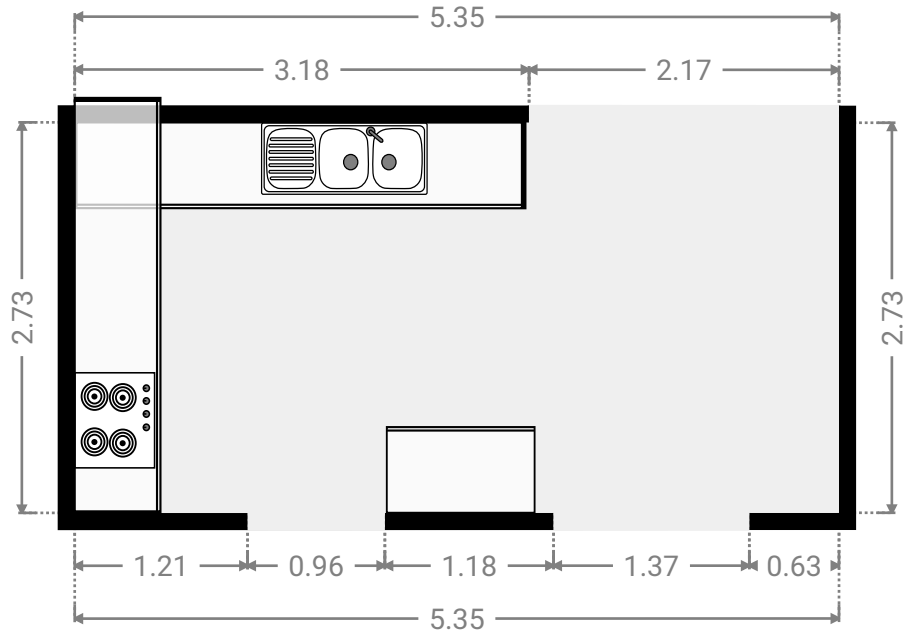
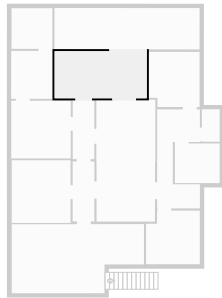

▼ **Living Room**  
1st Floor

WIDTH: 3.39 m • LENGTH: 3.47 m  
AREA: 11.77 m<sup>2</sup> • PERIMETER: 13.72 m

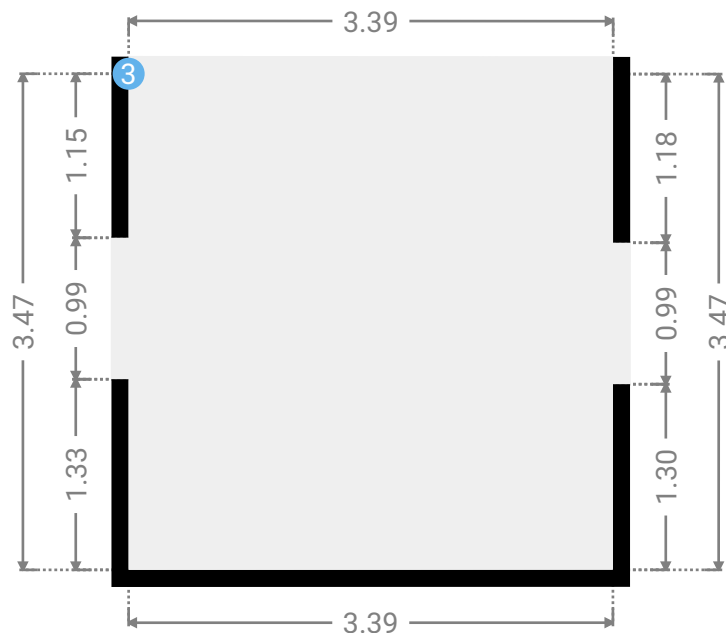
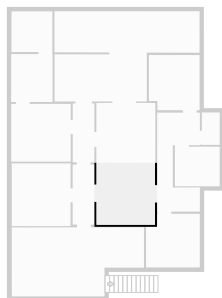

▼ Living Room/1st Floor

3 OPENING

Height  
0.00 m



▼ Other  
1st Floor

WIDTH: 8.42 m • LENGTH: 2.40 m  
AREA: 20.15 m<sup>2</sup> • PERIMETER: 21.62 m

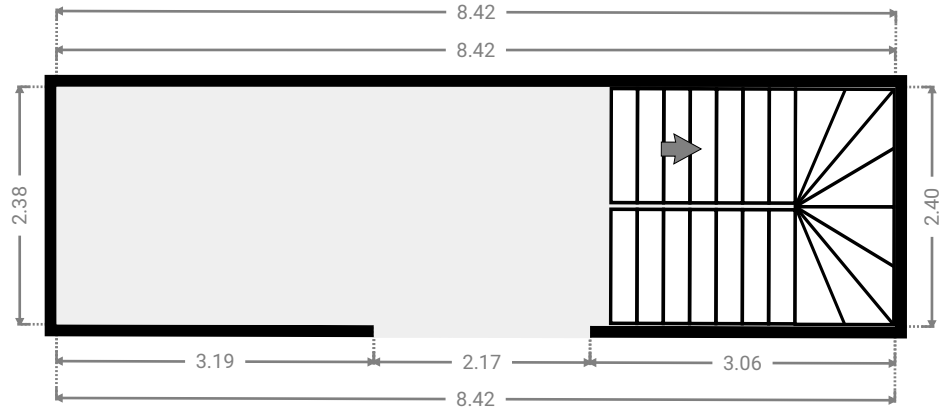
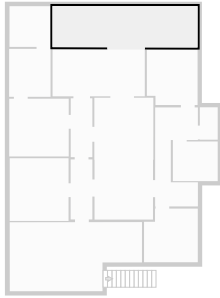

▼ Other  
1st Floor

WIDTH: 7.67 m • LENGTH: 4.01 m  
AREA: 26.89 m<sup>2</sup> • PERIMETER: 23.35 m

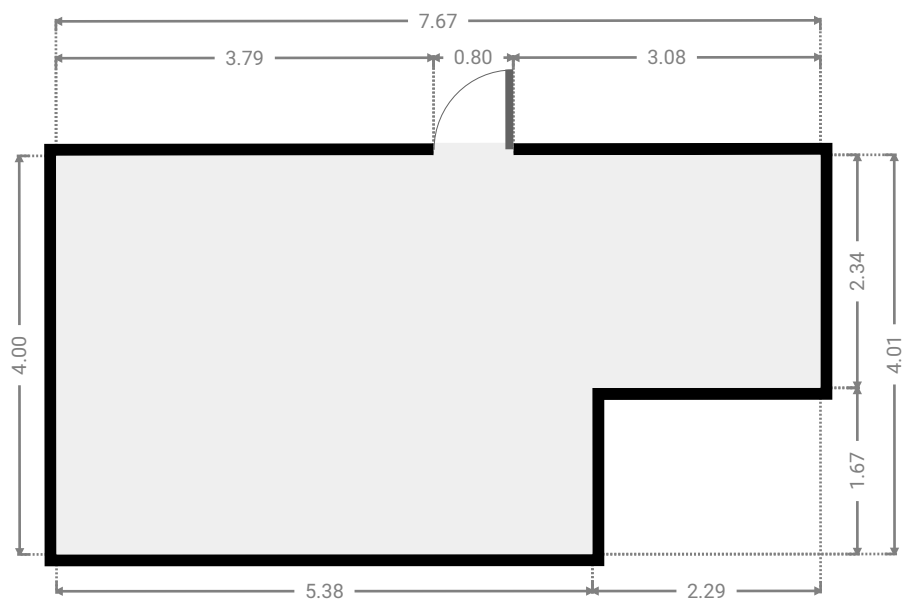
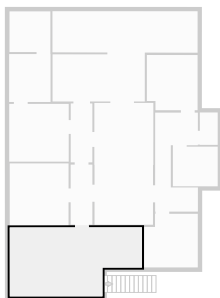

▼ **Primary Bedroom**  
1st Floor

WIDTH: 3.45 m • LENGTH: 3.35 m  
AREA: 11.56 m<sup>2</sup> • PERIMETER: 13.60 m

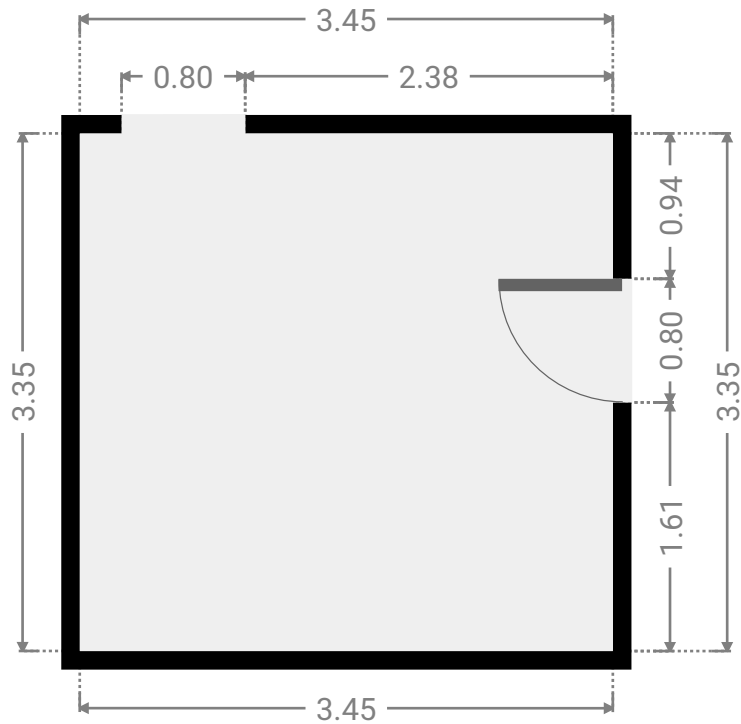
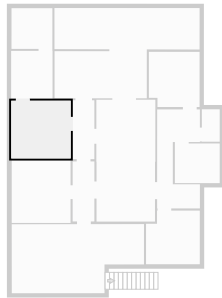

▼ **Toilet**  
1st Floor

WIDTH: 1.04 m • LENGTH: 1.88 m  
AREA: 1.94 m<sup>2</sup> • PERIMETER: 5.83 m

