

254 Roselt Street

SUBMITTED BY
Ray White Rockhampton Casey
stockers@cqoz.com

CREATED ON
2022-09-14

Floors
1

▼ Ground Floor

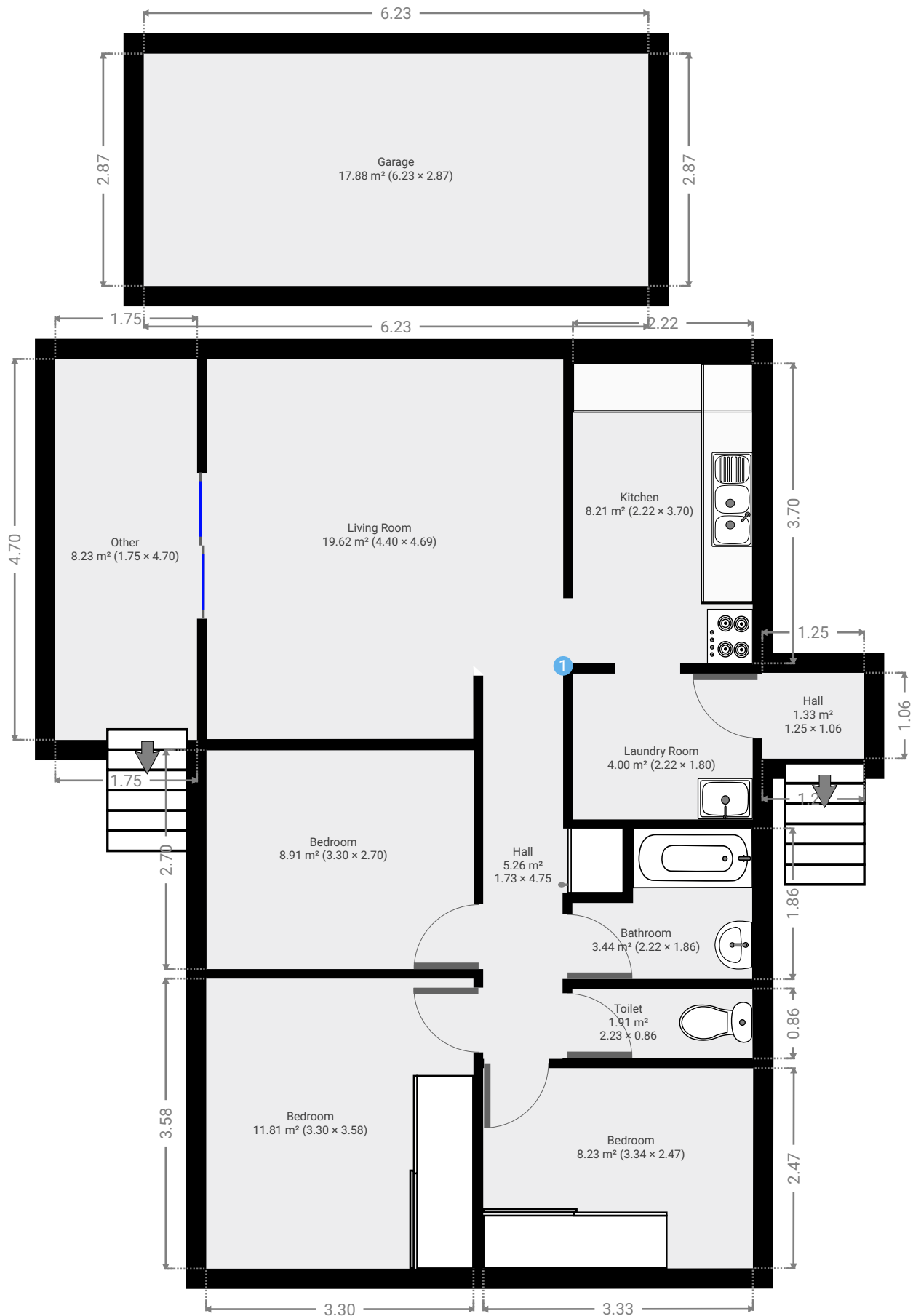

THIS FLOORPLAN IS PROVIDED WITHOUT WARRANTY OF ANY KIND. SENSOPIA DISCLAIMS ANY WARRANTY INCLUDING, WITHOUT LIMITATION, SATISFACTORY QUALITY OR ACCURACY OF DIMENSIONS.

▼ **Bathroom**
Ground Floor

WIDTH: 1.86 m • LENGTH: 2.22 m
AREA: 3.44 m² • PERIMETER: 8.16 m

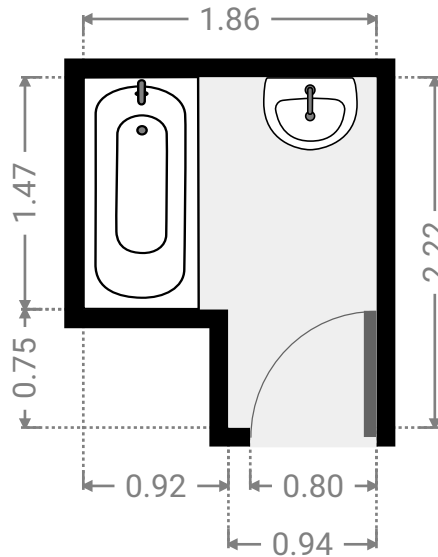
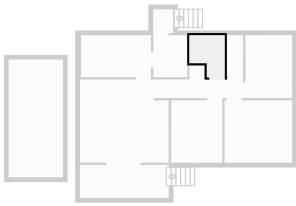

▼ **Bedroom**
Ground Floor

WIDTH: 2.70 m • LENGTH: 3.30 m
AREA: 8.91 m² • PERIMETER: 12.00 m

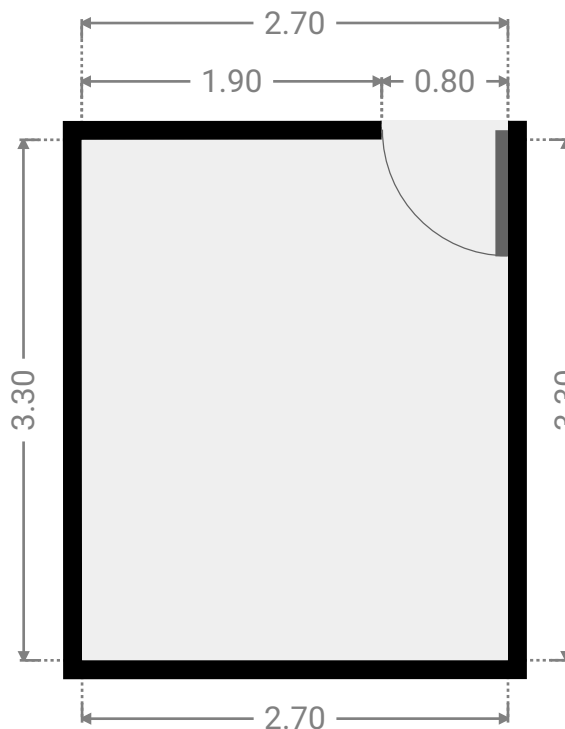
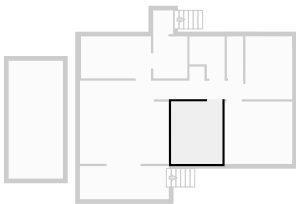

▼ **Bedroom**
Ground Floor

WIDTH: 3.58 m • LENGTH: 3.30 m
AREA: 11.81 m² • PERIMETER: 13.76 m

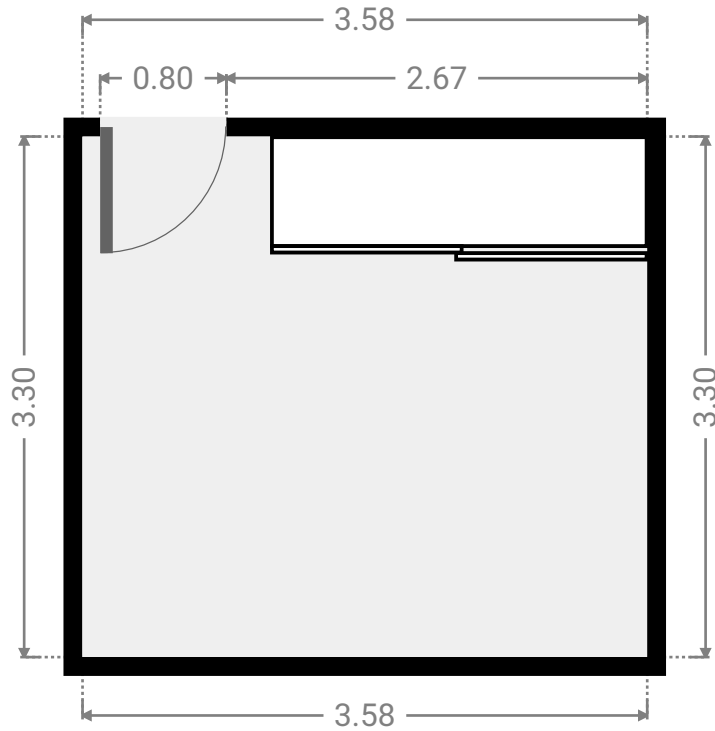
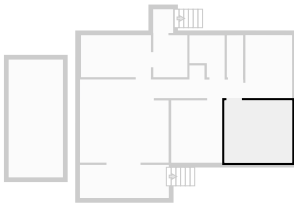

▼ **Bedroom**
Ground Floor

WIDTH: 2.47 m • LENGTH: 3.34 m
AREA: 8.23 m² • PERIMETER: 11.61 m

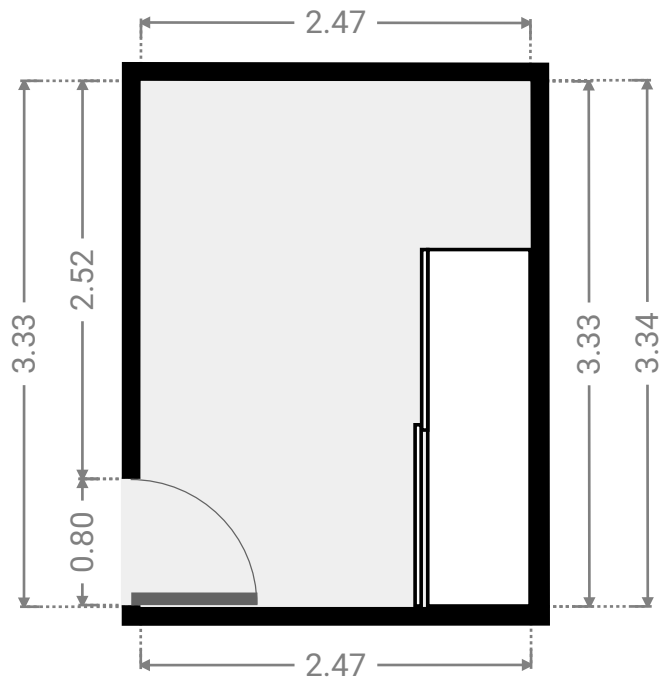
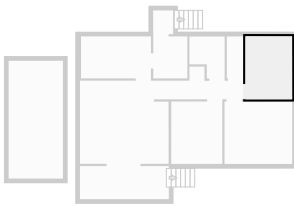

▼ **Garage**
Ground Floor

WIDTH: 2.87 m • LENGTH: 6.23 m
AREA: 17.88 m² • PERIMETER: 18.20 m

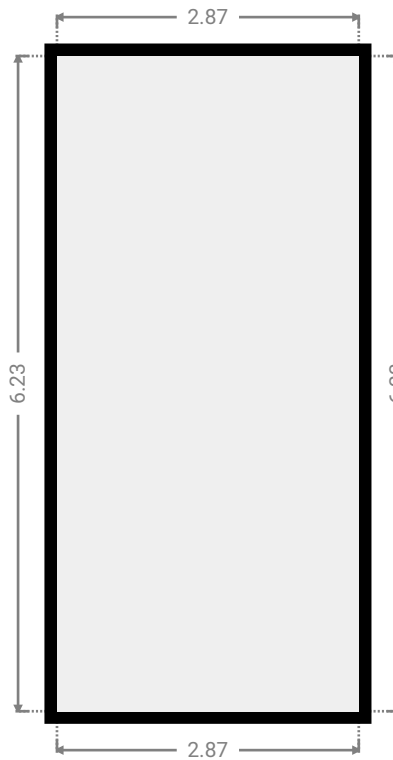
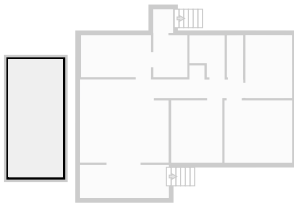

▼ **Hall**
Ground Floor

WIDTH: 4.75 m • LENGTH: 1.73 m
AREA: 5.26 m² • PERIMETER: 12.96 m

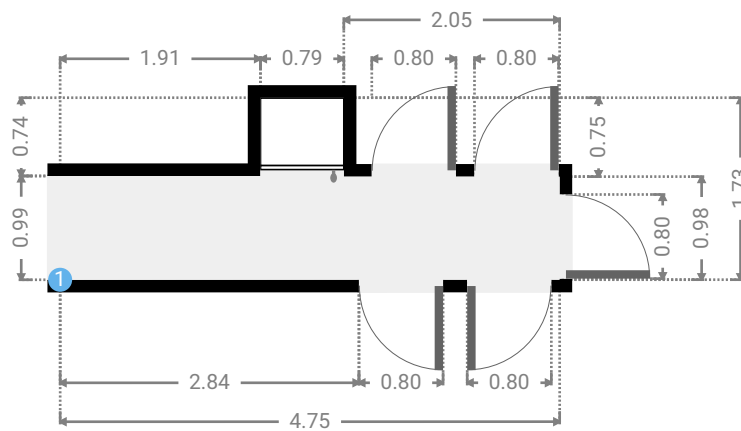
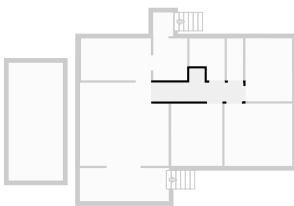

▼ **Hall**
Ground Floor

WIDTH: 1.06 m • LENGTH: 1.25 m
AREA: 1.33 m² • PERIMETER: 4.63 m

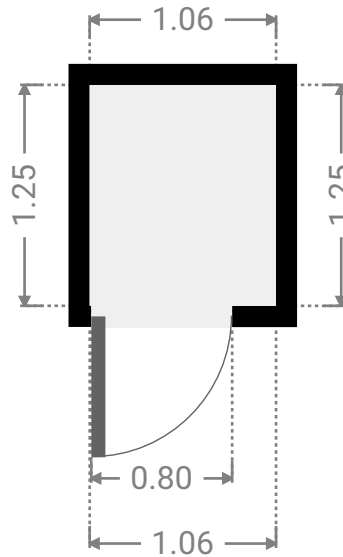
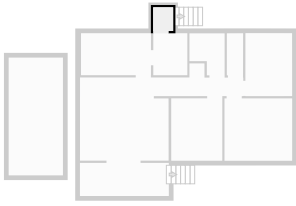

▼ **Kitchen**
Ground Floor

WIDTH: 3.70 m • LENGTH: 2.22 m
AREA: 8.21 m² • PERIMETER: 11.84 m

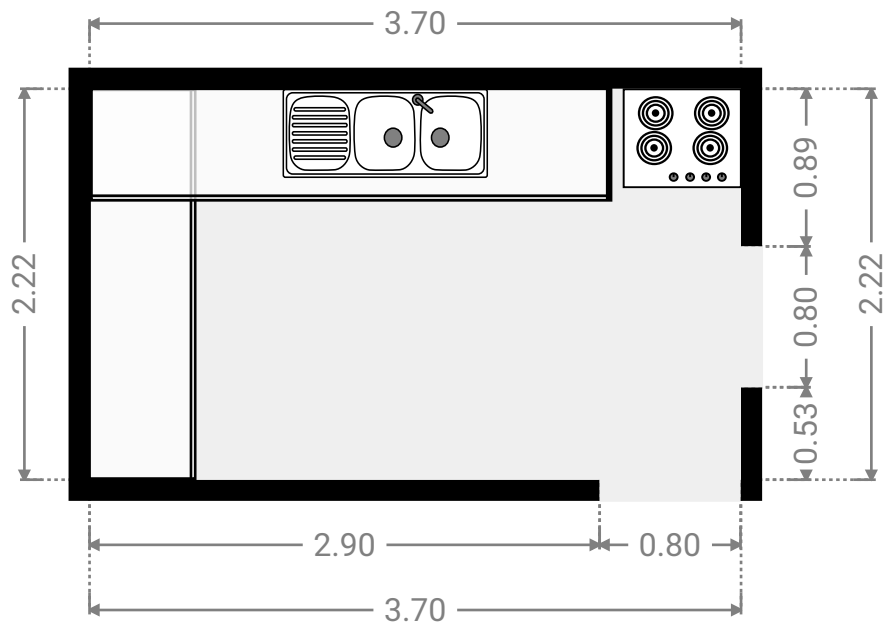
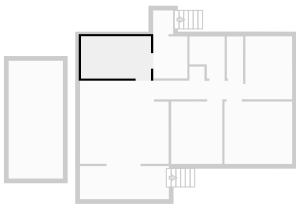

▼ **Laundry Room**
Ground Floor

WIDTH: 1.80 m • LENGTH: 2.22 m
AREA: 4.00 m² • PERIMETER: 8.04 m

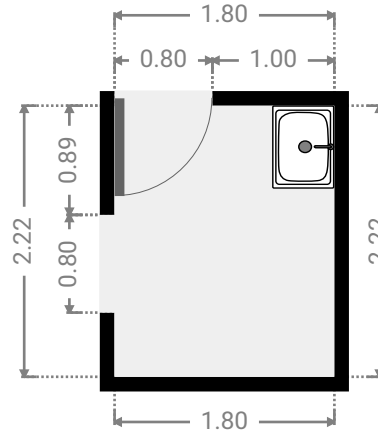
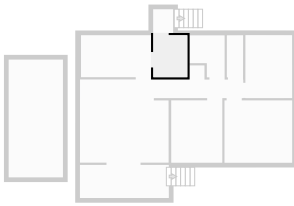

▼ **Living Room**
Ground Floor

WIDTH: 4.69 m • LENGTH: 4.40 m
AREA: 19.62 m² • PERIMETER: 18.17 m

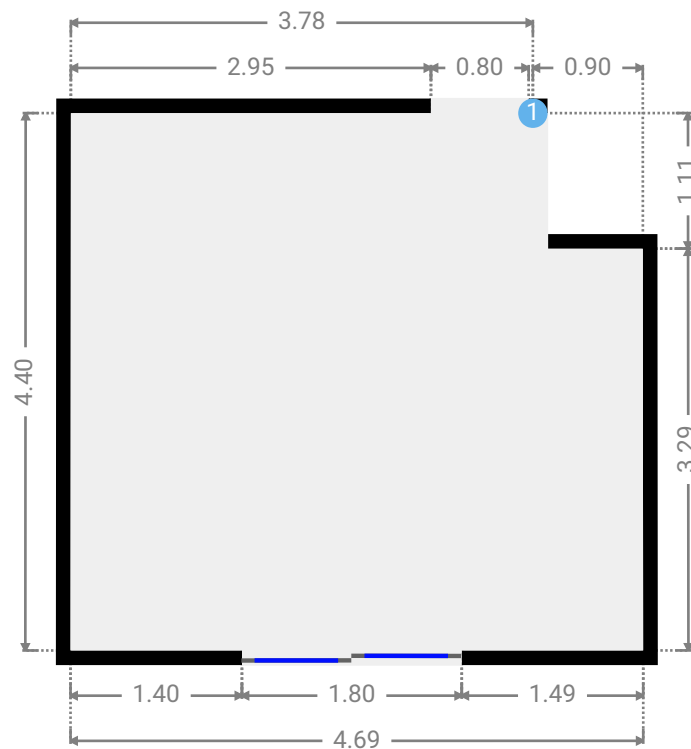
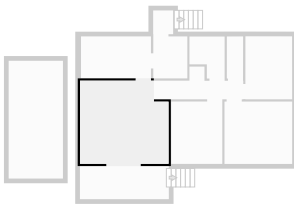

▼ Living Room/Ground Floor

1 OPENING

Height
0.00 m



▼ **Other**
Ground Floor

WIDTH: 4.70 m • LENGTH: 1.75 m
AREA: 8.23 m² • PERIMETER: 12.91 m

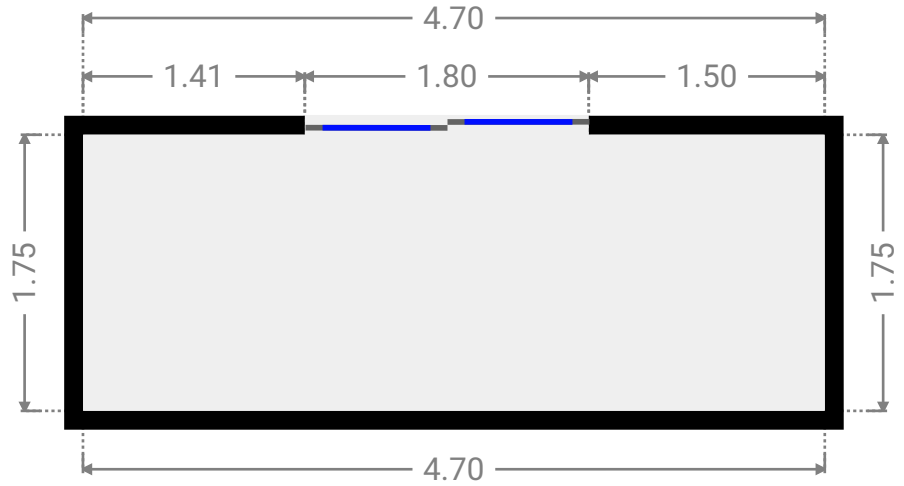
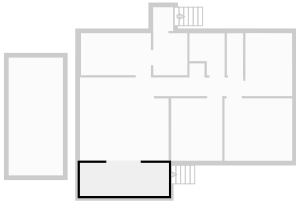

▼ **Toilet**
Ground Floor

WIDTH: 0.86 m • LENGTH: 2.23 m
AREA: 1.91 m² • PERIMETER: 6.17 m

