

252 Archer Street

SUBMITTED BY

Ray White Rockhampton Casey
stockers@cqoz.com

CREATED ON

2022-11-02

Floors

2

▼ Ground Floor

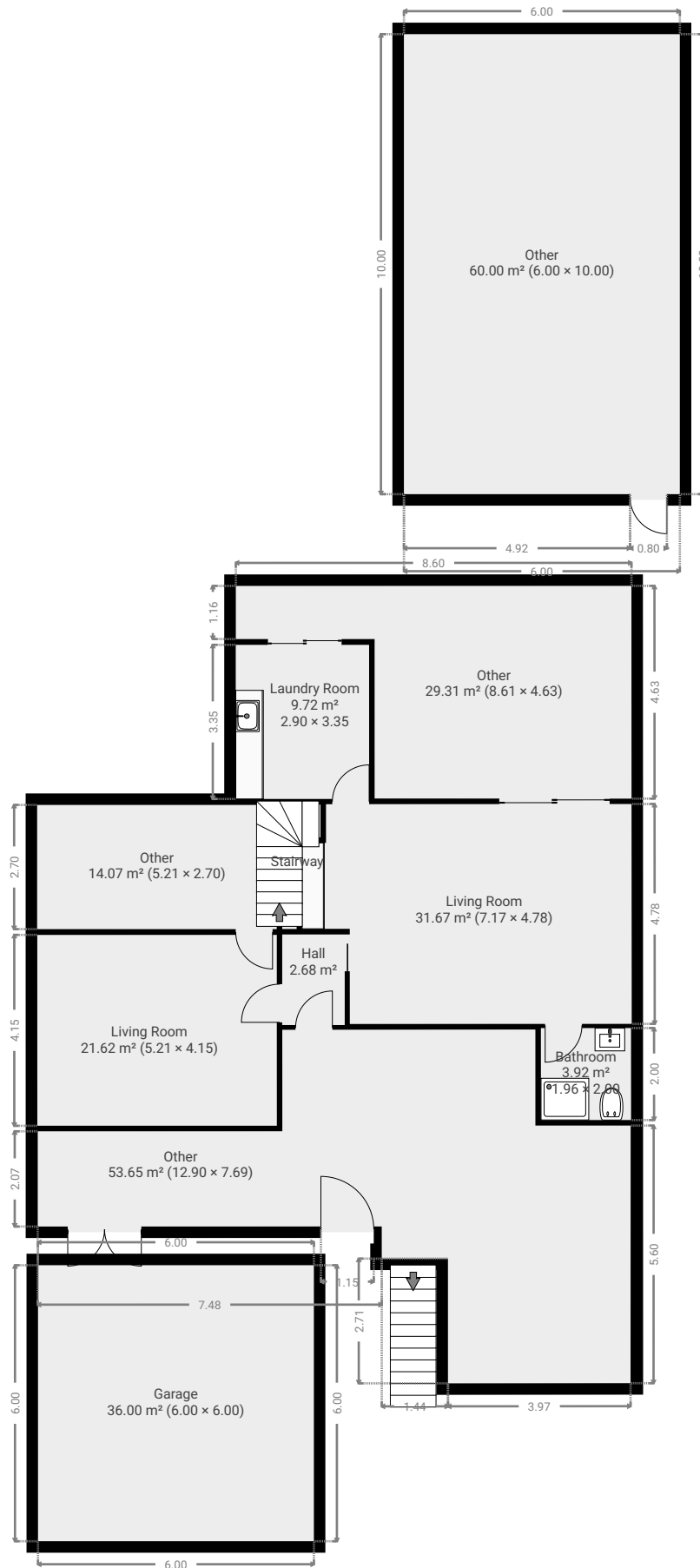

▼ **Bathroom**
Ground Floor

WIDTH: 1.96 m • LENGTH: 2.00 m
AREA: 3.92 m² • PERIMETER: 7.92 m

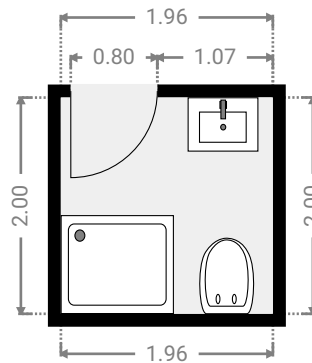

▼ **Garage**
Ground Floor

WIDTH: 6.00 m • LENGTH: 6.00 m
AREA: 36.00 m² • PERIMETER: 24.00 m

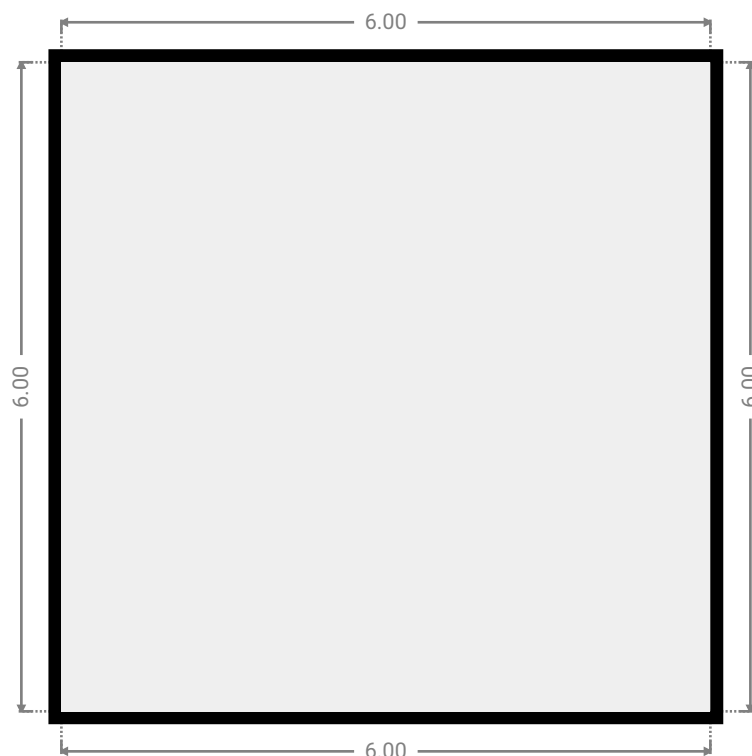
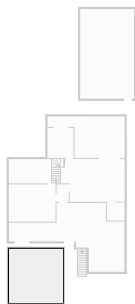

▼ **Hall**
Ground Floor

WIDTH: 1.36 m • LENGTH: 1.97 m
AREA: 2.68 m² • PERIMETER: 6.66 m

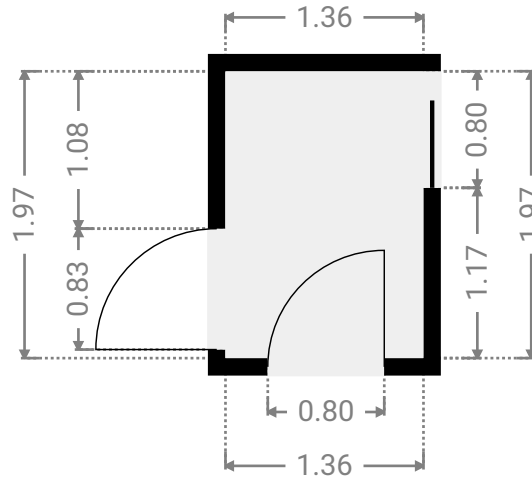
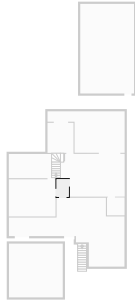

▼ **Laundry Room**
Ground Floor

WIDTH: 2.90 m • LENGTH: 3.35 m
AREA: 9.72 m² • PERIMETER: 12.50 m

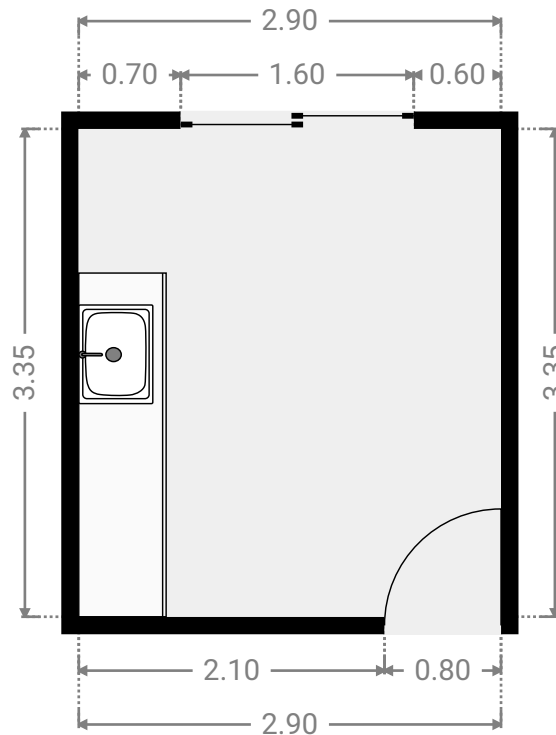
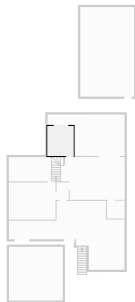

▼ Living Room
Ground Floor

WIDTH: 5.21 m • LENGTH: 4.15 m
AREA: 21.62 m² • PERIMETER: 18.72 m

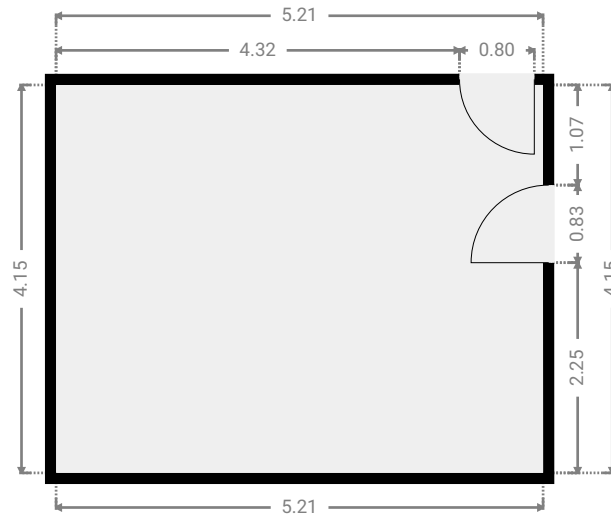
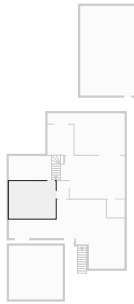

▼ Living Room
Ground Floor

WIDTH: 7.17 m • LENGTH: 4.78 m
AREA: 31.67 m² • PERIMETER: 23.89 m

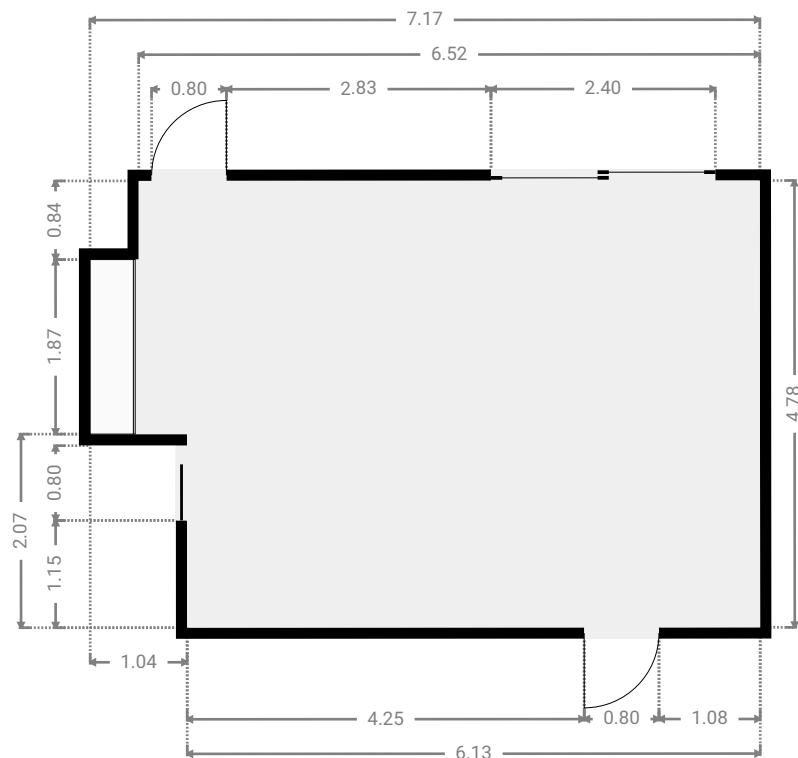
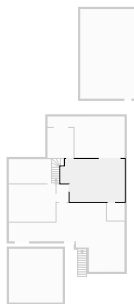

▼ Other
Ground Floor

WIDTH: 5.21 m • LENGTH: 2.70 m
AREA: 14.07 m² • PERIMETER: 15.82 m

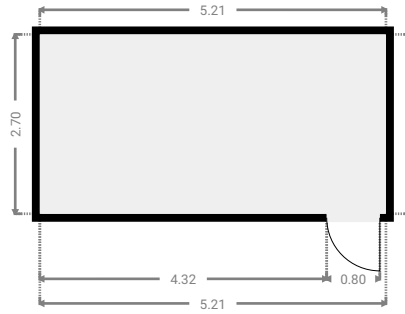
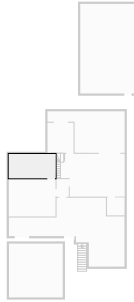

▼ Other
Ground Floor

WIDTH: 12.90 m • LENGTH: 7.69 m
AREA: 53.65 m² • PERIMETER: 41.16 m

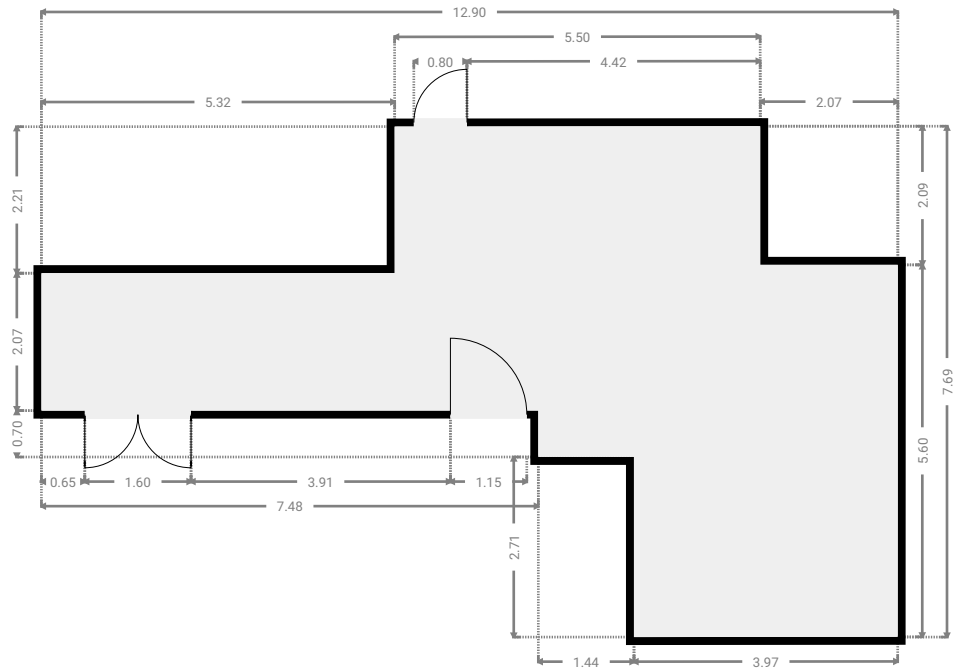
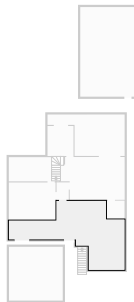

▼ Other
Ground Floor

WIDTH: 8.61 m • LENGTH: 4.63 m
AREA: 29.31 m² • PERIMETER: 26.46 m

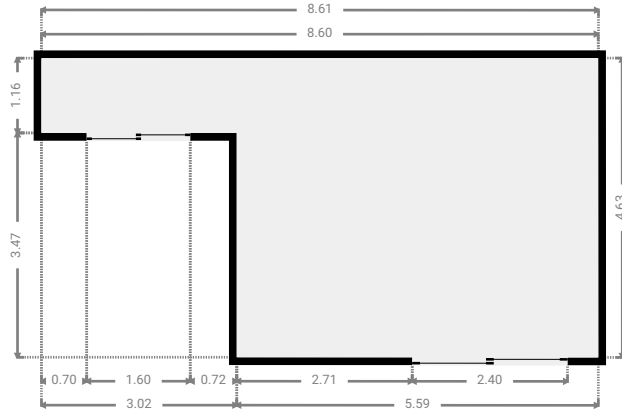
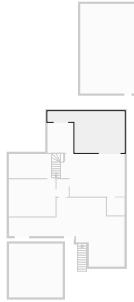

▼ Other
Ground Floor

WIDTH: 6.00 m • LENGTH: 10.00 m
AREA: 60.00 m² • PERIMETER: 32.00 m

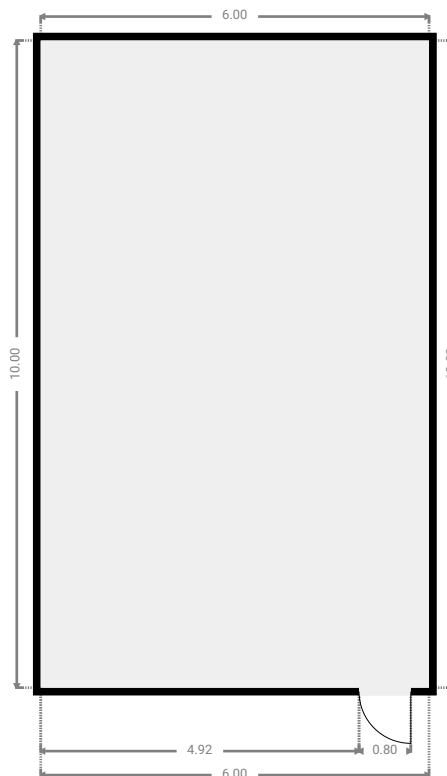
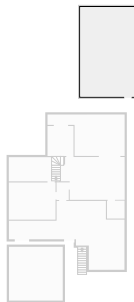

▼ **Stairway**
Ground Floor

WIDTH: 0.83 m • LENGTH: 2.70 m
AREA: 1.21 m² • PERIMETER: 7.07 m

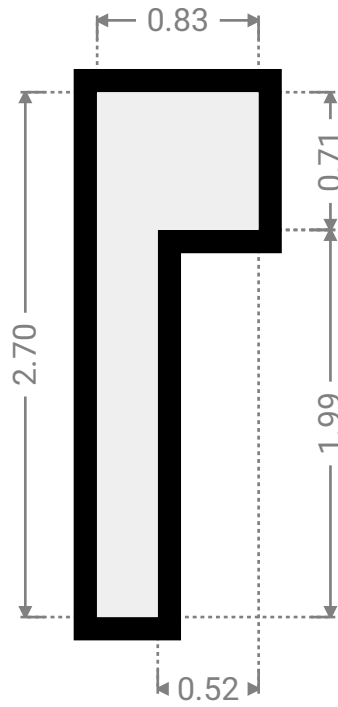
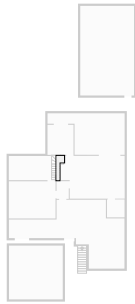

▼ 1st Floor

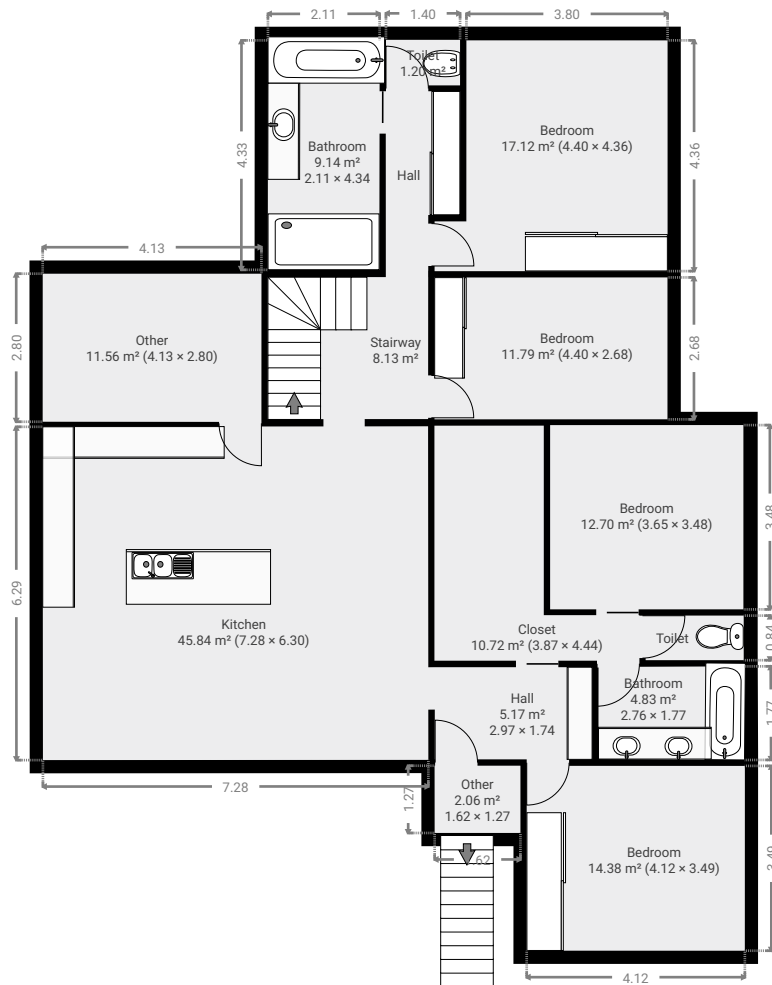

▼ **Bathroom**
1st Floor

WIDTH: 2.76 m • LENGTH: 1.77 m
AREA: 4.83 m² • PERIMETER: 9.02 m

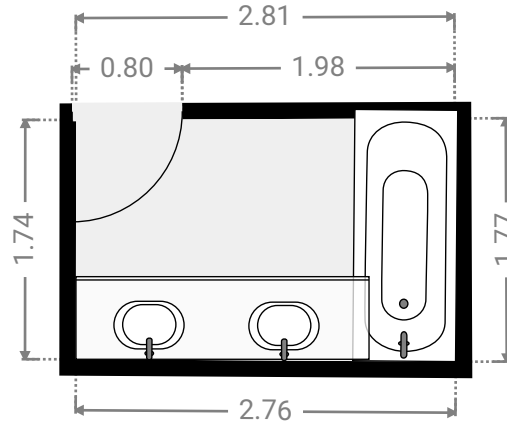
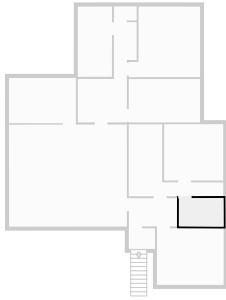

▼ **Bathroom**
1st Floor

WIDTH: 2.11 m • LENGTH: 4.34 m
AREA: 9.14 m² • PERIMETER: 12.89 m

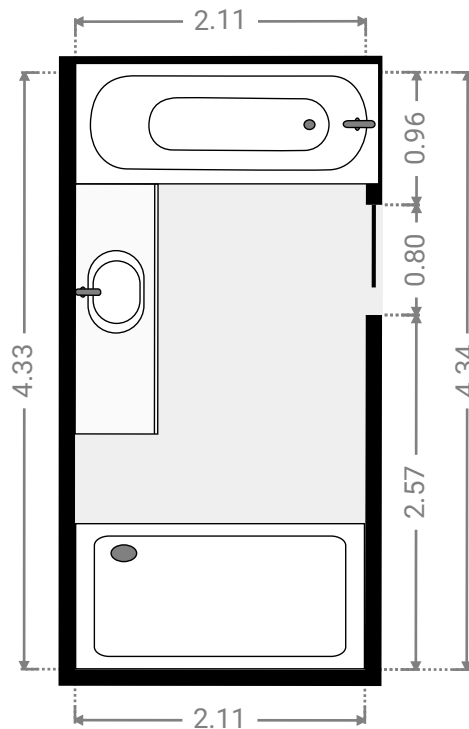
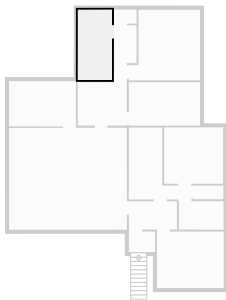

▼ **Bedroom**
1st Floor

WIDTH: 4.12 m • LENGTH: 3.49 m
AREA: 14.38 m² • PERIMETER: 15.22 m

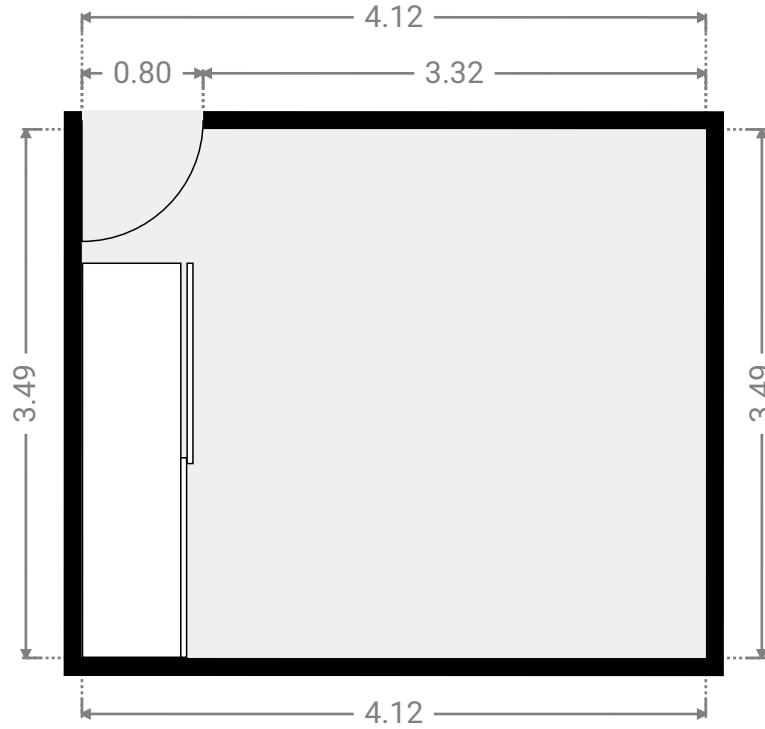
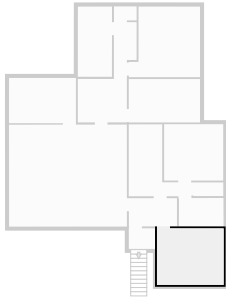

▼ **Bedroom**
1st Floor

WIDTH: 3.65 m • LENGTH: 3.48 m
AREA: 12.70 m² • PERIMETER: 14.26 m

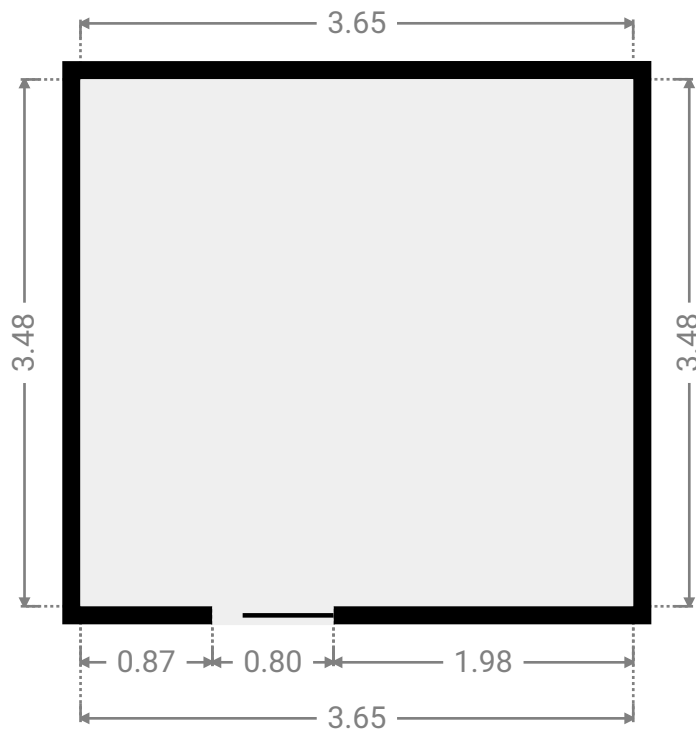
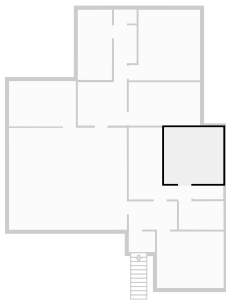

▼ **Bedroom**
1st Floor

WIDTH: 4.40 m • LENGTH: 2.68 m
AREA: 11.79 m² • PERIMETER: 14.16 m

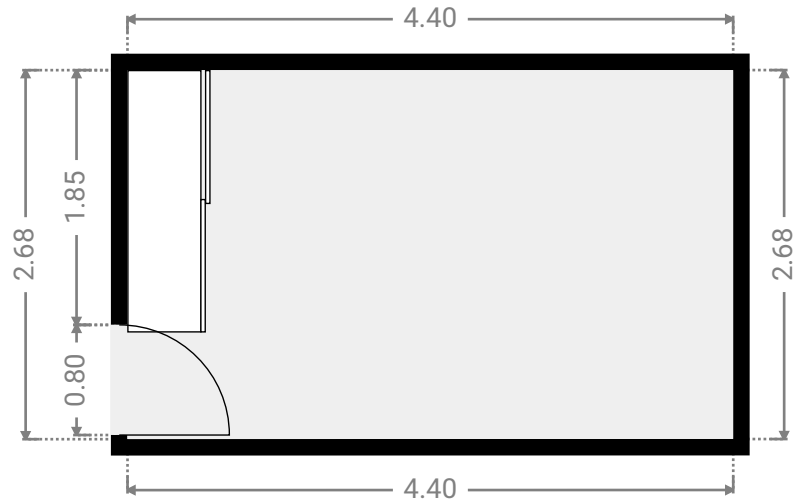
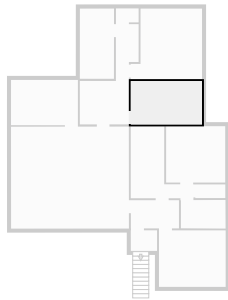

▼ **Bedroom**
1st Floor

WIDTH: 4.40 m • LENGTH: 4.36 m
AREA: 17.12 m² • PERIMETER: 17.52 m

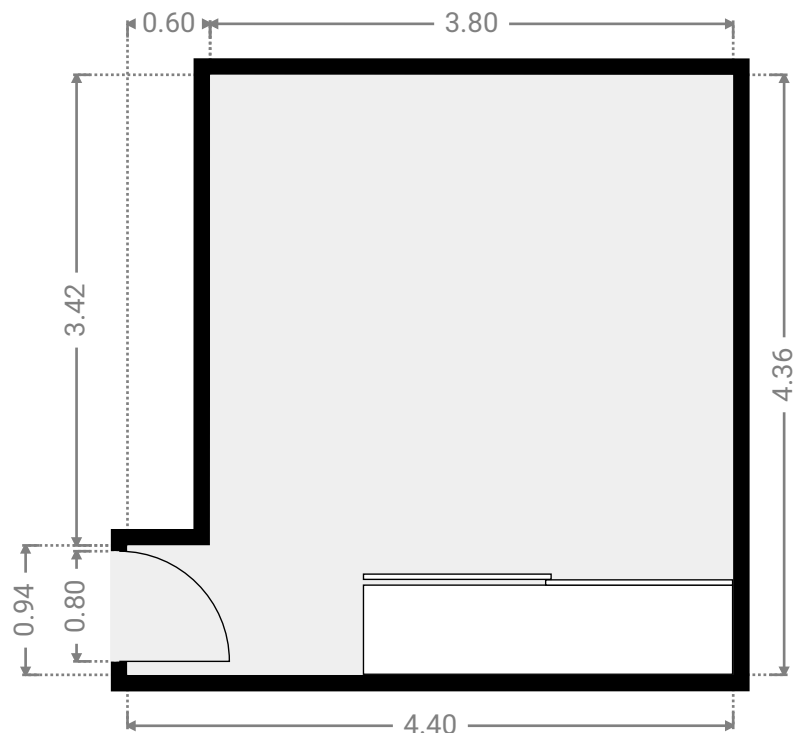
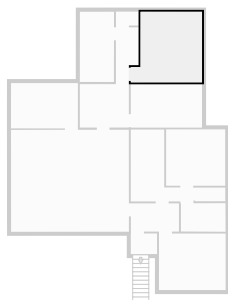

▼ **Closet**
1st Floor

WIDTH: 3.87 m • LENGTH: 4.44 m
AREA: 10.72 m² • PERIMETER: 16.62 m

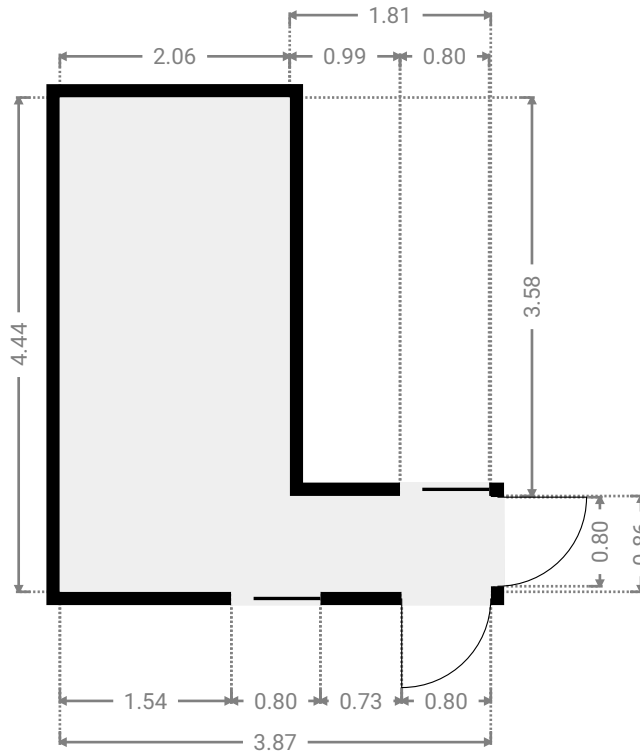
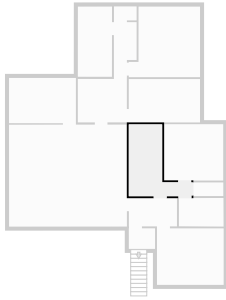

▼ **Hall**
1st Floor

WIDTH: 2.97 m • LENGTH: 1.74 m
AREA: 5.17 m² • PERIMETER: 9.42 m

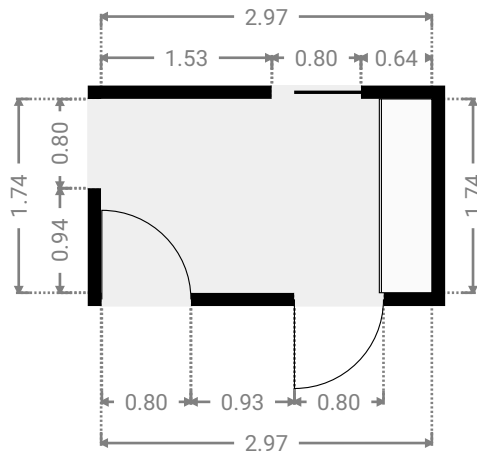
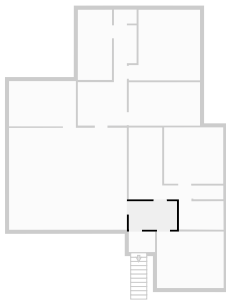

▼ **Hall**
1st Floor

WIDTH: 1.41 m • LENGTH: 3.39 m
AREA: 4.12 m² • PERIMETER: 9.59 m

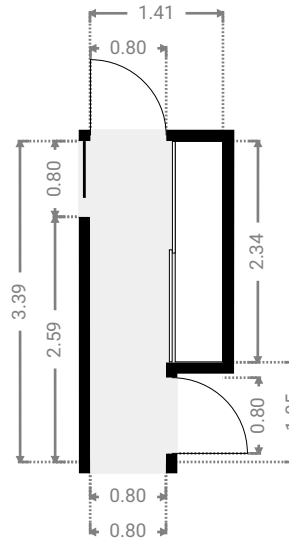
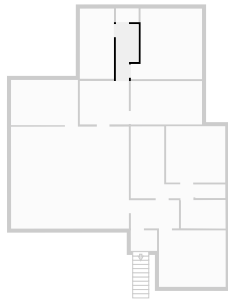

▼ **Kitchen**
1st Floor

WIDTH: 7.28 m • LENGTH: 6.30 m
AREA: 45.84 m² • PERIMETER: 27.15 m

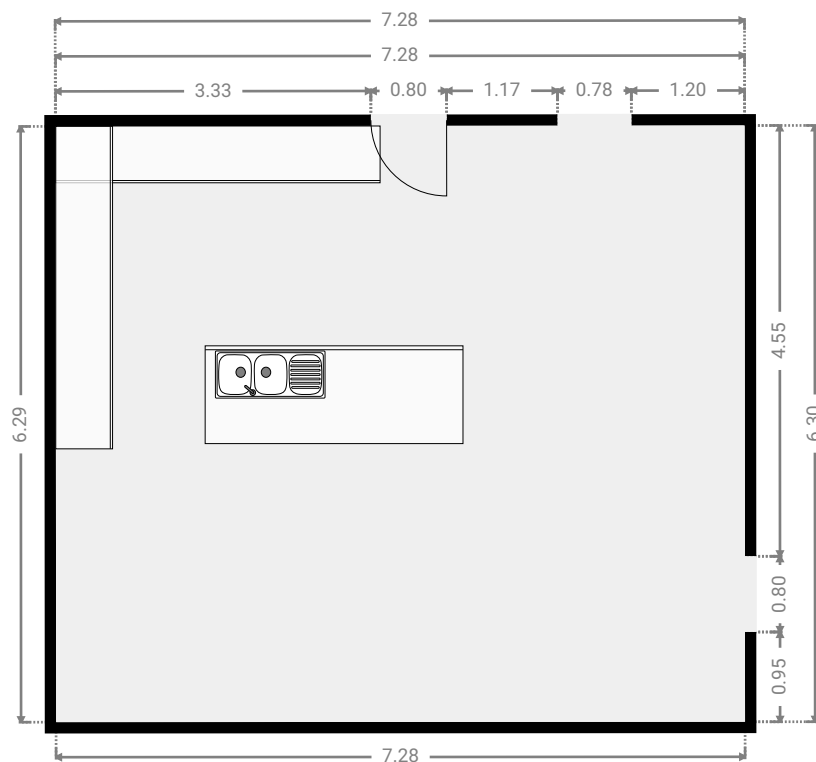
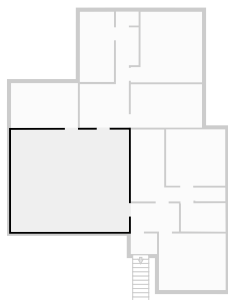

▼ Other
1st Floor

WIDTH: 1.62 m • LENGTH: 1.27 m
AREA: 2.06 m² • PERIMETER: 5.78 m

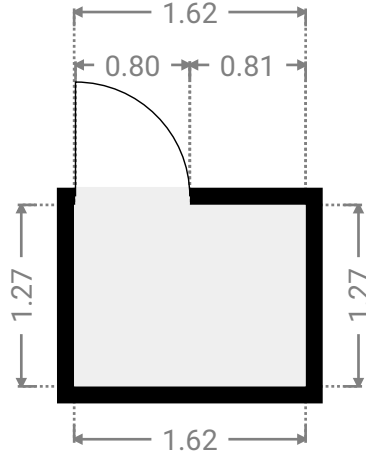
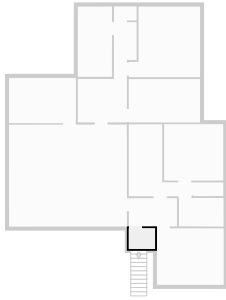

▼ Other
1st Floor

WIDTH: 4.13 m • LENGTH: 2.80 m
AREA: 11.56 m² • PERIMETER: 13.86 m

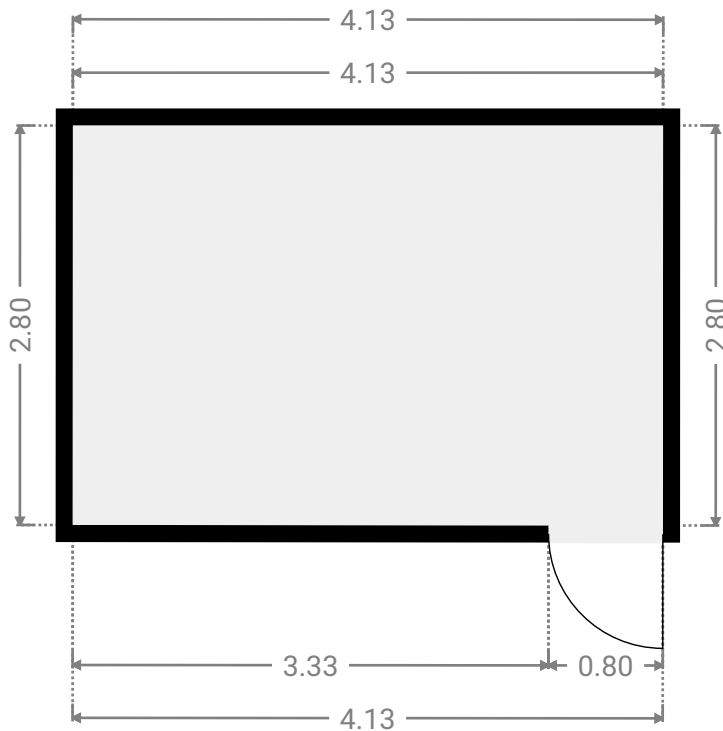
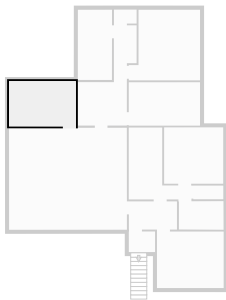

▼ **Stairway**
1st Floor

WIDTH: 3.03 m • LENGTH: 2.68 m
AREA: 8.13 m² • PERIMETER: 11.42 m

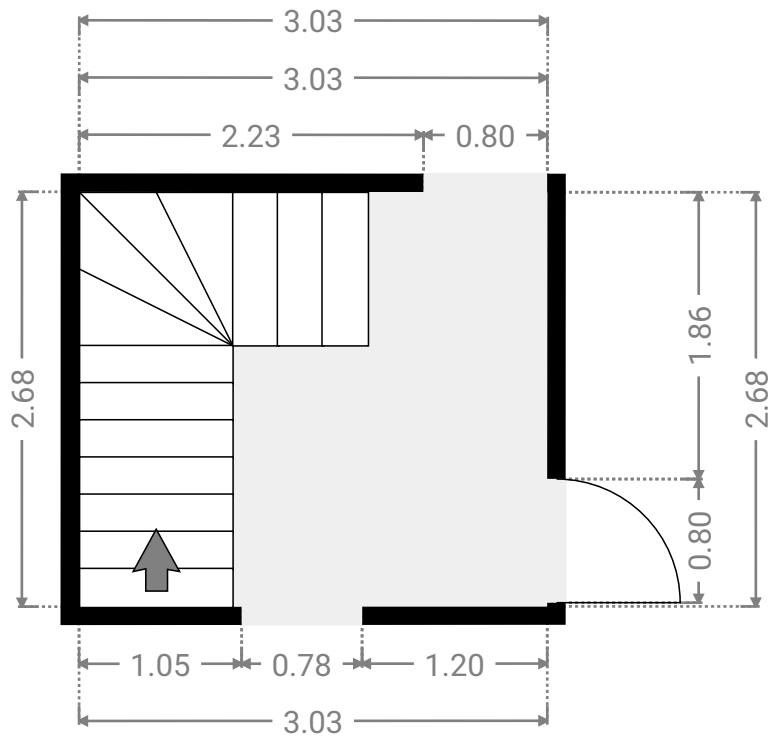
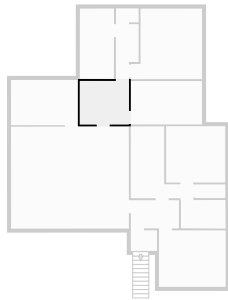

▼ **Toilet**
1st Floor

WIDTH: 1.85 m • LENGTH: 0.84 m
AREA: 1.56 m² • PERIMETER: 5.39 m

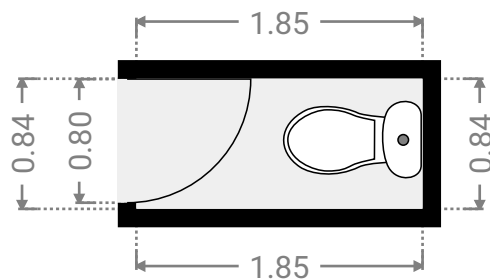
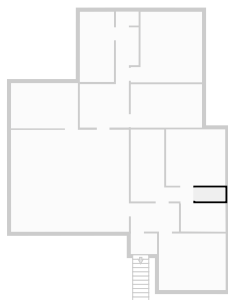

▼ Toilet
1st Floor

WIDTH: 1.40 m • LENGTH: 0.86 m
AREA: 1.20 m² • PERIMETER: 4.52 m

