

251 Noel Street

SUBMITTED BY

Ray White Rockhampton Casey
stockers@cqoz.com

CREATED ON

2022-04-12

Floors

2

▼ Ground Floor

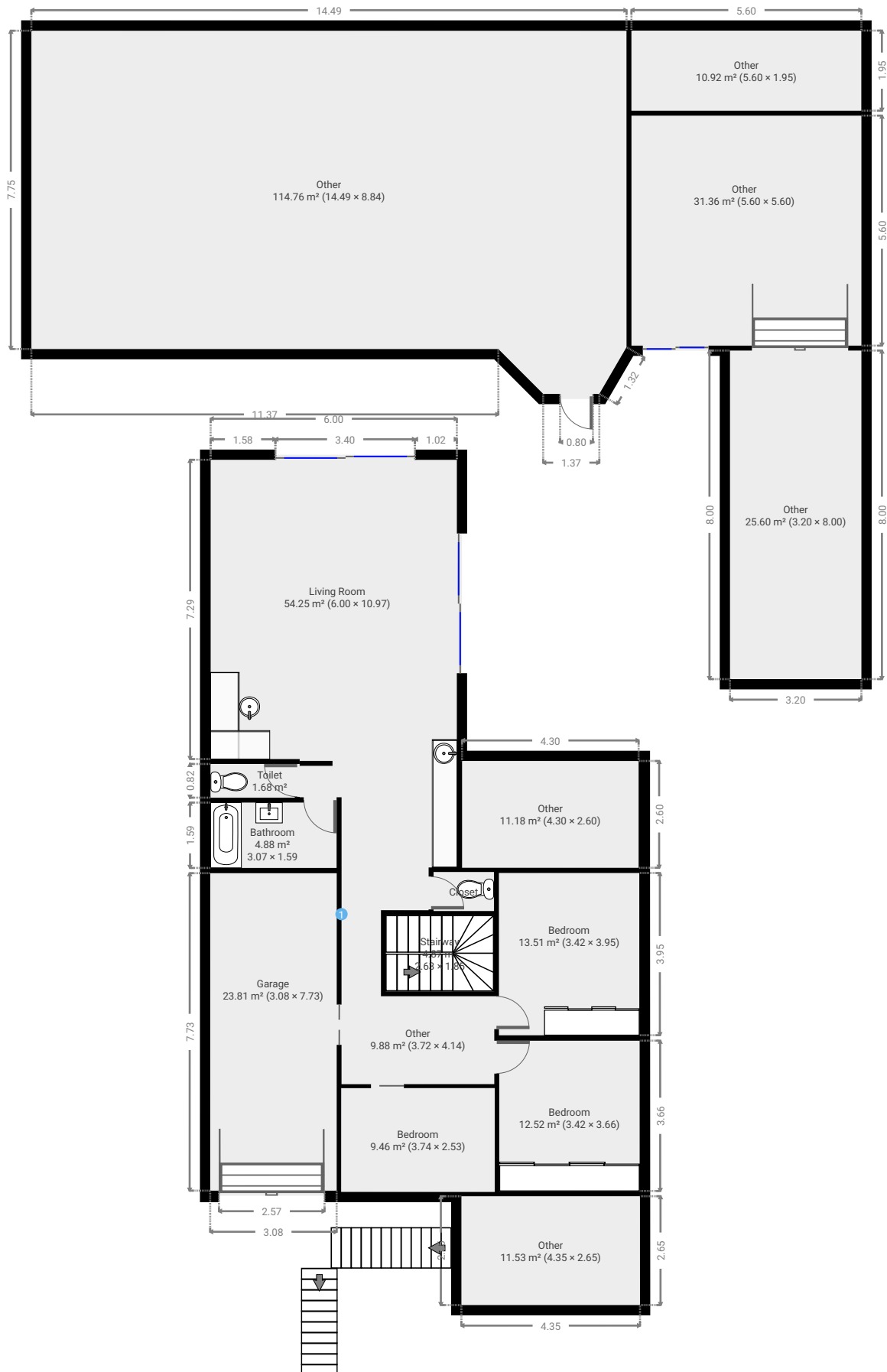

▼ **Bedroom**
Ground Floor

WIDTH: 3.42 m • LENGTH: 3.66 m
AREA: 12.52 m² • PERIMETER: 14.16 m

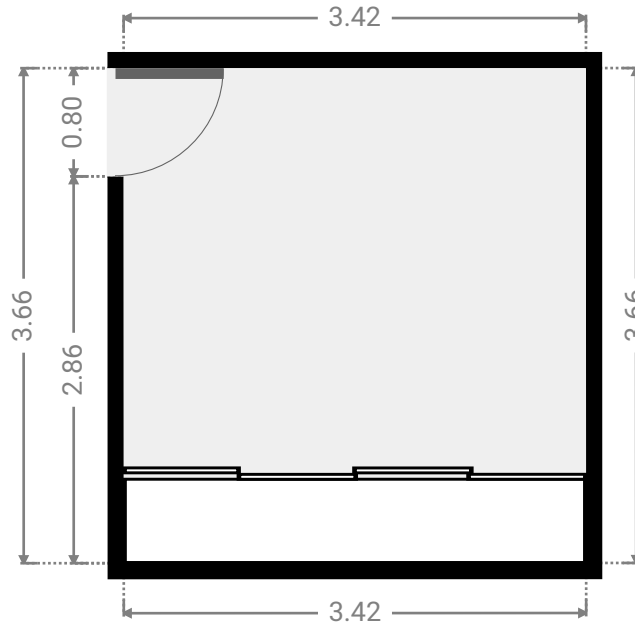
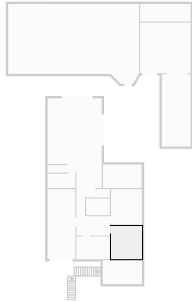

▼ **Other**
Ground Floor

WIDTH: 3.72 m • LENGTH: 4.14 m
AREA: 9.88 m² • PERIMETER: 15.72 m

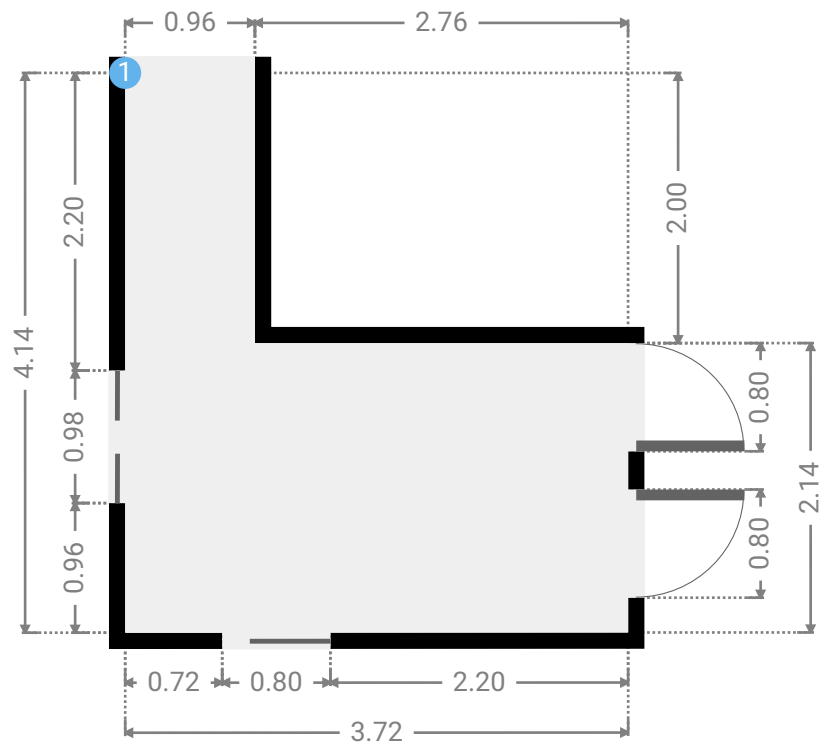
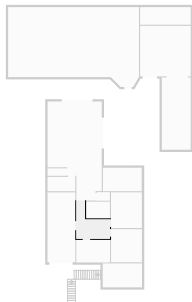

▼ Other/Ground Floor

1 OPENING

Height
0.00 m



▼ **Bedroom**
Ground Floor

WIDTH: 3.42 m • LENGTH: 3.95 m
AREA: 13.51 m² • PERIMETER: 14.74 m

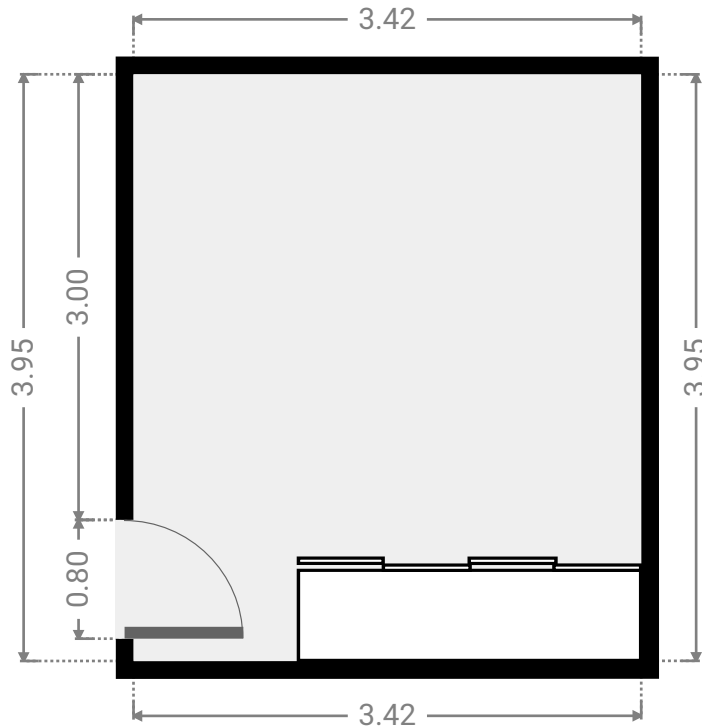
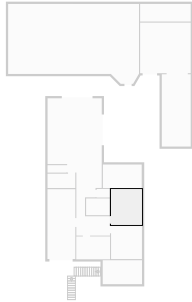

▼ **Bedroom**
Ground Floor

WIDTH: 3.74 m • LENGTH: 2.53 m
AREA: 9.46 m² • PERIMETER: 12.54 m

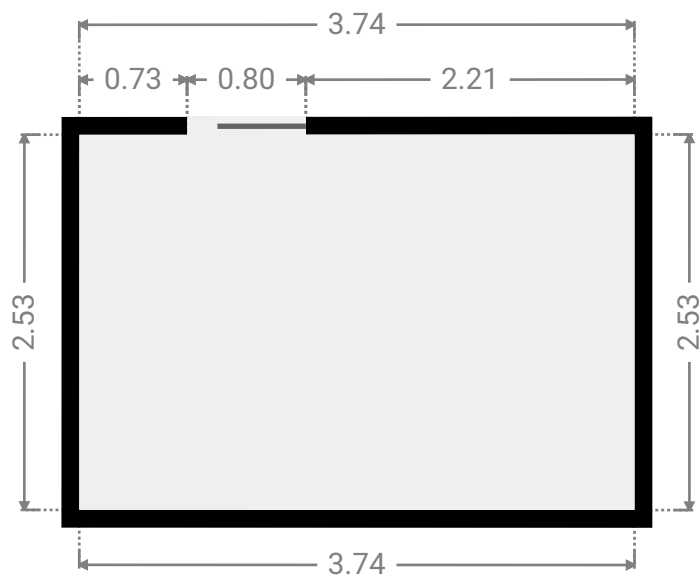
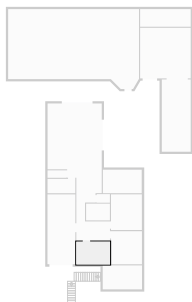

▼ **Garage**
Ground Floor

WIDTH: 3.08 m • LENGTH: 7.73 m
AREA: 23.81 m² • PERIMETER: 21.62 m

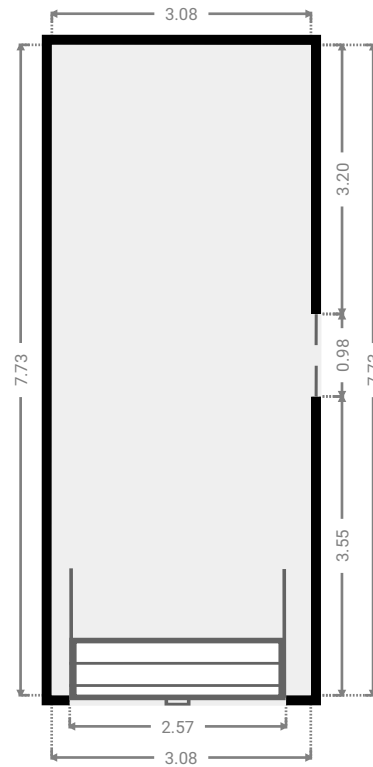
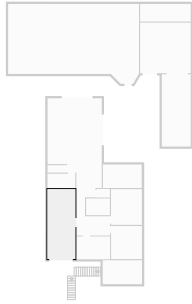

▼ **Stairway**
Ground Floor

WIDTH: 2.63 m • LENGTH: 1.85 m
AREA: 4.87 m² • PERIMETER: 8.97 m

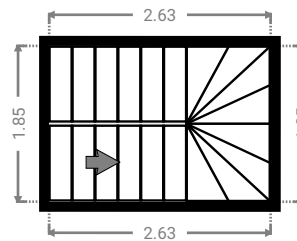
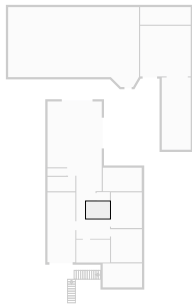

▼ **Closet**
Ground Floor

WIDTH: 1.47 m • LENGTH: 0.95 m
AREA: 1.40 m² • PERIMETER: 4.84 m

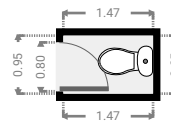
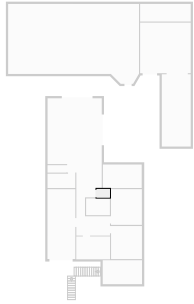

▼ **Living Room**
Ground Floor

WIDTH: 6.00 m • LENGTH: 10.97 m
AREA: 54.25 m² • PERIMETER: 33.92 m

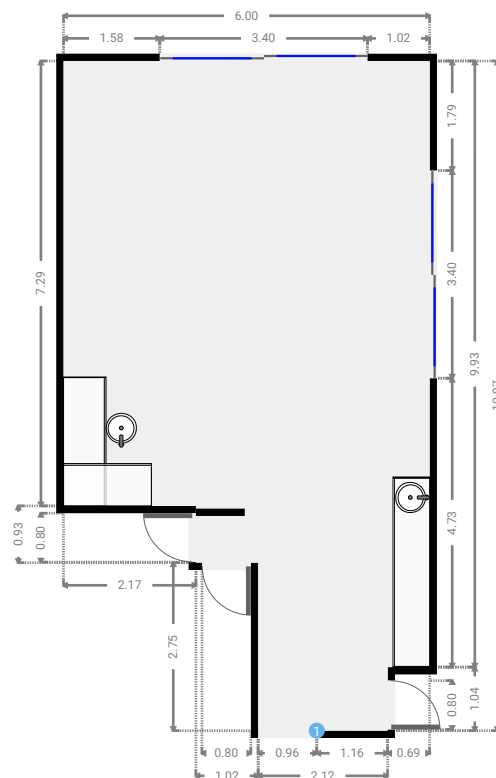
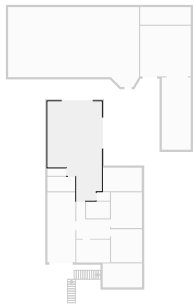

▼ **Bathroom**
Ground Floor

WIDTH: 3.07 m • LENGTH: 1.59 m
AREA: 4.88 m² • PERIMETER: 9.32 m

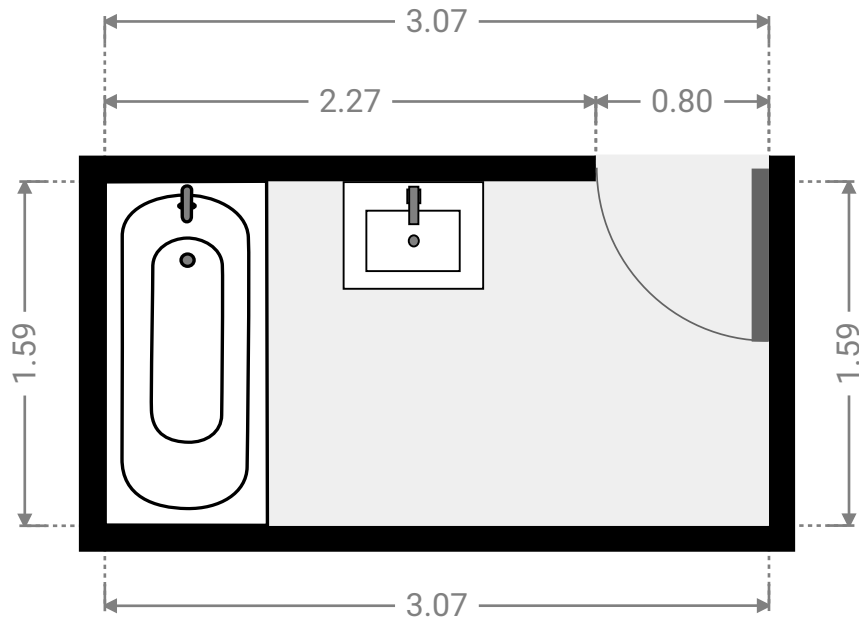
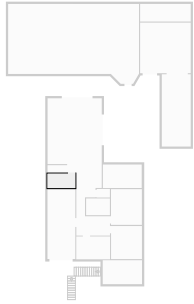

▼ **Toilet**
Ground Floor

WIDTH: 2.05 m • LENGTH: 0.82 m
AREA: 1.68 m² • PERIMETER: 5.74 m

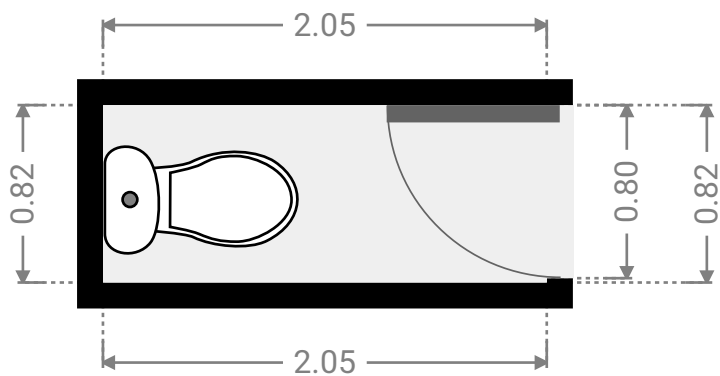
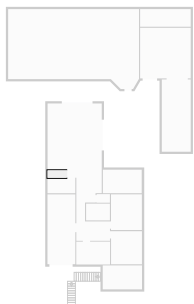

▼ Other
Ground Floor

WIDTH: 4.30 m • LENGTH: 2.60 m
AREA: 11.18 m² • PERIMETER: 13.80 m

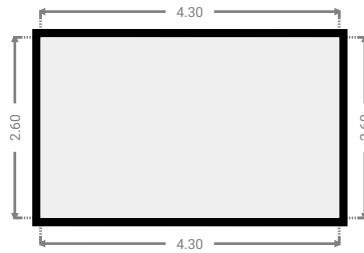
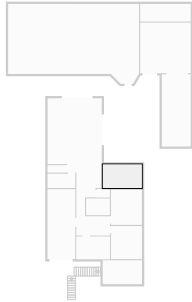

▼ Other
Ground Floor

WIDTH: 3.20 m • LENGTH: 8.00 m
AREA: 25.60 m² • PERIMETER: 22.40 m

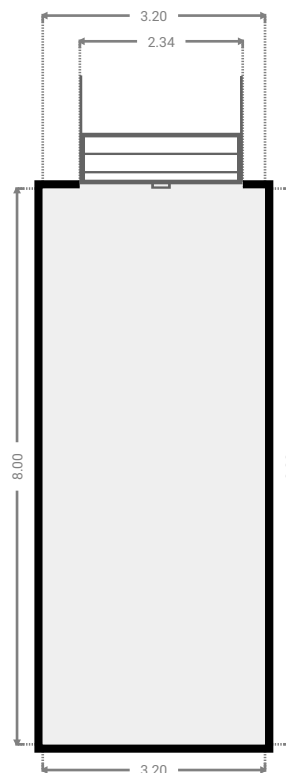
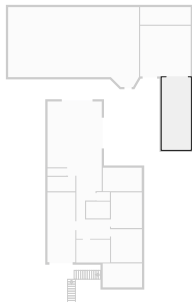

▼ Other
Ground Floor

WIDTH: 5.60 m • LENGTH: 5.60 m
AREA: 31.36 m² • PERIMETER: 22.40 m

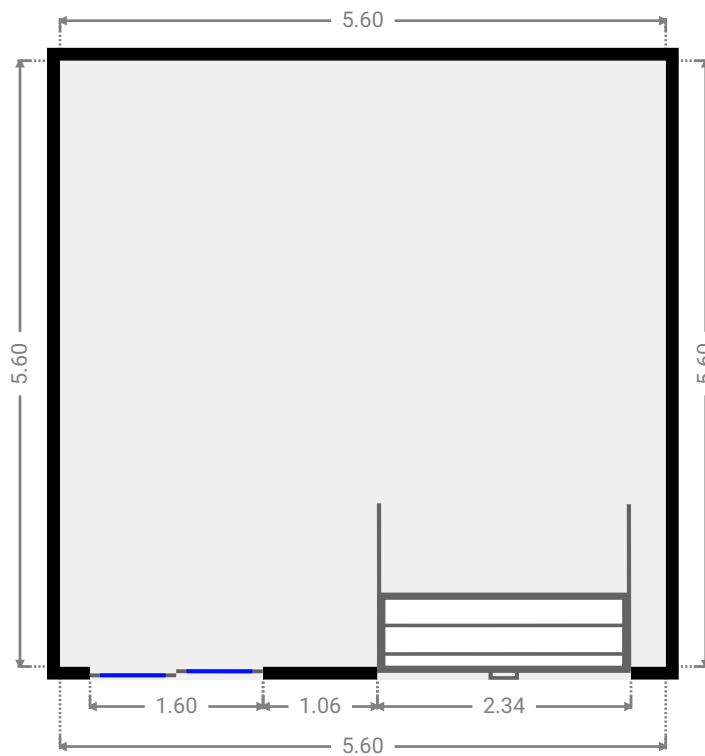
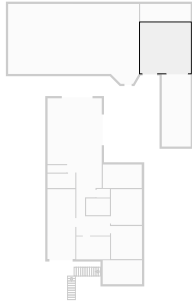

▼ Other
Ground Floor

WIDTH: 5.60 m • LENGTH: 1.95 m
AREA: 10.92 m² • PERIMETER: 15.10 m

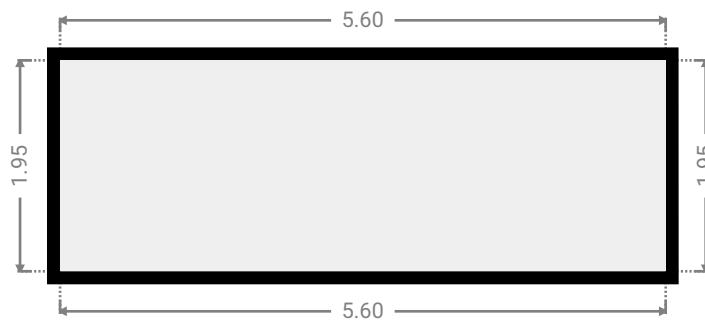
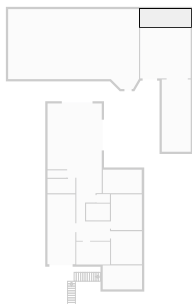

▼ **Other**
Ground Floor

WIDTH: 14.49 m • LENGTH: 8.84 m
AREA: 114.76 m² • PERIMETER: 45.55 m

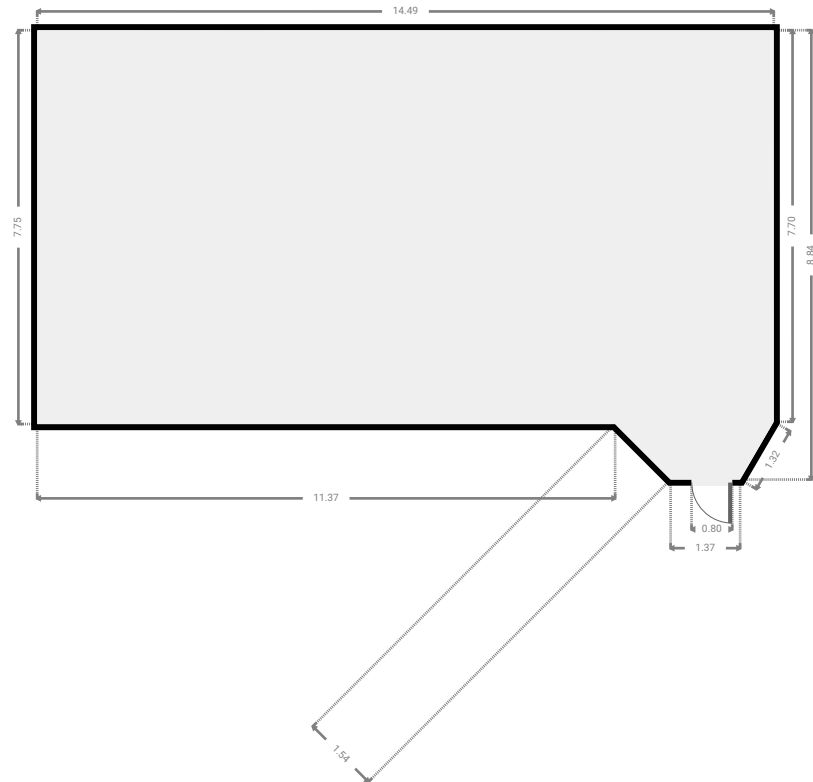
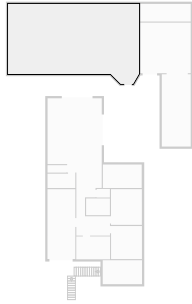

▼ **Other**
Ground Floor

WIDTH: 4.35 m • LENGTH: 2.65 m
AREA: 11.53 m² • PERIMETER: 14.00 m

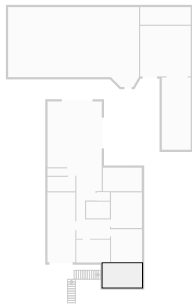

▼ 1st Floor



▼ Living Room
1st Floor

WIDTH: 4.17 m • LENGTH: 3.72 m
AREA: 15.51 m² • PERIMETER: 15.78 m

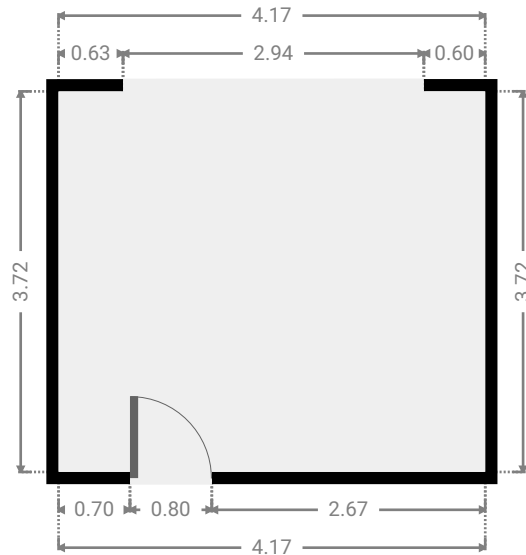

▼ Stairway
1st Floor

WIDTH: 7.76 m • LENGTH: 3.90 m
AREA: 26.48 m² • PERIMETER: 23.32 m

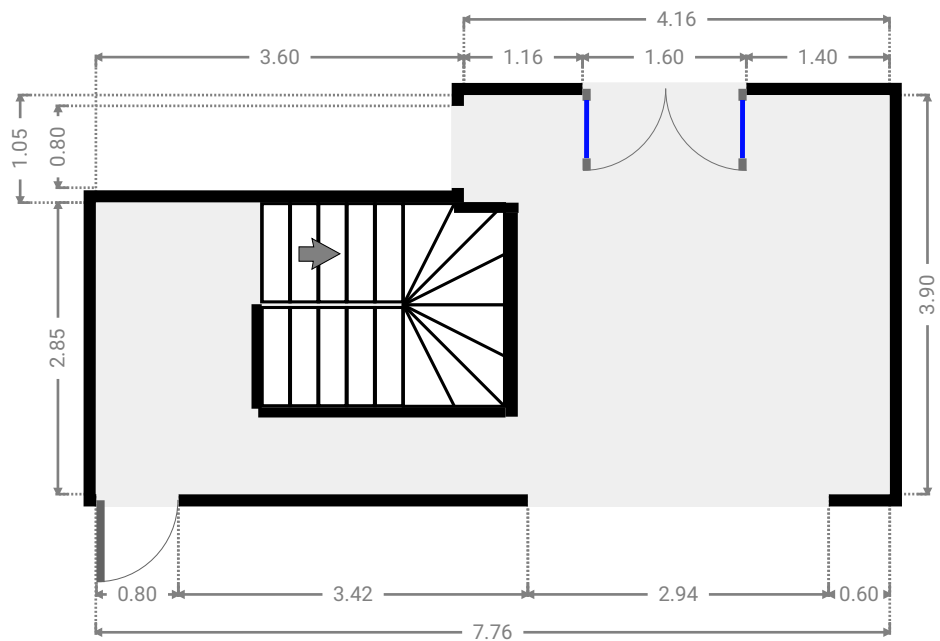
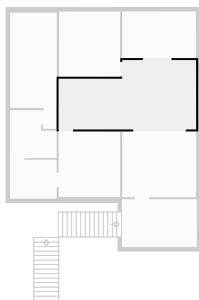

▼ **Kitchen**
1st Floor

WIDTH: 3.44 m • LENGTH: 3.70 m
AREA: 12.72 m² • PERIMETER: 14.28 m

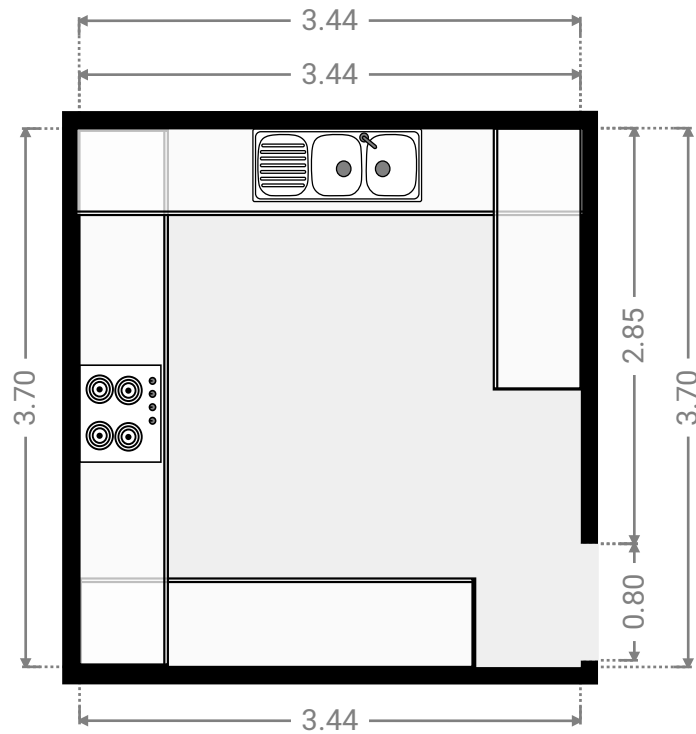
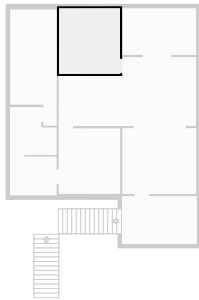

▼ **Other**
1st Floor

WIDTH: 4.17 m • LENGTH: 2.63 m
AREA: 10.99 m² • PERIMETER: 13.61 m

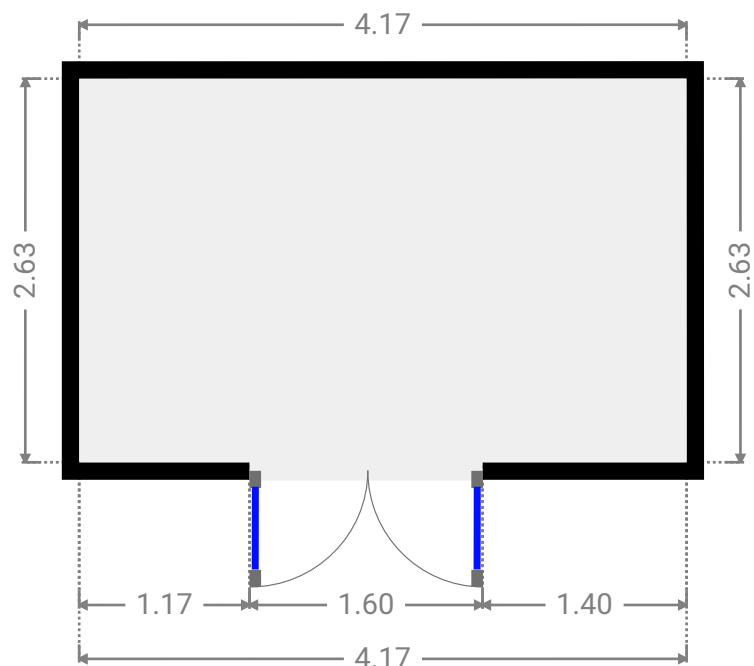

▼ Bedroom
1st Floor

WIDTH: 3.47 m • LENGTH: 3.71 m
AREA: 12.85 m² • PERIMETER: 14.35 m

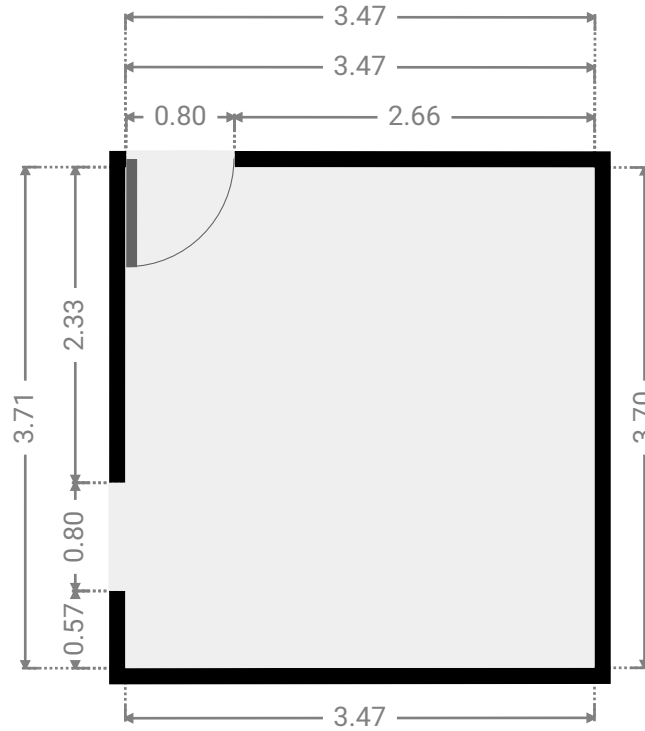
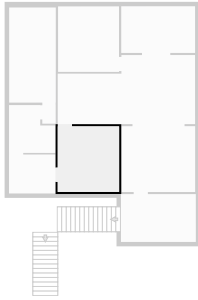

▼ Closet
1st Floor

WIDTH: 2.63 m • LENGTH: 2.20 m
AREA: 5.78 m² • PERIMETER: 9.66 m

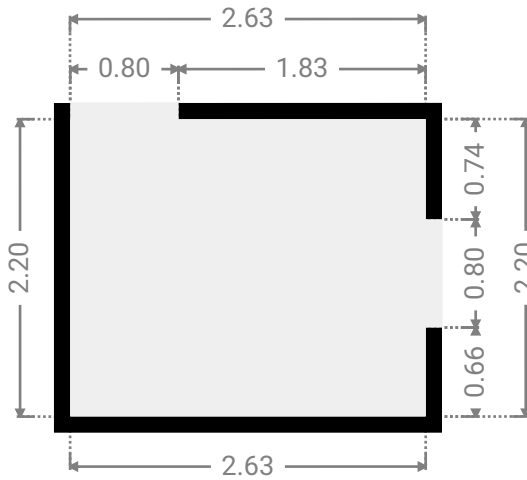
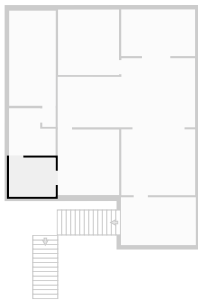

▼ **Bathroom**
1st Floor

WIDTH: 2.63 m • LENGTH: 2.70 m
AREA: 6.10 m² • PERIMETER: 10.66 m

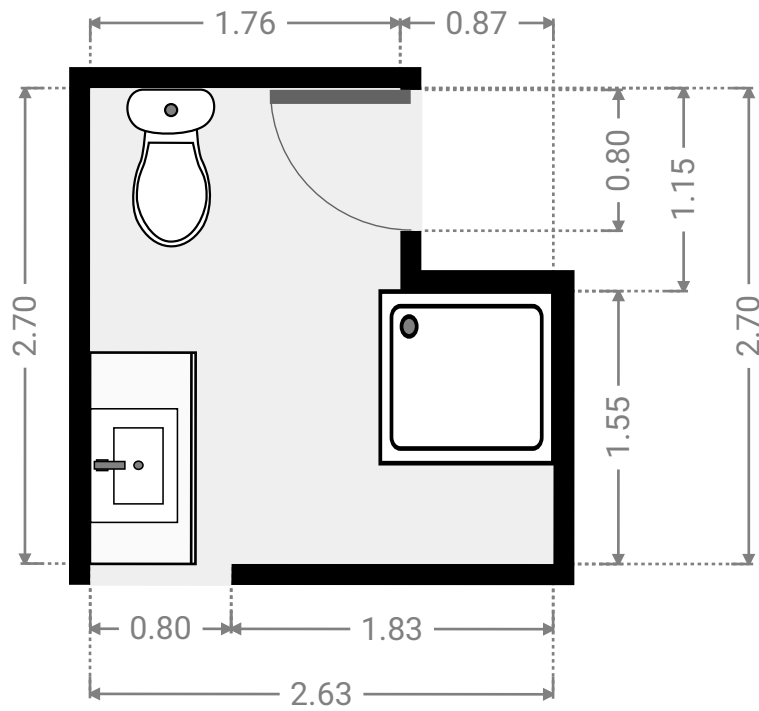

▼ **Hall**
1st Floor

WIDTH: 0.76 m • LENGTH: 1.06 m
AREA: 0.80 m² • PERIMETER: 3.63 m

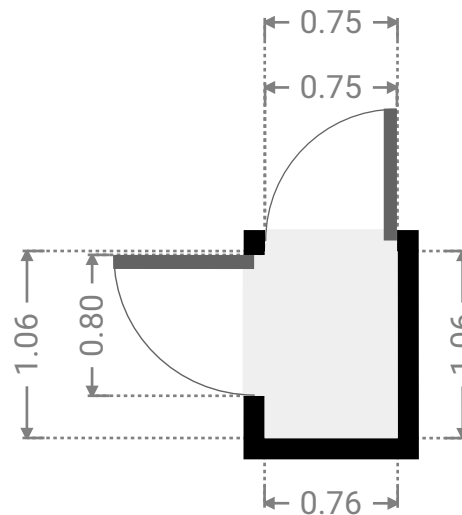

▼ **Living Room**
1st Floor

WIDTH: 2.63 m • LENGTH: 5.37 m
AREA: 14.13 m² • PERIMETER: 16.00 m

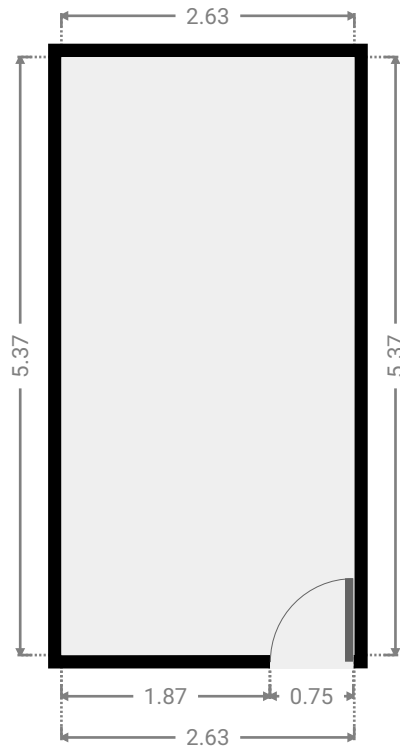
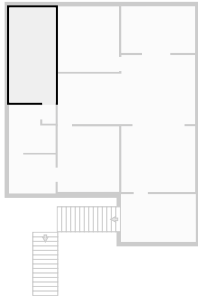

▼ **Other**
1st Floor

WIDTH: 4.23 m • LENGTH: 2.70 m
AREA: 11.42 m² • PERIMETER: 13.86 m

