

# 25 Scott Street

**SUBMITTED BY**  
Ray White Rockhampton Casey  
stockers@cqoz.com

---

**CREATED ON**  
2017-09-26

---

**Floors**  
2

---

▼ Ground Floor

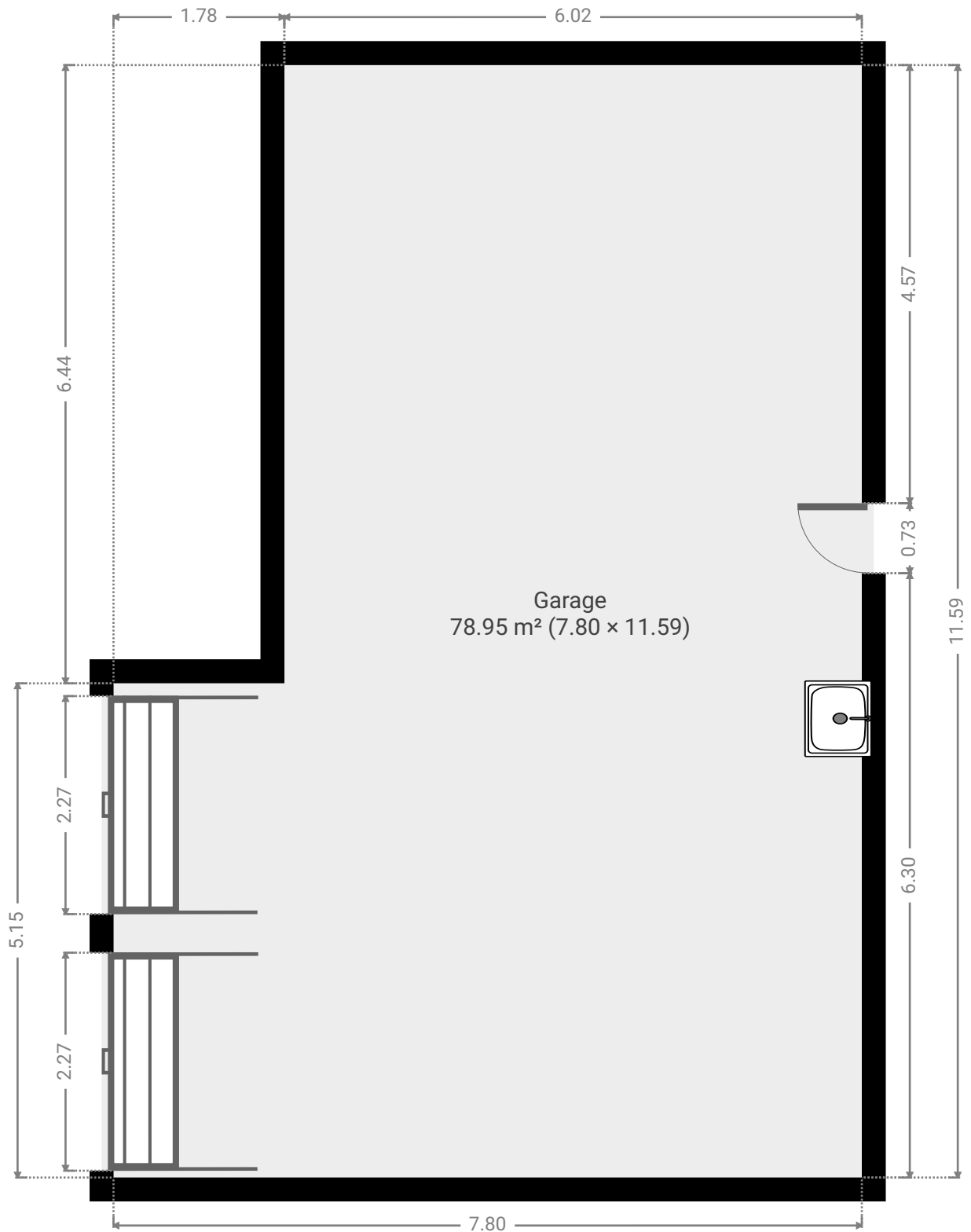

▼ **Garage**  
Ground Floor

WIDTH: 11.59 m • LENGTH: 7.80 m  
AREA: 78.95 m<sup>2</sup> • PERIMETER: 38.79 m

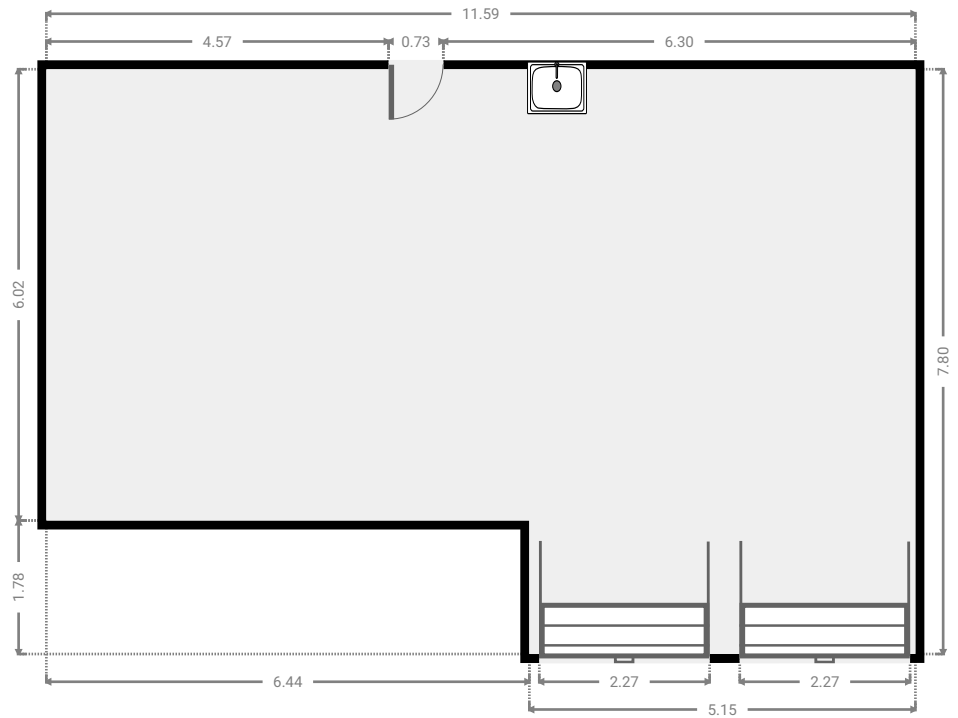
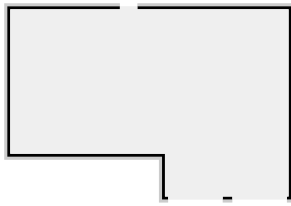

▼ 1st Floor

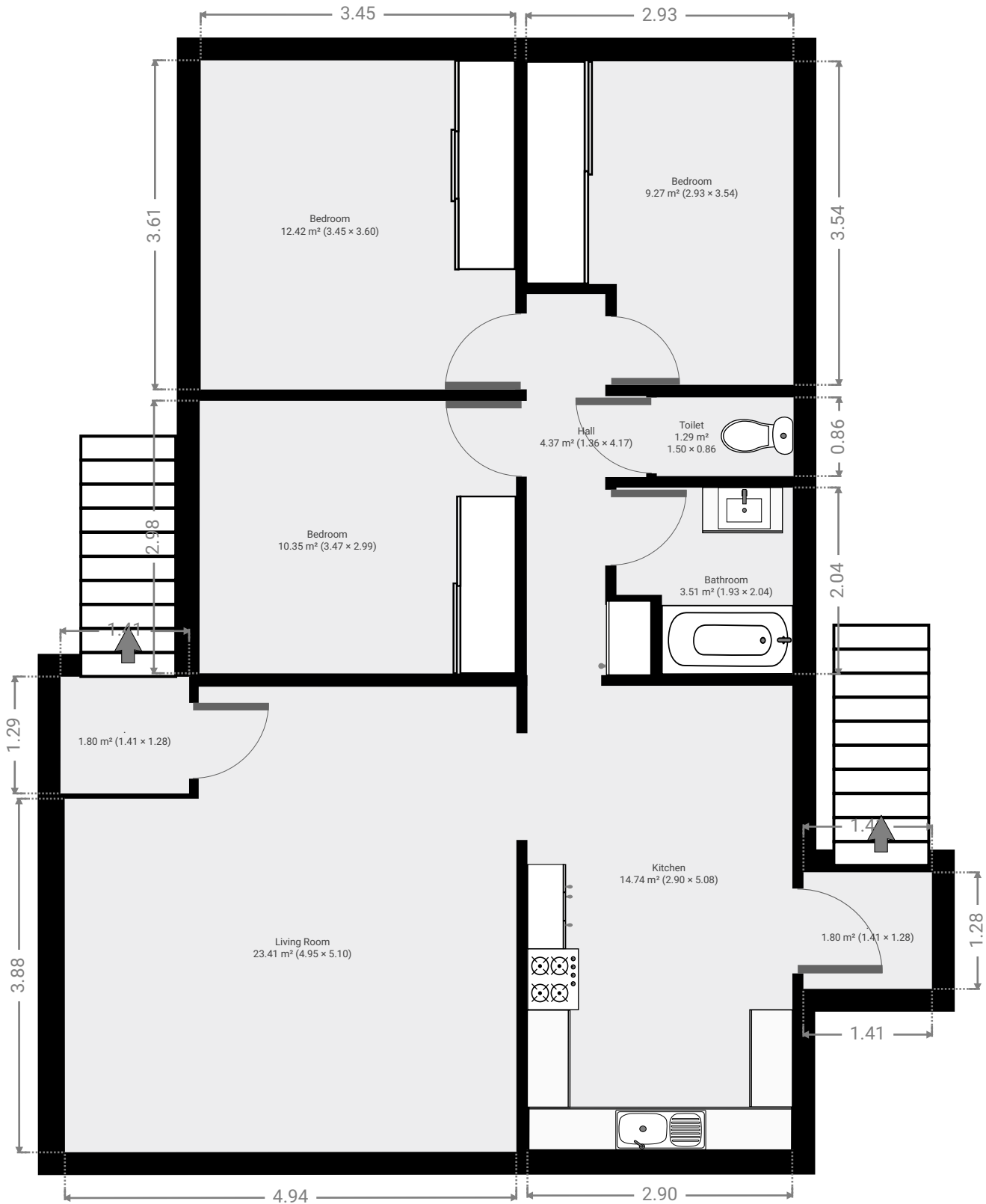

▼ Living Room  
1st Floor

WIDTH: 5.09 m • LENGTH: 4.94 m  
AREA: 23.41 m<sup>2</sup> • PERIMETER: 20.08 m

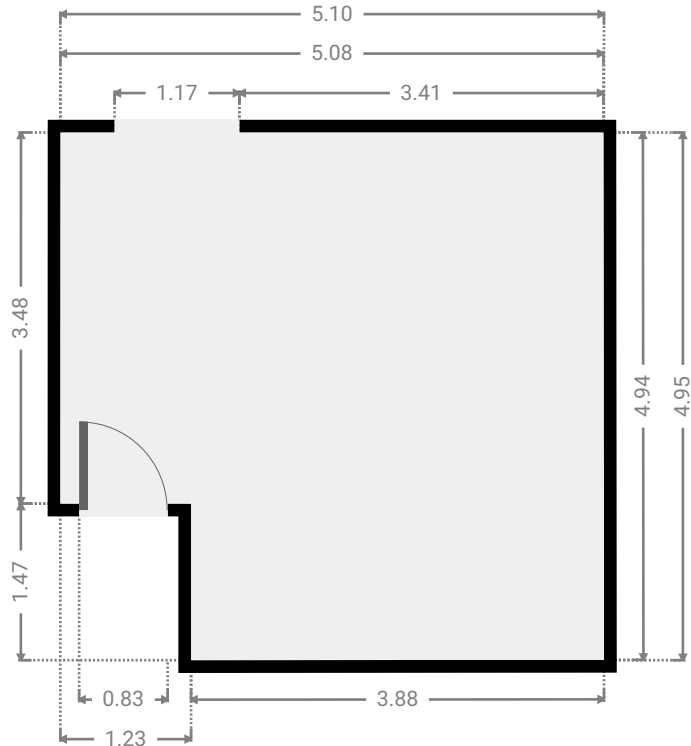
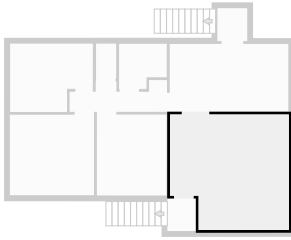

▼ Kitchen  
1st Floor

WIDTH: 5.08 m • LENGTH: 2.90 m  
AREA: 14.74 m<sup>2</sup> • PERIMETER: 15.97 m

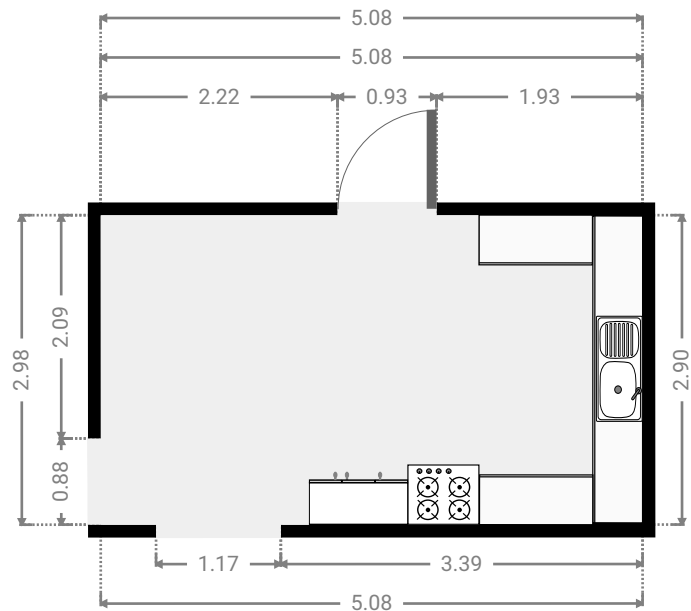
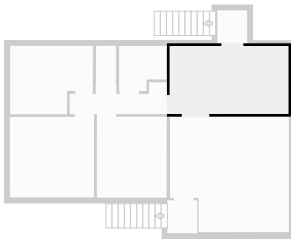

▼ **Hall**  
1st Floor

WIDTH: 4.18 m • LENGTH: 1.36 m  
AREA: 4.37 m<sup>2</sup> • PERIMETER: 11.97 m

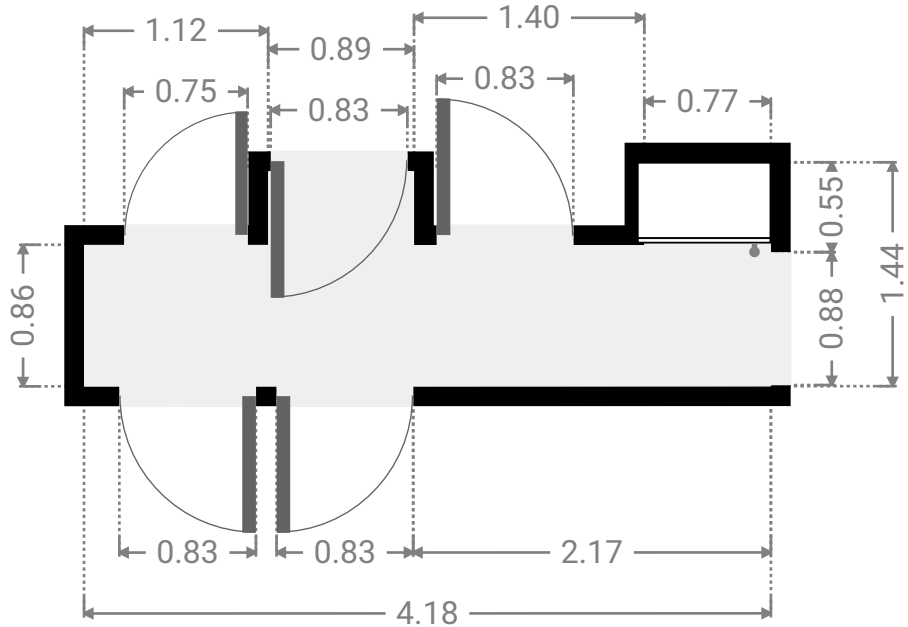
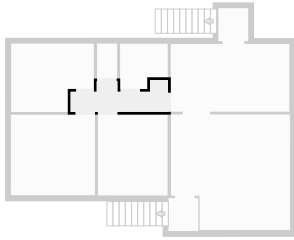

▼ **Bathroom**  
1st Floor

WIDTH: 2.04 m • LENGTH: 1.93 m  
AREA: 3.51 m<sup>2</sup> • PERIMETER: 7.95 m

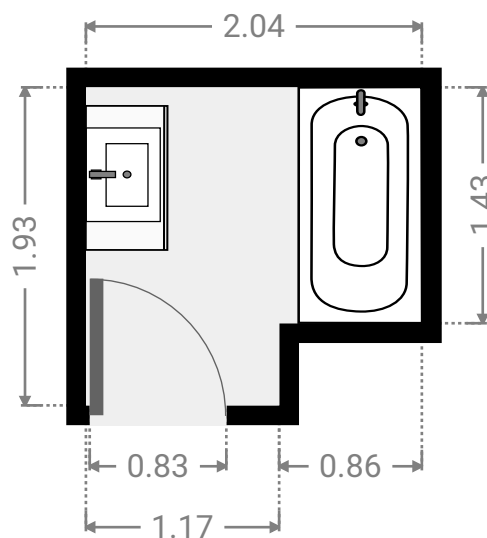
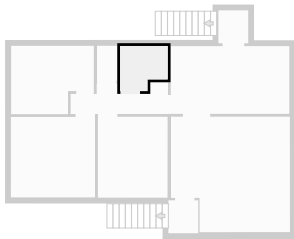

▼ Toilet  
1st Floor

WIDTH: 0.86 m • LENGTH: 1.50 m  
AREA: 1.29 m<sup>2</sup> • PERIMETER: 4.72 m

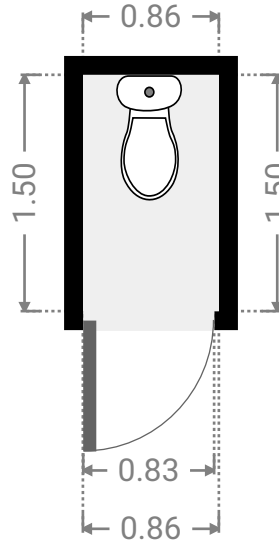
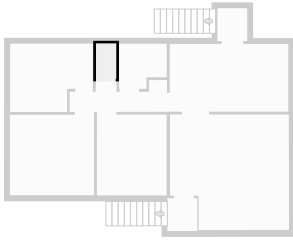

▼ Bedroom  
1st Floor

WIDTH: 3.54 m • LENGTH: 2.93 m  
AREA: 9.27 m<sup>2</sup> • PERIMETER: 12.94 m

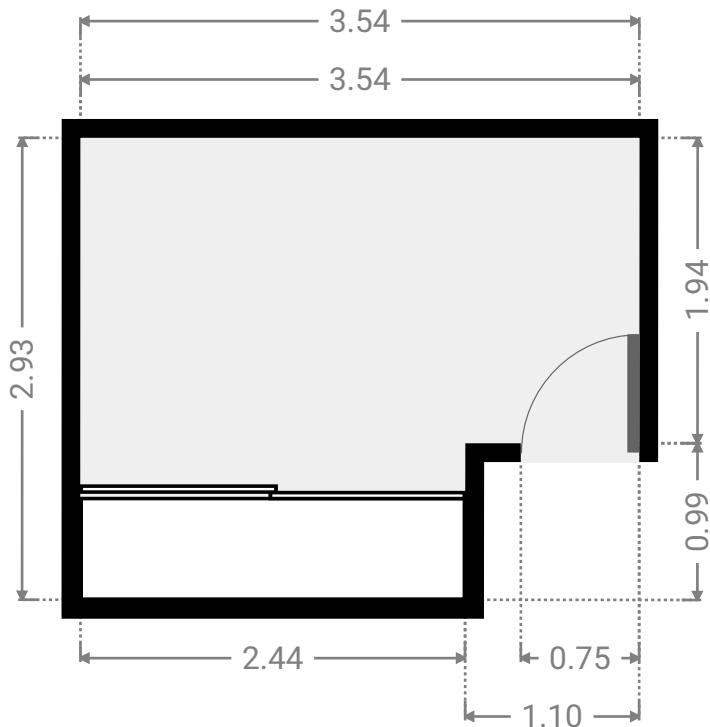
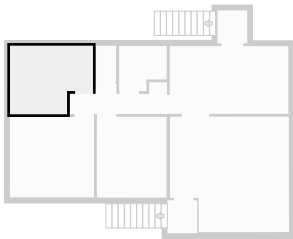

▼ **Bedroom**  
1st Floor

WIDTH: 3.60 m • LENGTH: 3.45 m  
AREA: 12.42 m<sup>2</sup> • PERIMETER: 14.10 m

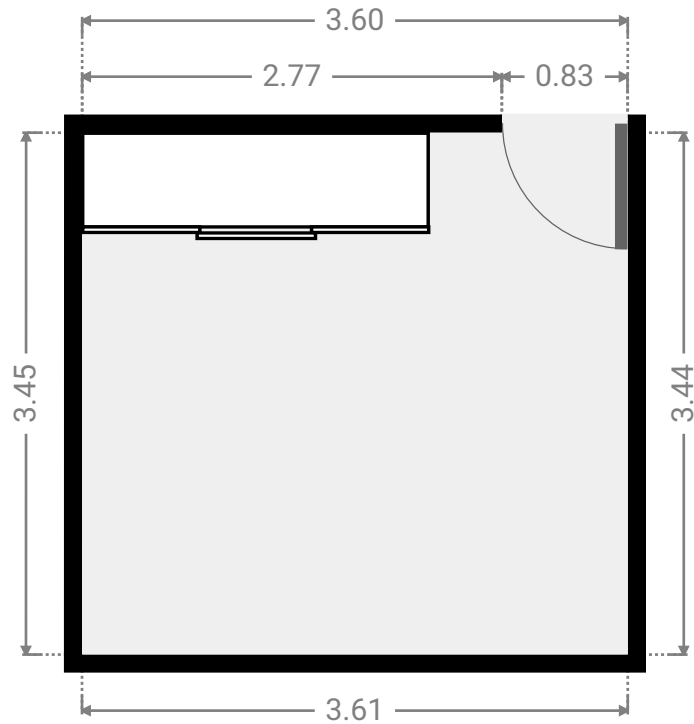
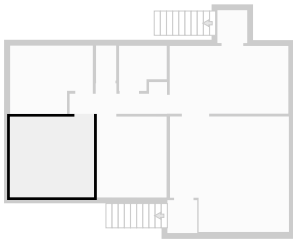

▼ **Bedroom**  
1st Floor

WIDTH: 2.99 m • LENGTH: 3.47 m  
AREA: 10.35 m<sup>2</sup> • PERIMETER: 12.90 m

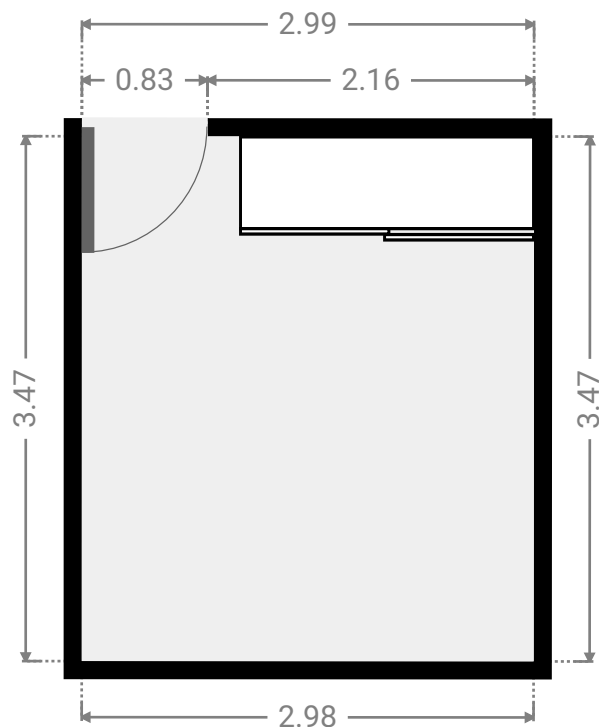
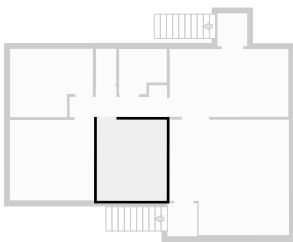



▼ .  
1st Floor

WIDTH: 1.28 m • LENGTH: 1.41 m  
AREA: 1.80 m<sup>2</sup> • PERIMETER: 5.38 m

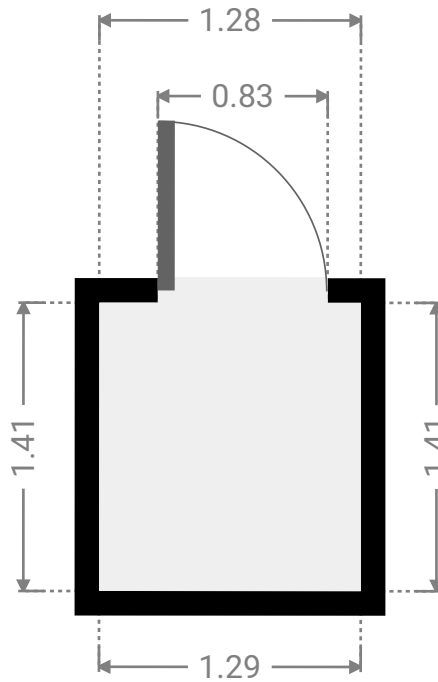
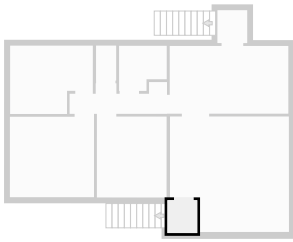

▼ .  
1st Floor

WIDTH: 1.28 m • LENGTH: 1.41 m  
AREA: 1.80 m<sup>2</sup> • PERIMETER: 5.37 m

