

25 Peltophorum Street

SUBMITTED BY

Ray White Rockhampton Casey
stockers@cqoz.com

CREATED ON

2021-12-13

Floors

2

▼ Ground Floor

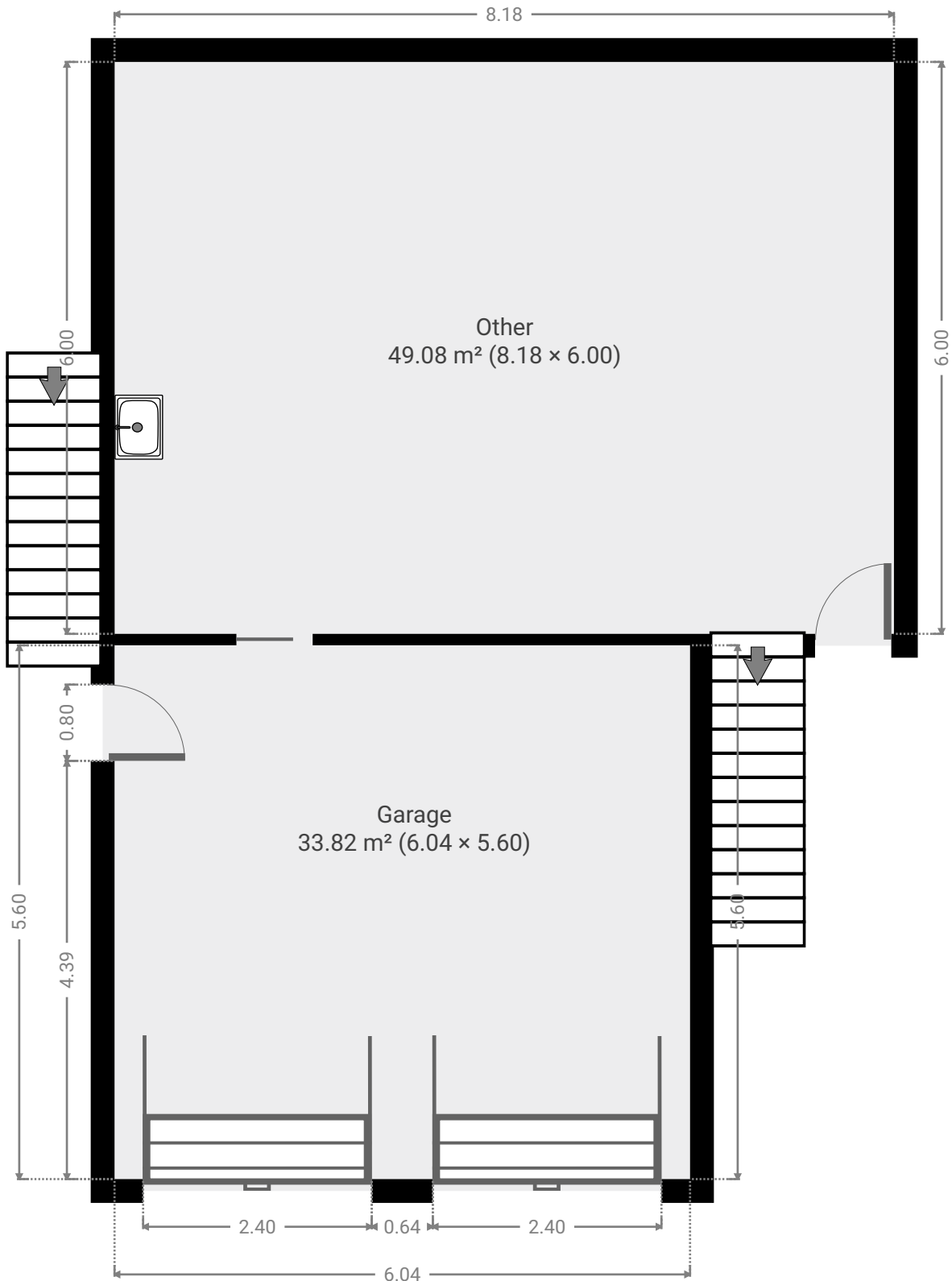

▼ **Garage**
Ground Floor

WIDTH: 6.04 m • LENGTH: 5.60 m
AREA: 33.82 m² • PERIMETER: 23.28 m

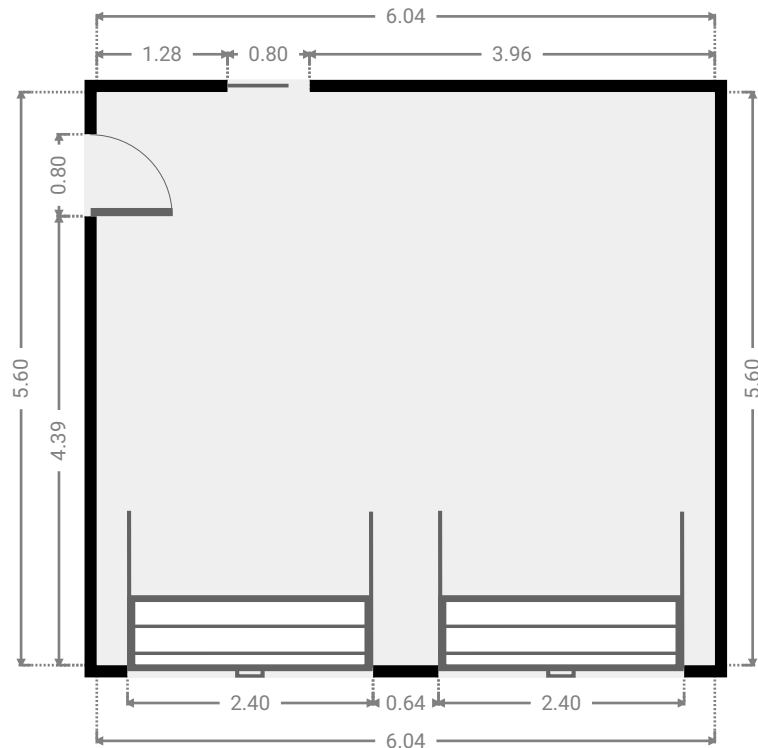
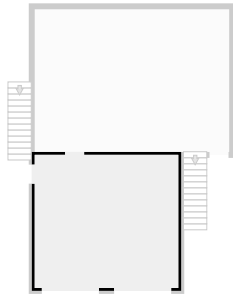

▼ **Other**
Ground Floor

WIDTH: 8.18 m • LENGTH: 6.00 m
AREA: 49.08 m² • PERIMETER: 28.36 m

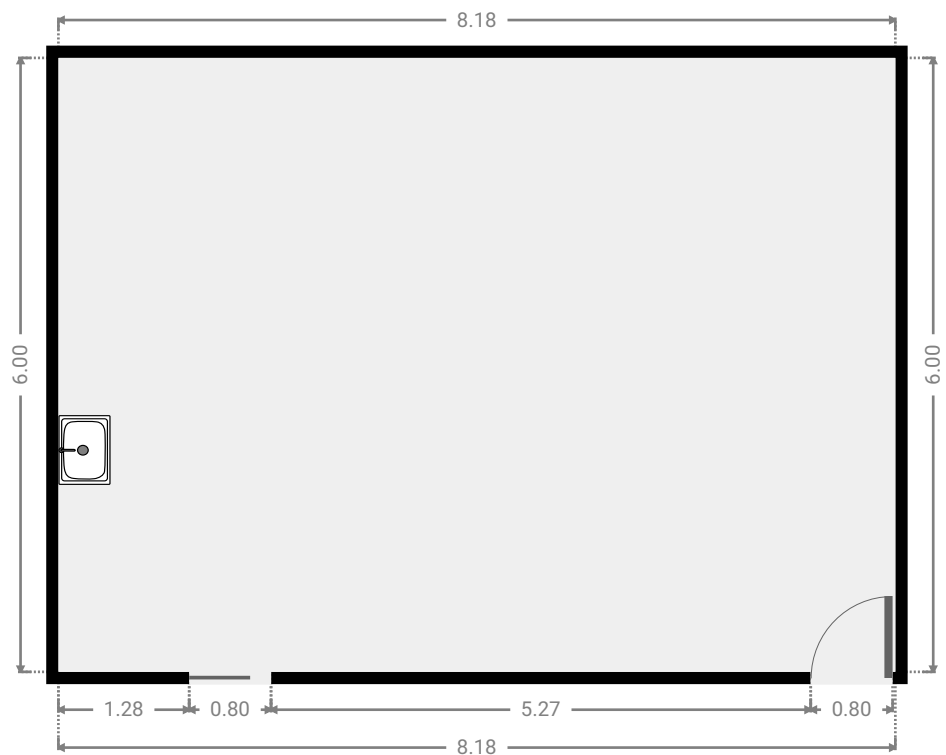
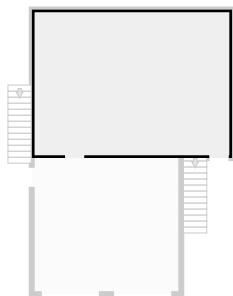

▼ 1st Floor

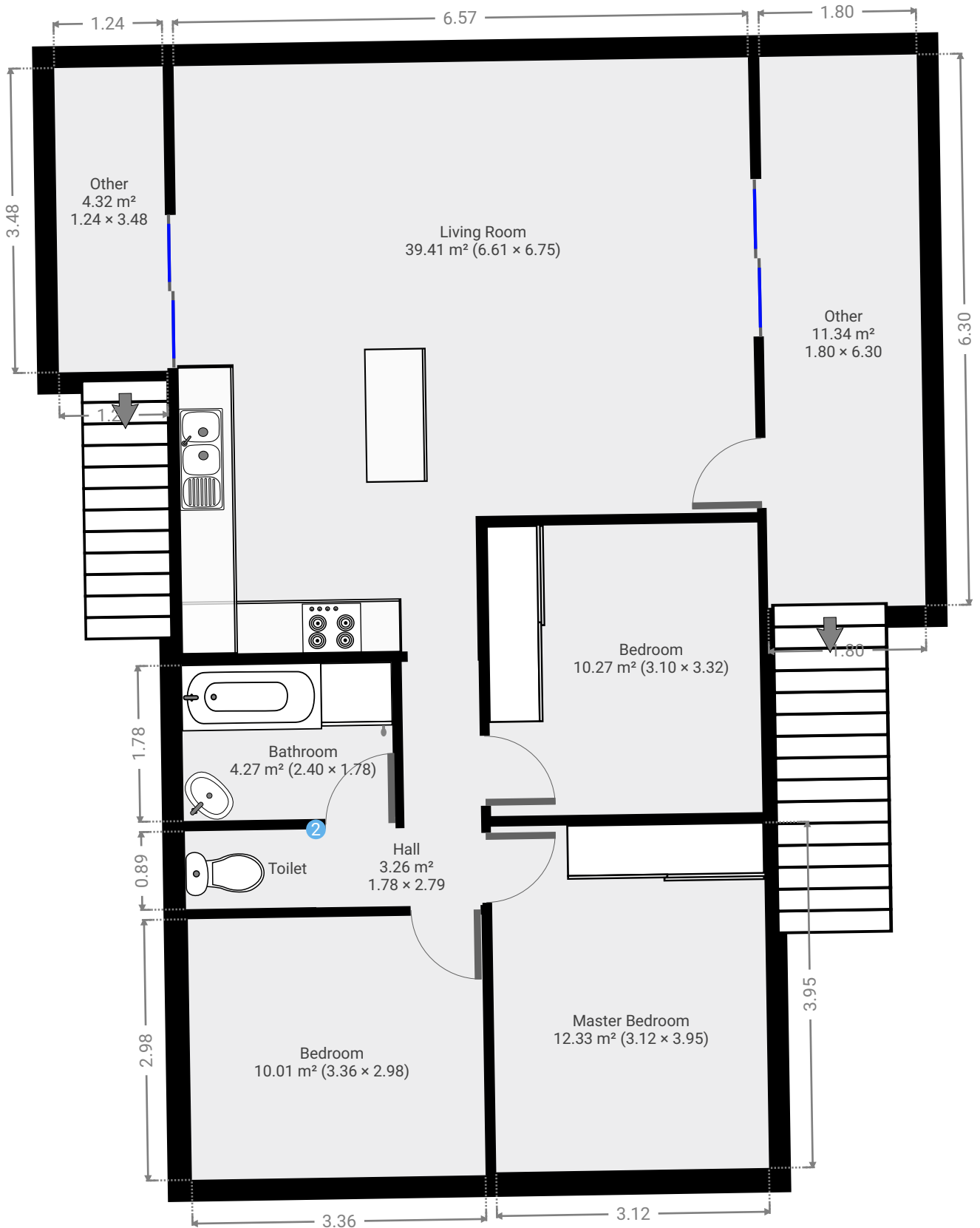

▼ **Living Room**
1st Floor

WIDTH: 6.61 m • LENGTH: 6.75 m
AREA: 39.41 m² • PERIMETER: 26.64 m

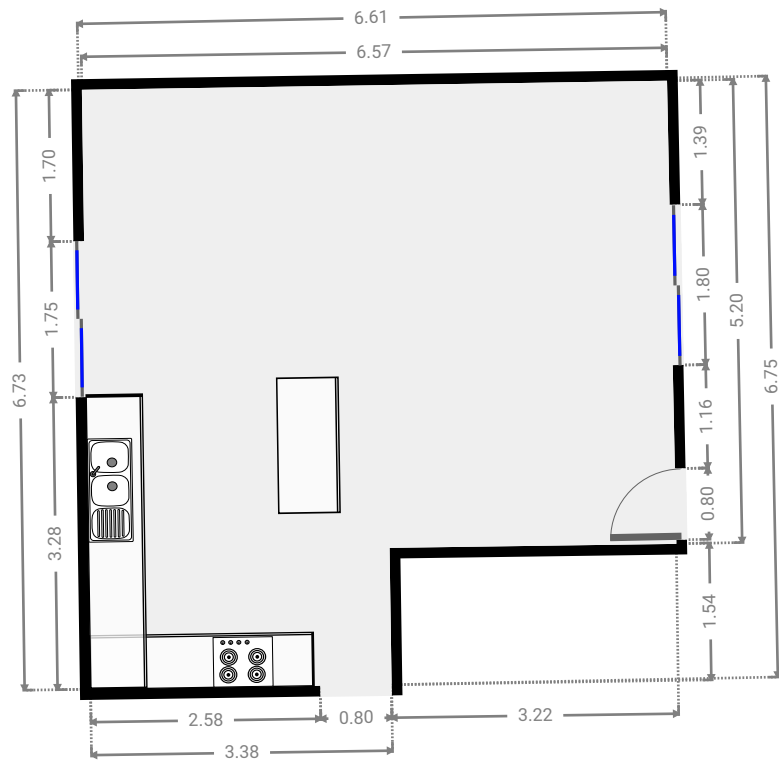
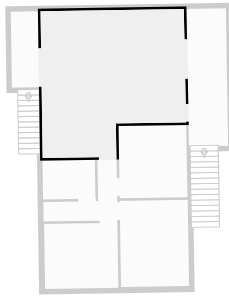

▼ **Hall**
1st Floor

WIDTH: 1.78 m • LENGTH: 2.79 m
AREA: 3.26 m² • PERIMETER: 9.14 m

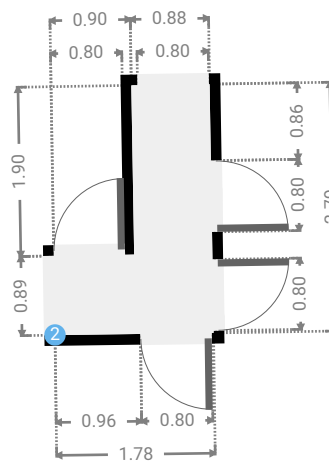
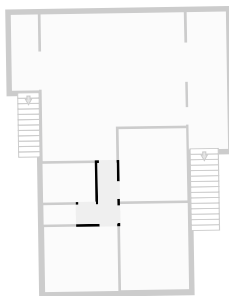

▼ **Toilet**
1st Floor

WIDTH: 1.50 m • LENGTH: 0.89 m
AREA: 1.33 m² • PERIMETER: 4.78 m

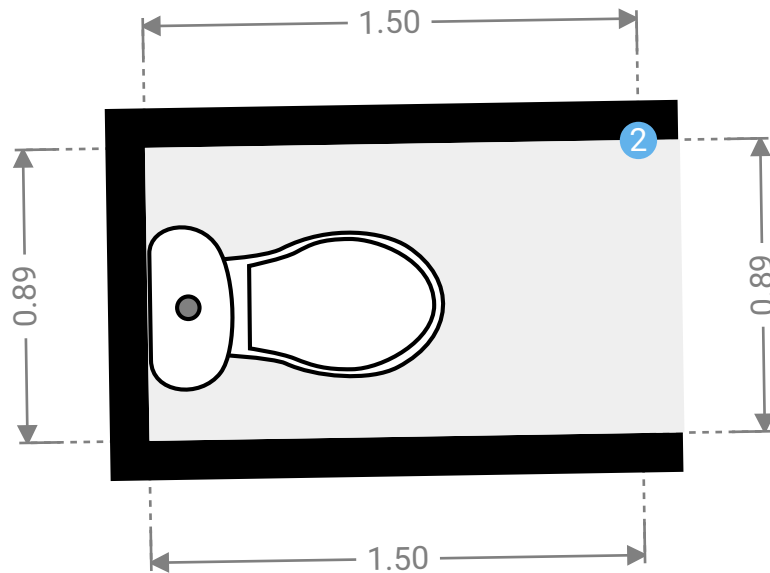
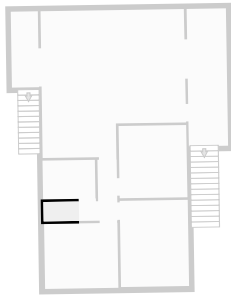

▼ **Toilet/1st Floor**

2 OPENING

Height
0.00 m



▼ **Bathroom**
1st Floor

WIDTH: 2.40 m • LENGTH: 1.78 m
AREA: 4.27 m² • PERIMETER: 8.36 m

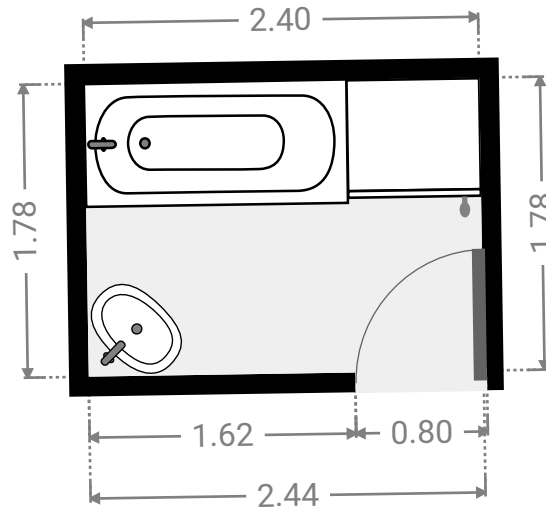
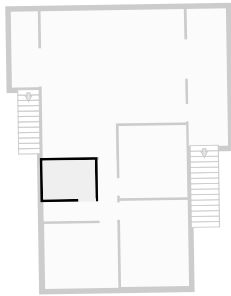

▼ **Bedroom**
1st Floor

WIDTH: 3.36 m • LENGTH: 2.98 m
AREA: 10.01 m² • PERIMETER: 12.68 m

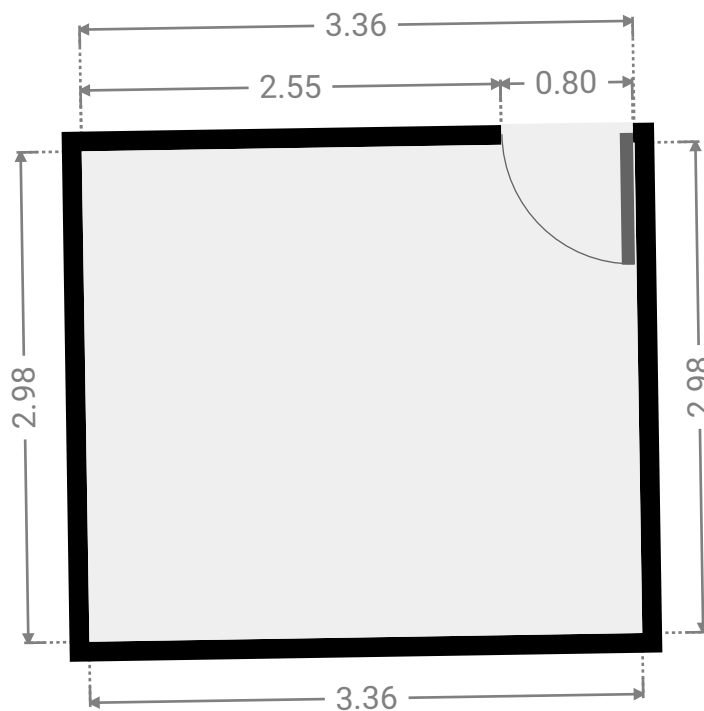
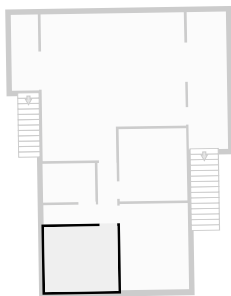

▼ **Master Bedroom**
1st Floor

WIDTH: 3.12 m • LENGTH: 3.95 m
AREA: 12.33 m² • PERIMETER: 14.14 m

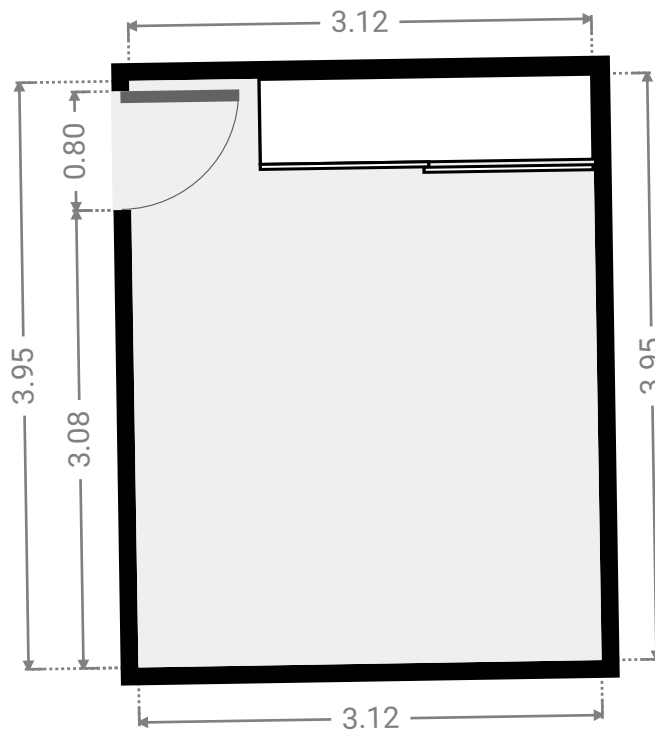
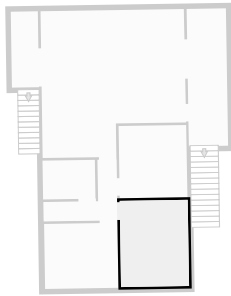

▼ **Bedroom**
1st Floor

WIDTH: 3.10 m • LENGTH: 3.32 m
AREA: 10.27 m² • PERIMETER: 12.83 m

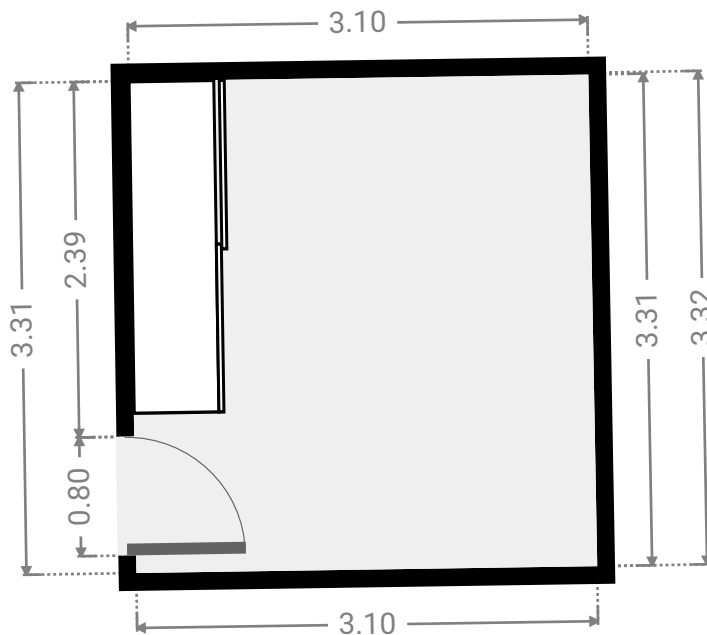
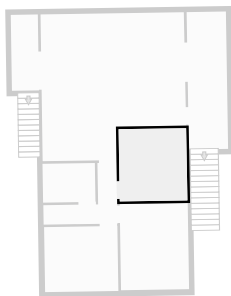

FLOORS: 2

▼ Other
1st Floor

WIDTH: 1.24 m • LENGTH: 3.48 m
AREA: 4.32 m² • PERIMETER: 9.44 m

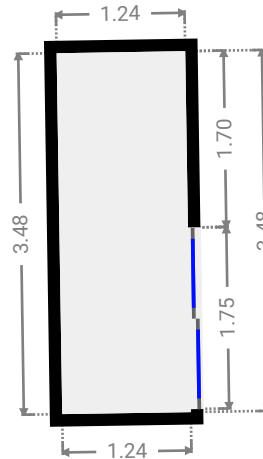
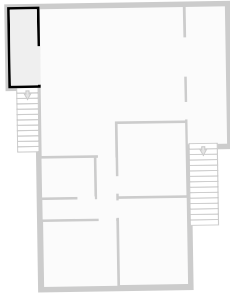

▼ Other
1st Floor

WIDTH: 1.80 m • LENGTH: 6.30 m
AREA: 11.34 m² • PERIMETER: 16.20 m

