

25 Mary STREET

SUBMITTED BY

Ray White Rockhampton Casey
stockers@cqoz.com

CREATED ON

2022-09-12

Floors

2

▼ Ground Floor

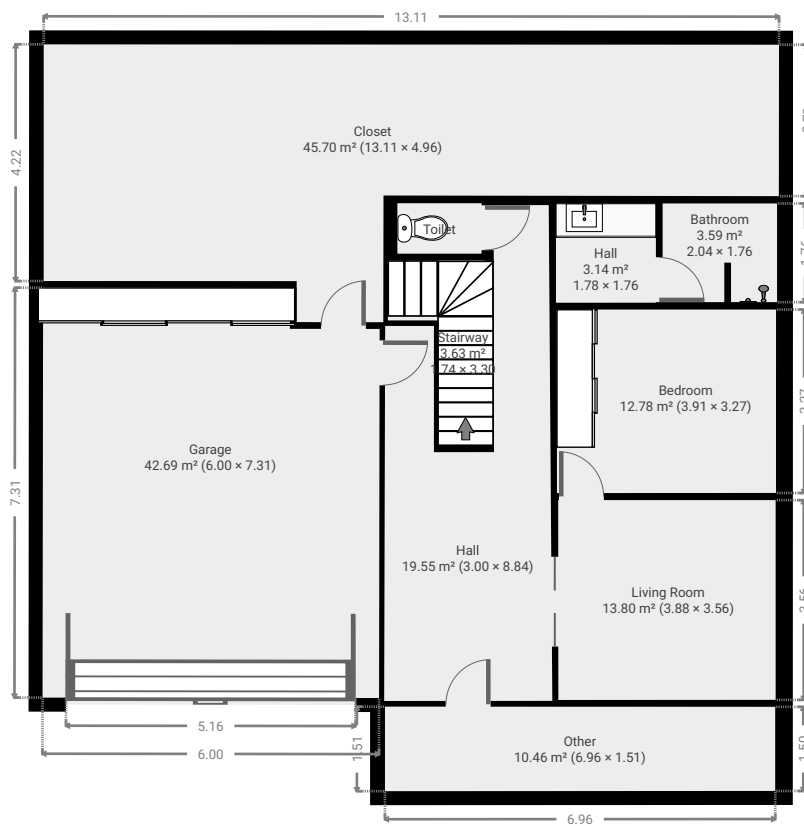

▼ Bathroom
Ground Floor

WIDTH: 2.04 m • LENGTH: 1.76 m
AREA: 3.59 m² • PERIMETER: 7.60 m

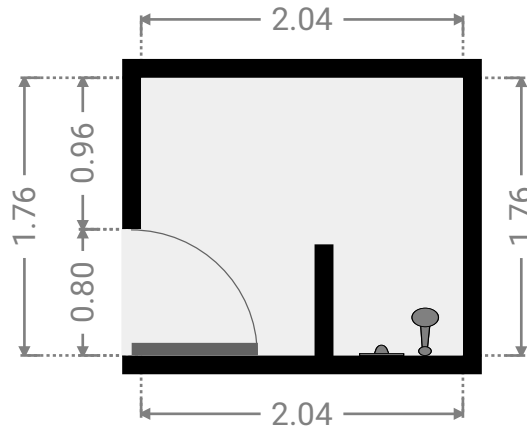
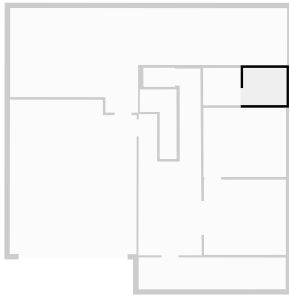

▼ Bedroom
Ground Floor

WIDTH: 3.91 m • LENGTH: 3.27 m
AREA: 12.78 m² • PERIMETER: 14.36 m

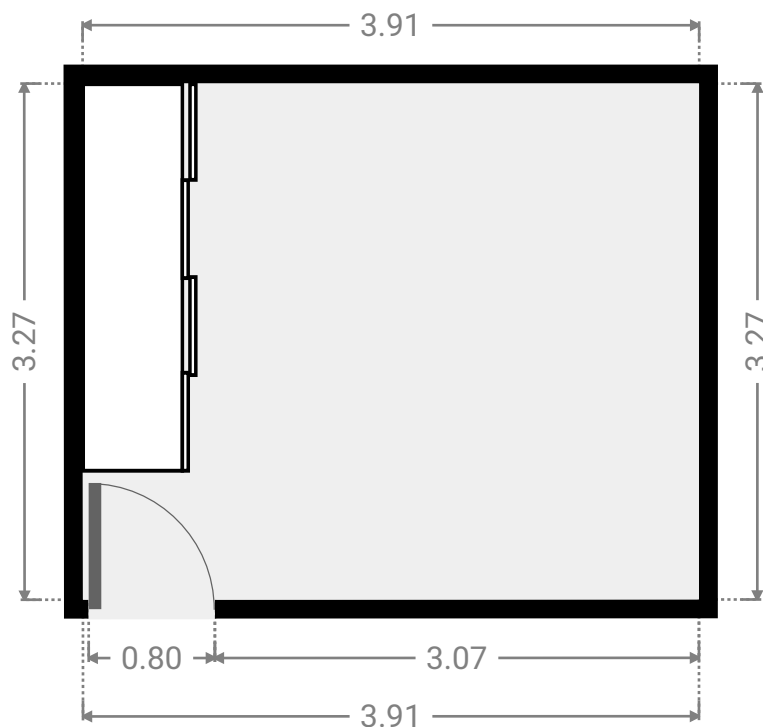
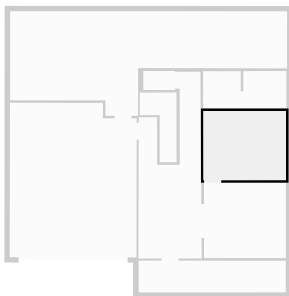

▼ Garage Ground Floor

WIDTH: 6.00 m • LENGTH: 7.31 m
AREA: 42.69 m² • PERIMETER: 26.62 m

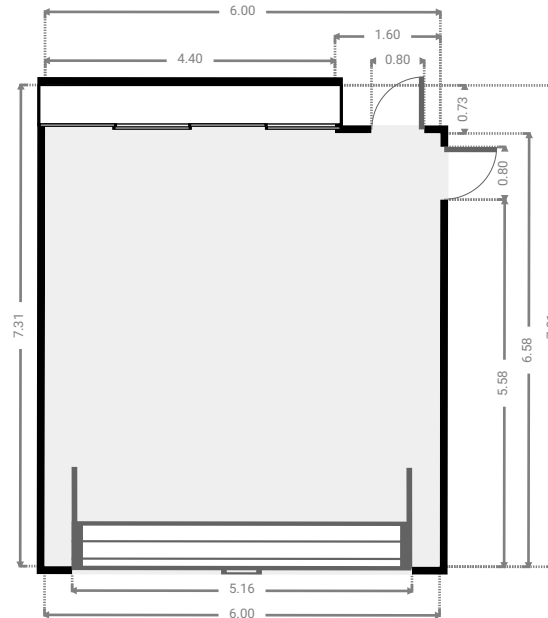
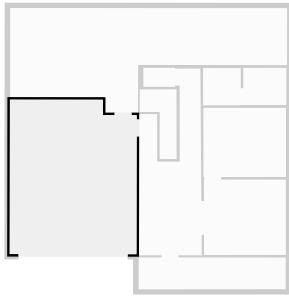

▼ Closet Ground Floor

WIDTH: 13.11 m • LENGTH: 4.96 m
AREA: 45.70 m² • PERIMETER: 36.13 m

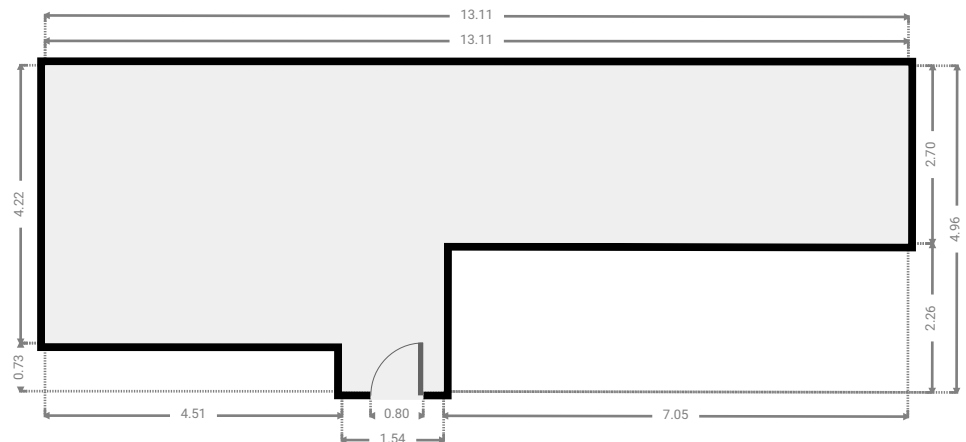
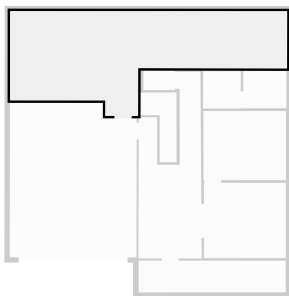

▼ Hall Ground Floor

WIDTH: 3.00 m • LENGTH: 8.84 m
AREA: 19.55 m² • PERIMETER: 28.10 m

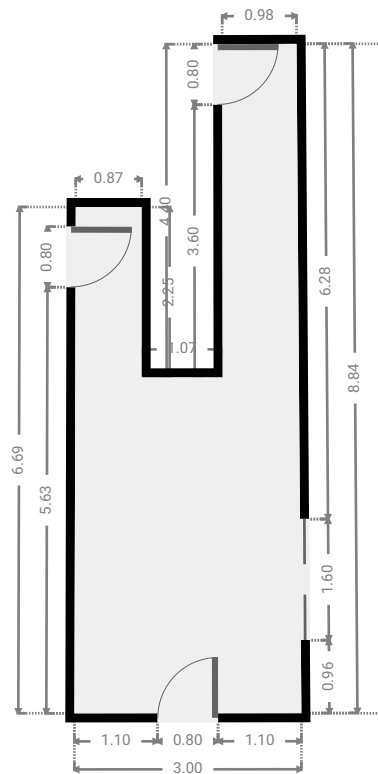
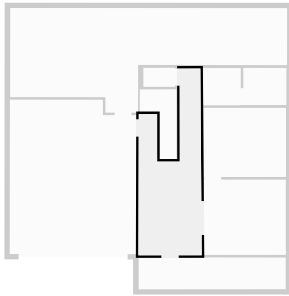

▼ Hall Ground Floor

WIDTH: 1.78 m • LENGTH: 1.76 m
AREA: 3.14 m² • PERIMETER: 7.09 m

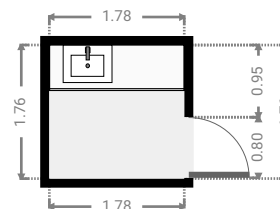
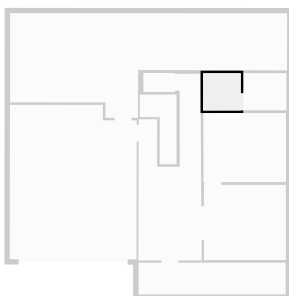

▼ **Living Room**
Ground Floor

WIDTH: 3.88 m • LENGTH: 3.56 m
AREA: 13.80 m² • PERIMETER: 14.87 m

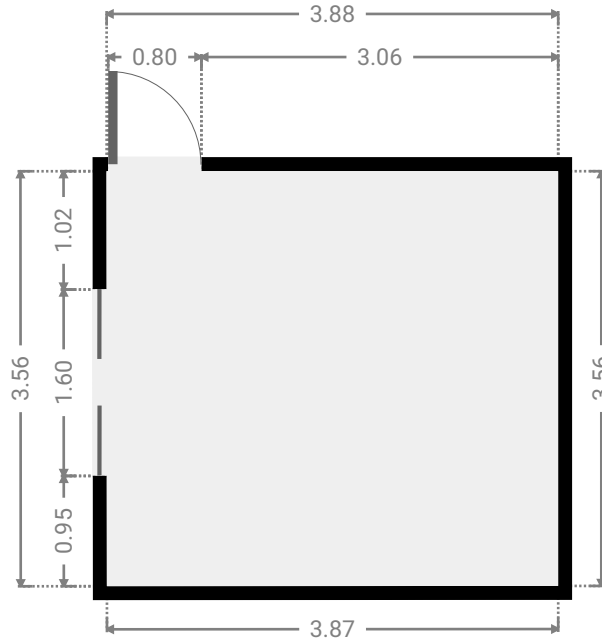
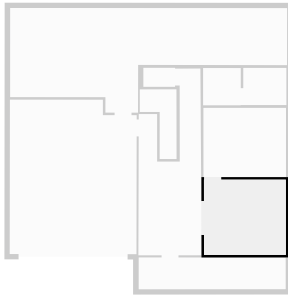

▼ **Other**
Ground Floor

WIDTH: 6.96 m • LENGTH: 1.51 m
AREA: 10.46 m² • PERIMETER: 16.92 m

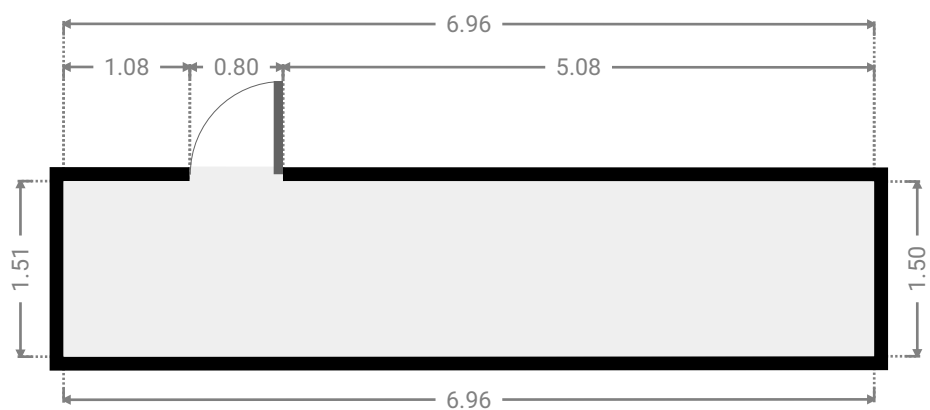
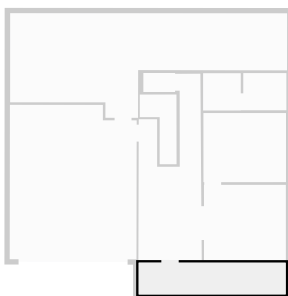

▼ **Stairway**
Ground Floor

WIDTH: 1.74 m • LENGTH: 3.30 m
AREA: 3.63 m² • PERIMETER: 10.07 m

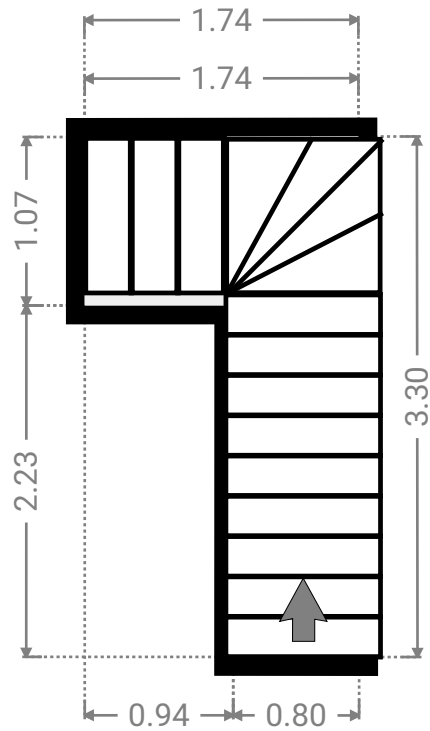
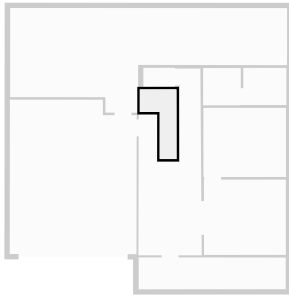

▼ **Toilet**
Ground Floor

WIDTH: 1.50 m • LENGTH: 0.90 m
AREA: 1.35 m² • PERIMETER: 4.80 m

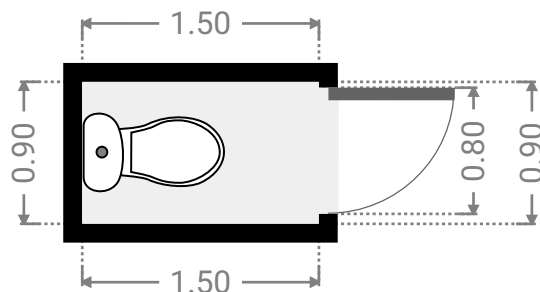
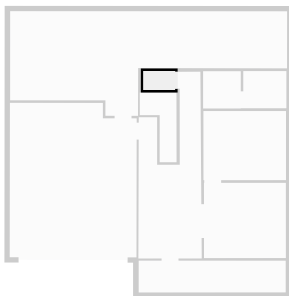

▼ 1st Floor

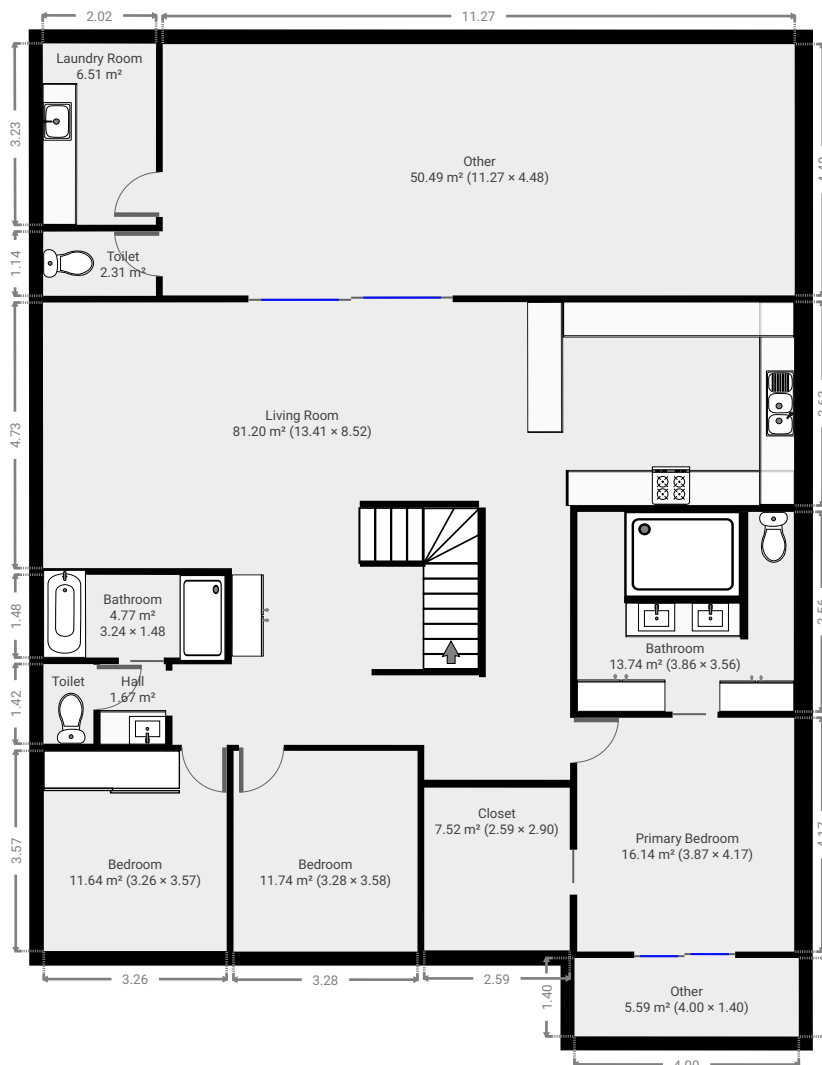
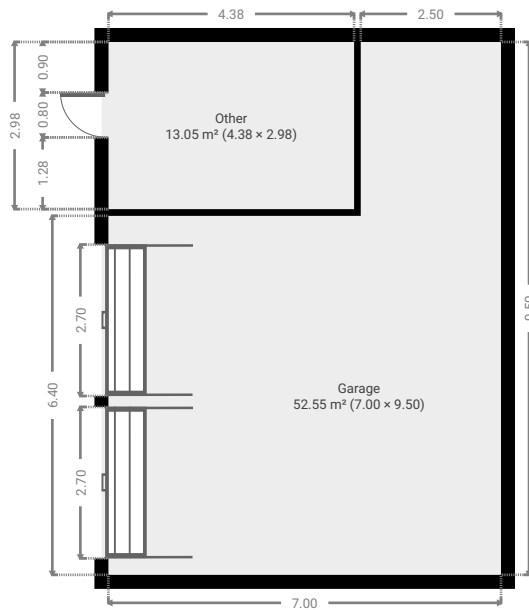

▼ Bathroom
1st Floor

WIDTH: 3.86 m • LENGTH: 3.56 m
AREA: 13.74 m² • PERIMETER: 14.84 m

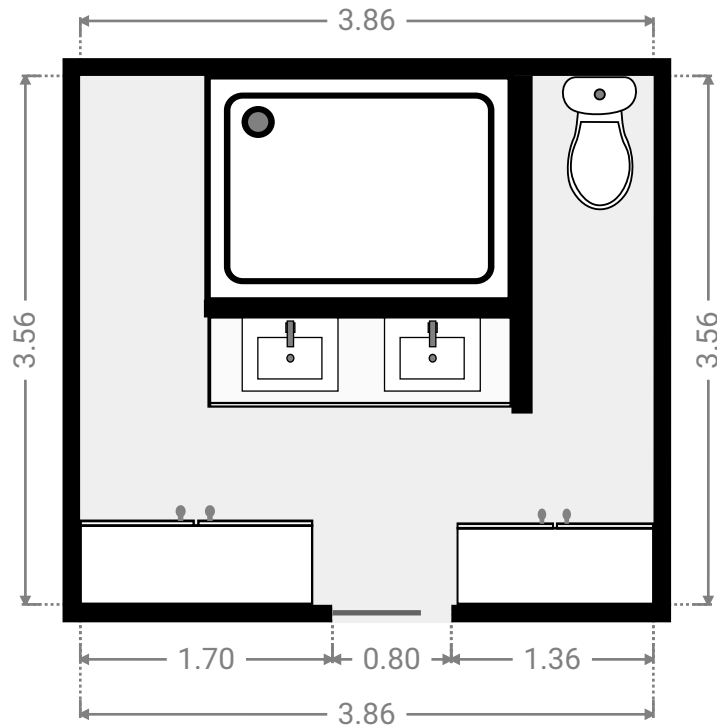
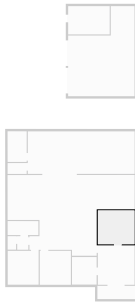

▼ Bathroom
1st Floor

WIDTH: 3.24 m • LENGTH: 1.48 m
AREA: 4.77 m² • PERIMETER: 9.43 m

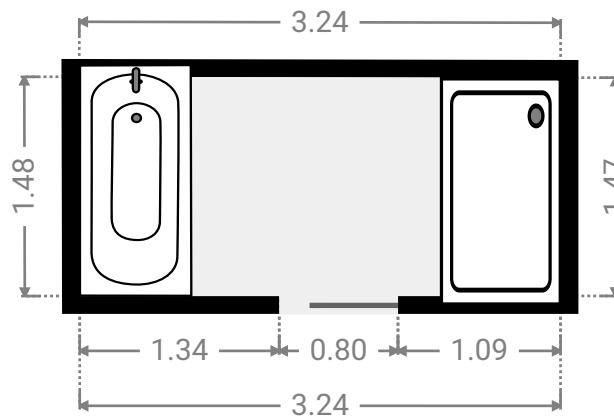
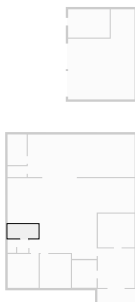

▼ **Bedroom**
1st Floor

WIDTH: 3.28 m • LENGTH: 3.58 m
AREA: 11.74 m² • PERIMETER: 13.72 m

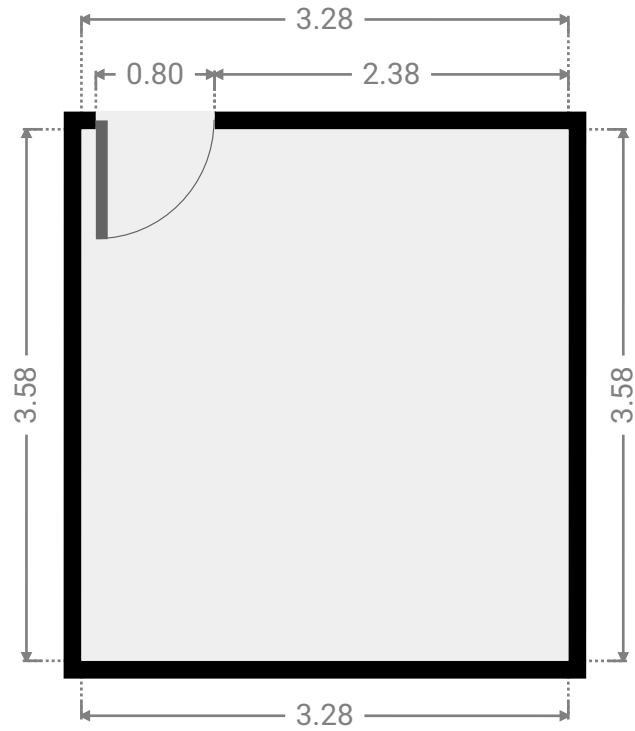
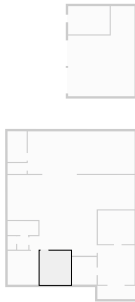

▼ **Bedroom**
1st Floor

WIDTH: 3.26 m • LENGTH: 3.57 m
AREA: 11.64 m² • PERIMETER: 13.66 m

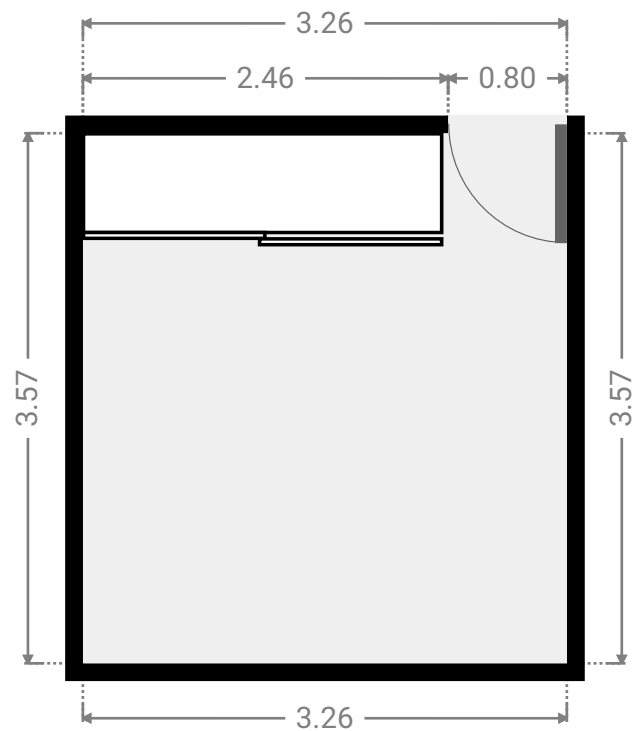
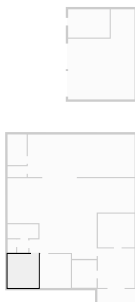

▼ Garage 1st Floor

WIDTH: 7.00 m • LENGTH: 9.50 m
AREA: 52.55 m² • PERIMETER: 33.00 m

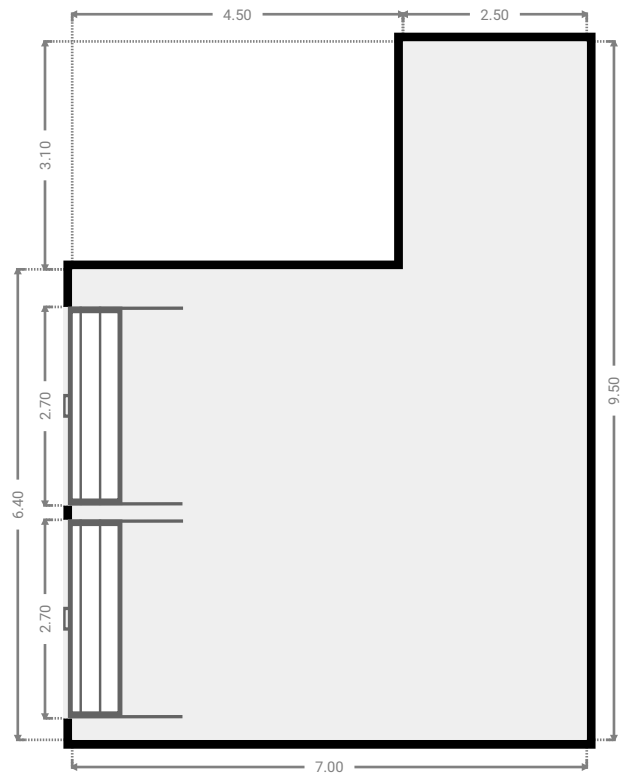
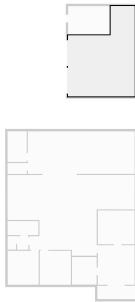

▼ Hall 1st Floor

WIDTH: 1.17 m • LENGTH: 1.43 m
AREA: 1.67 m² • PERIMETER: 5.20 m

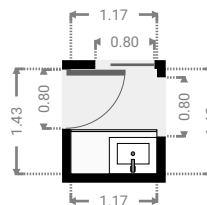
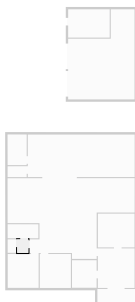

▼ **Laundry Room**
1st Floor

WIDTH: 2.02 m • LENGTH: 3.23 m
AREA: 6.51 m² • PERIMETER: 10.49 m

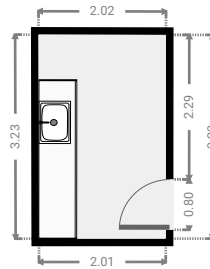
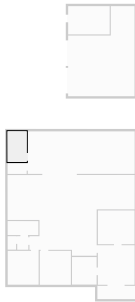

▼ **Living Room**
1st Floor

WIDTH: 13.41 m • LENGTH: 8.52 m
AREA: 81.20 m² • PERIMETER: 45.95 m

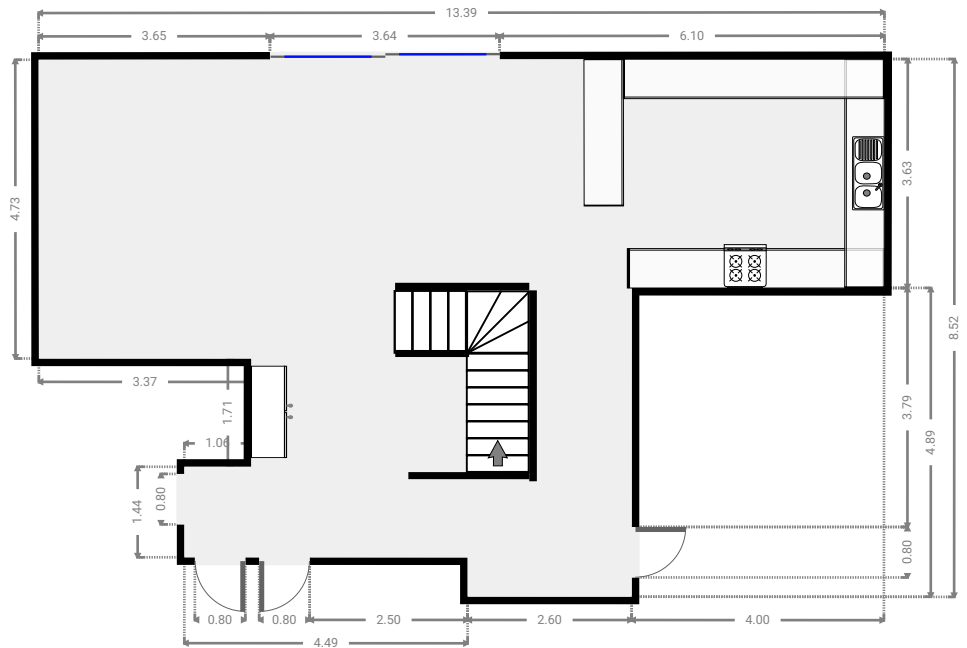
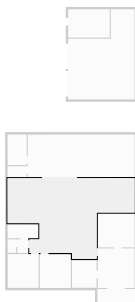

▼ Other
1st Floor

WIDTH: 11.27 m • LENGTH: 4.48 m
AREA: 50.49 m² • PERIMETER: 31.50 m

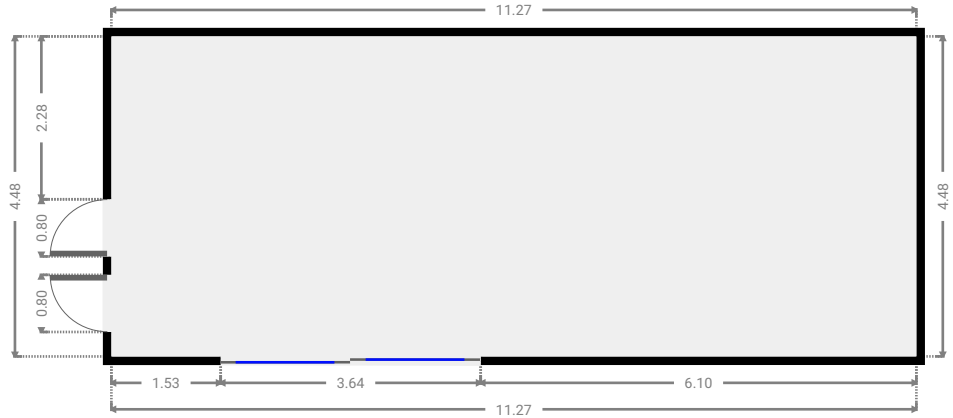
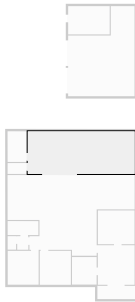

▼ Other
1st Floor

WIDTH: 4.38 m • LENGTH: 2.98 m
AREA: 13.05 m² • PERIMETER: 14.72 m

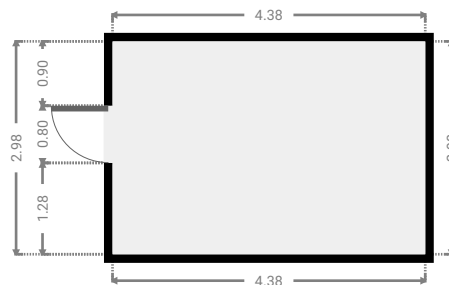
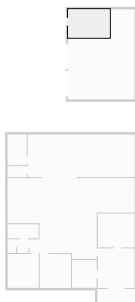

▼ Other 1st Floor

WIDTH: 4.00 m • LENGTH: 1.40 m
AREA: 5.59 m² • PERIMETER: 10.79 m

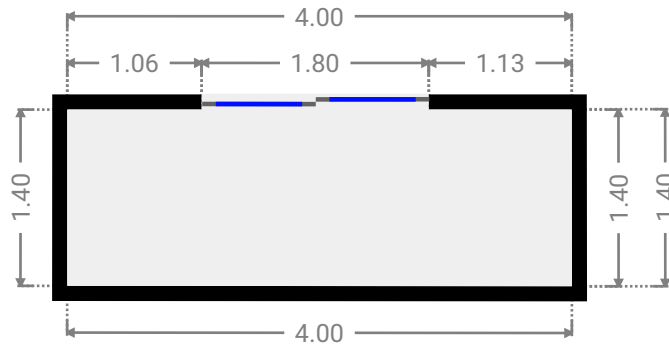
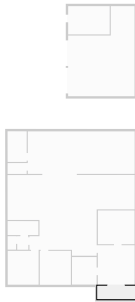

▼ Primary Bedroom 1st Floor

WIDTH: 3.87 m • LENGTH: 4.17 m
AREA: 16.14 m² • PERIMETER: 16.08 m

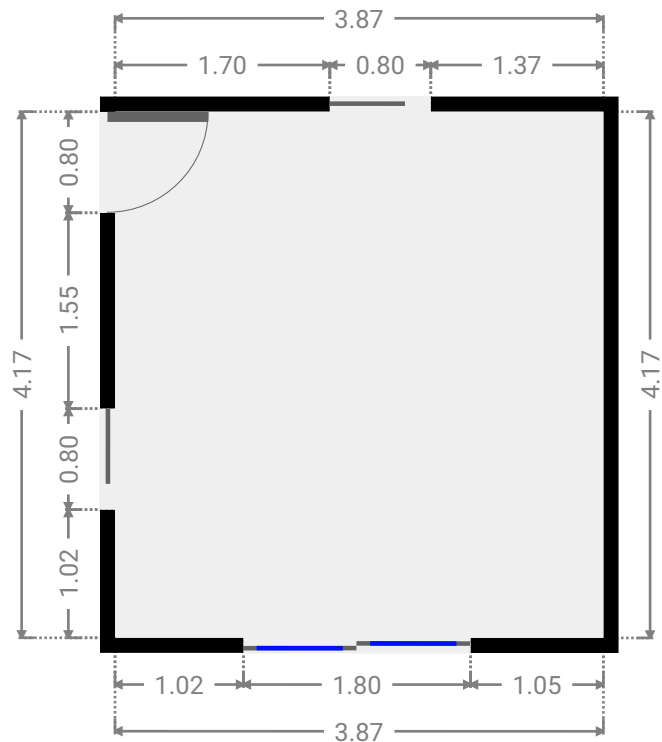
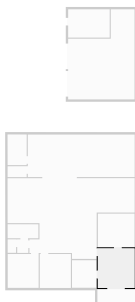

▼ **Closet**
1st Floor

WIDTH: 2.59 m • LENGTH: 2.90 m
AREA: 7.52 m² • PERIMETER: 10.99 m

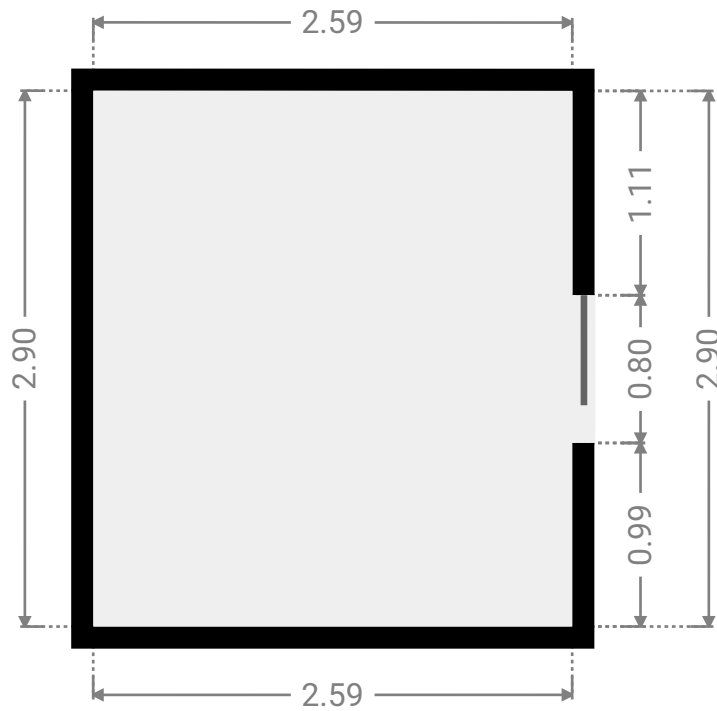
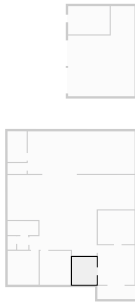

▼ **Toilet**
1st Floor

WIDTH: 0.89 m • LENGTH: 1.42 m
AREA: 1.26 m² • PERIMETER: 4.62 m

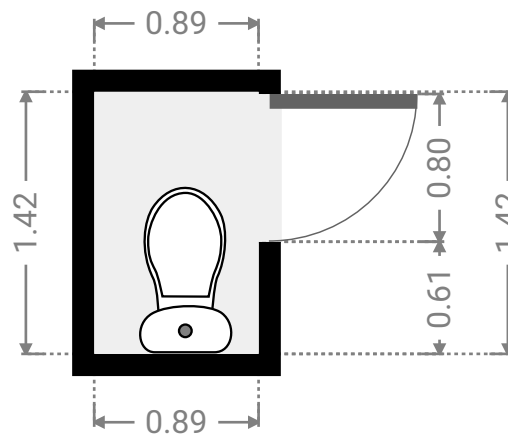
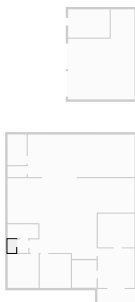

▼ Toilet
1st Floor

WIDTH: 2.01 m • LENGTH: 1.15 m
AREA: 2.31 m² • PERIMETER: 6.32 m

