

25 Inveraray Way

Created on
2021-03-16

Floors
1

▼ Ground Floor

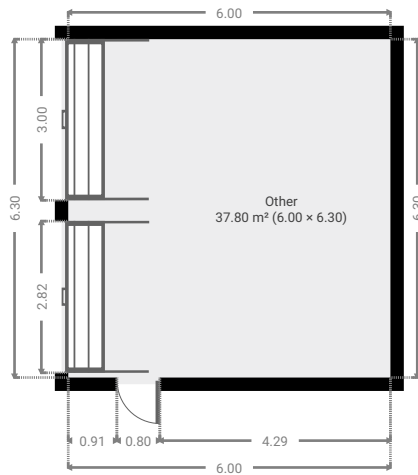

▼ **Bedroom**
Ground Floor

WIDTH: 4.83 m • LENGTH: 4.44 m
AREA: 15.11 m² • PERIMETER: 18.36 m

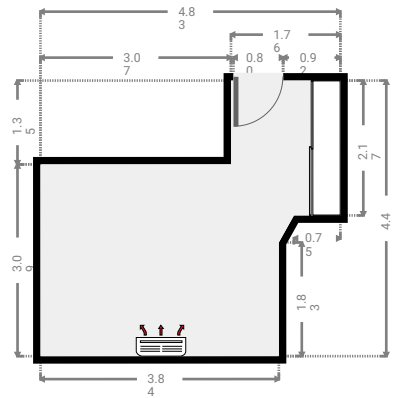
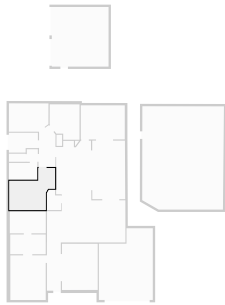

▼ **Other**
Ground Floor

WIDTH: 8.64 m • LENGTH: 10.93 m
AREA: 92.86 m² • PERIMETER: 38.28 m

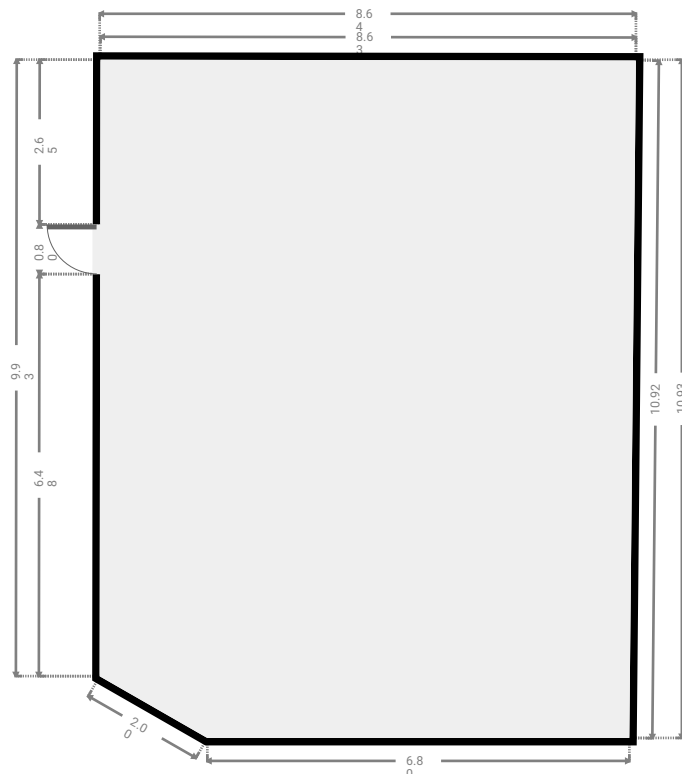
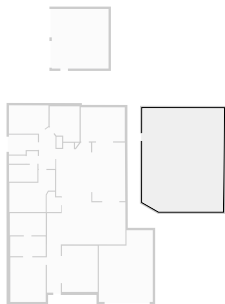

▼ Other Ground Floor

WIDTH: 6.00 m • LENGTH: 6.30 m
AREA: 37.80 m² • PERIMETER: 24.60 m

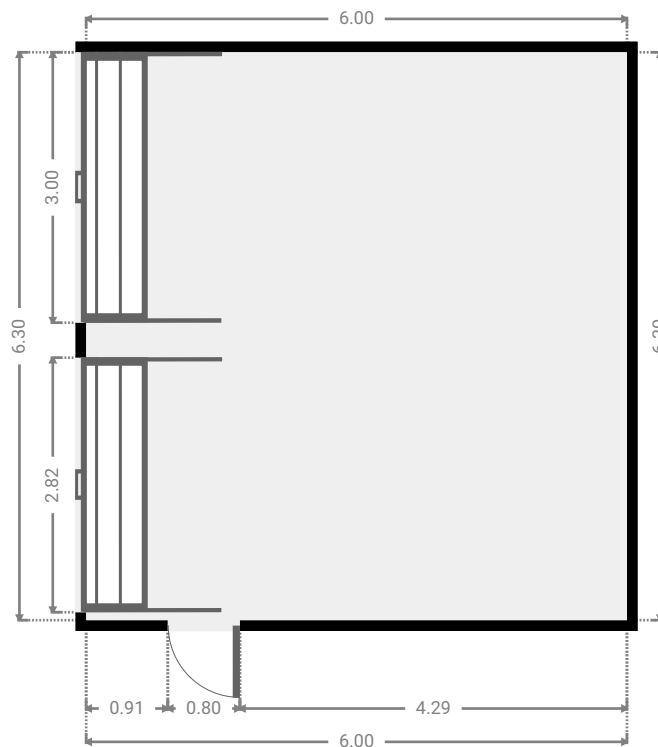
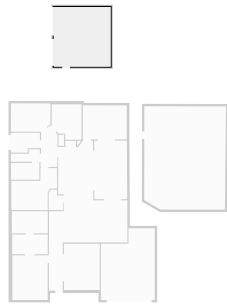

▼ Other Ground Floor

WIDTH: 3.50 m • LENGTH: 6.20 m
AREA: 21.48 m² • PERIMETER: 19.32 m

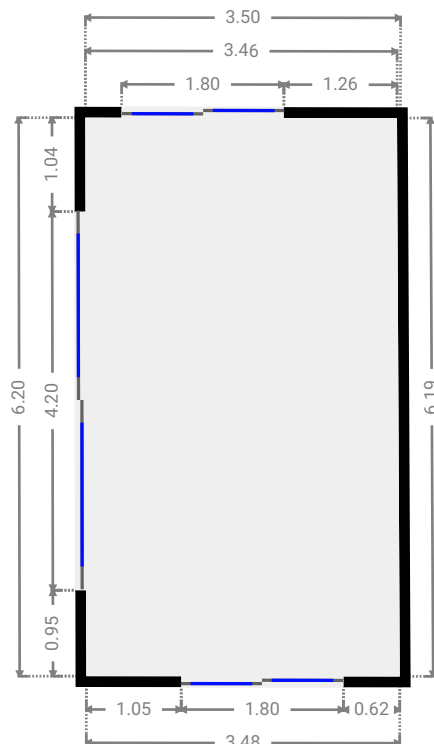
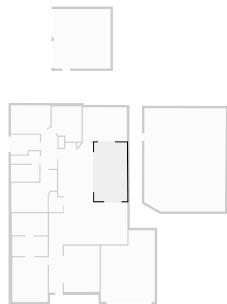

▼ **Bedroom**
Ground Floor

WIDTH: 4.19 m • LENGTH: 3.00 m
AREA: 12.08 m² • PERIMETER: 13.81 m

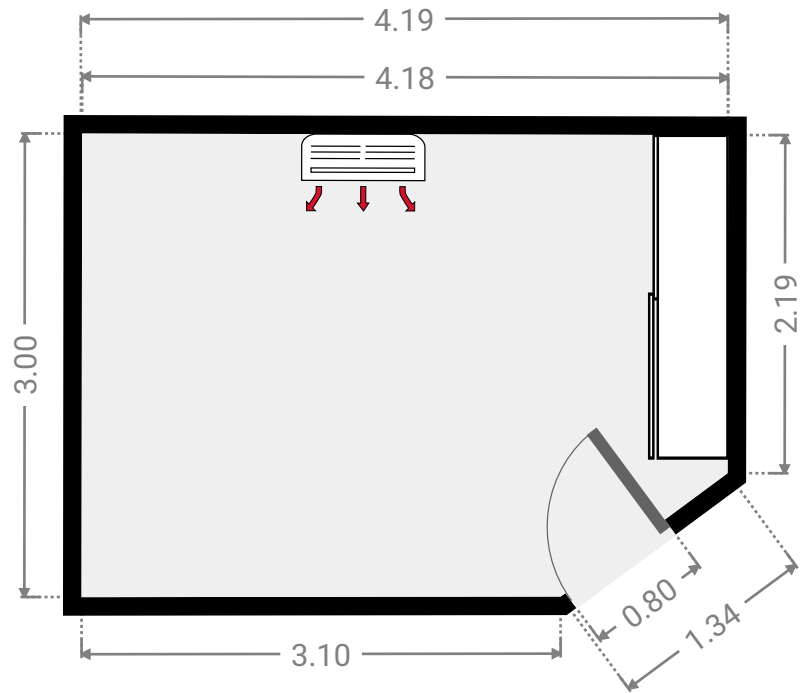
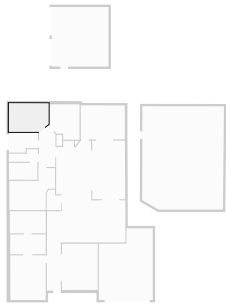

▼ **Closet**
Ground Floor

WIDTH: 0.59 m • LENGTH: 1.17 m
AREA: 0.69 m² • PERIMETER: 3.53 m

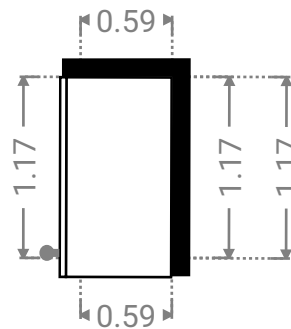
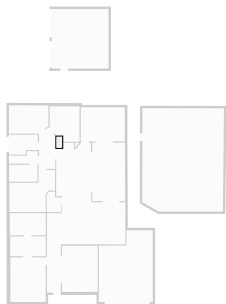

▼ **Bedroom**
Ground Floor

WIDTH: 3.16 m • LENGTH: 3.75 m
AREA: 10.53 m² • PERIMETER: 13.31 m

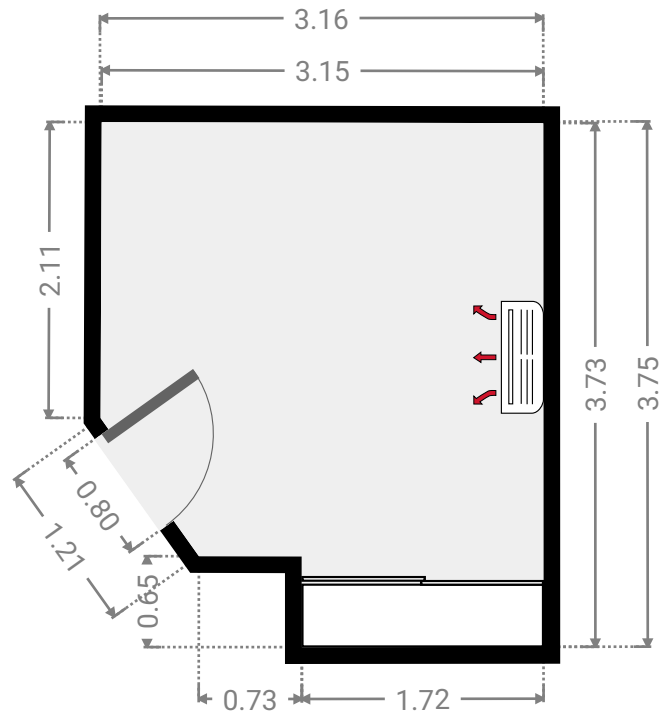
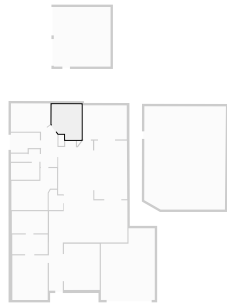

▼ **Laundry Room**
Ground Floor

WIDTH: 3.07 m • LENGTH: 2.10 m
AREA: 5.82 m² • PERIMETER: 10.33 m

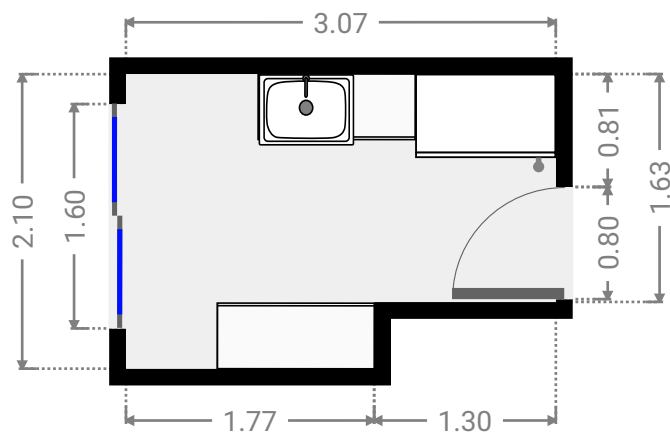
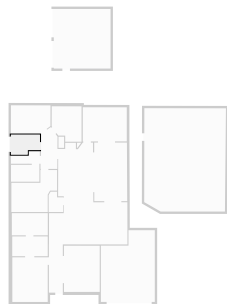

▼ Toilet Ground Floor

WIDTH: 1.77 m • LENGTH: 0.85 m
AREA: 1.51 m² • PERIMETER: 5.24 m

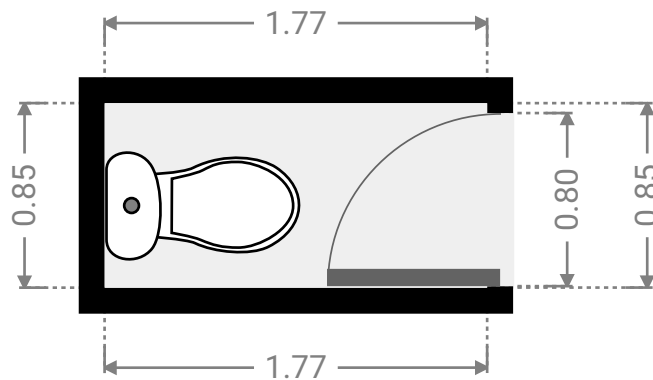
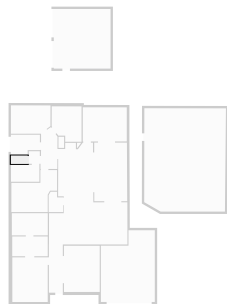

▼ Bathroom Ground Floor

WIDTH: 3.00 m • LENGTH: 1.78 m
AREA: 5.34 m² • PERIMETER: 9.56 m

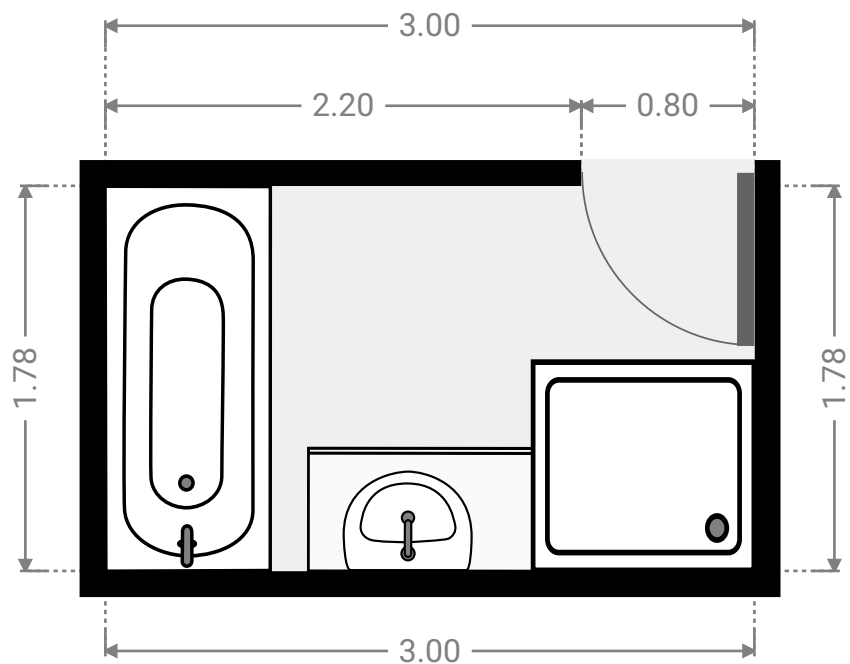
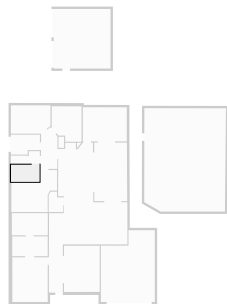

▼ Hall
Ground Floor

WIDTH: 1.47 m • LENGTH: 5.00 m
AREA: 7.35 m² • PERIMETER: 12.94 m

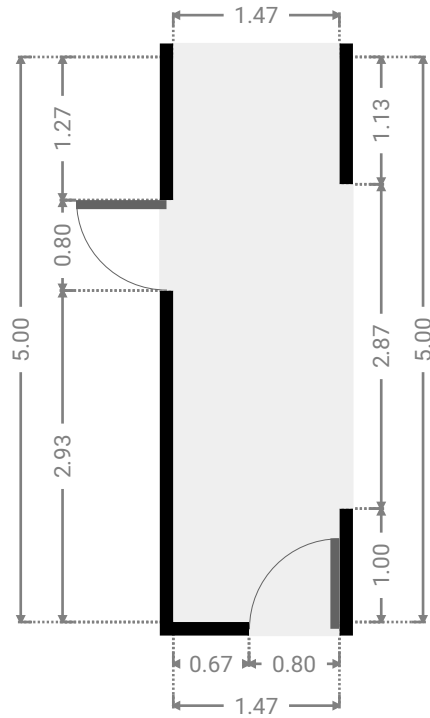
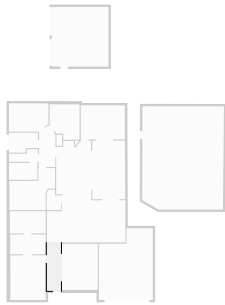

▼ Hall
Ground Floor

WIDTH: 3.03 m • LENGTH: 4.42 m
AREA: 8.59 m² • PERIMETER: 14.89 m

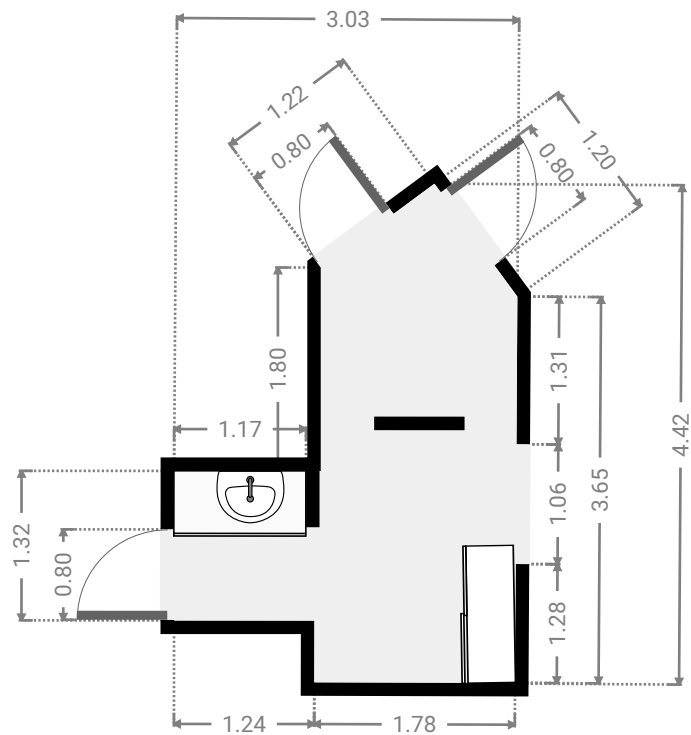
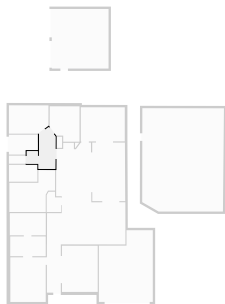

▼ Bedroom Ground Floor

WIDTH: 4.66 m • LENGTH: 3.61 m
AREA: 16.77 m² • PERIMETER: 16.51 m

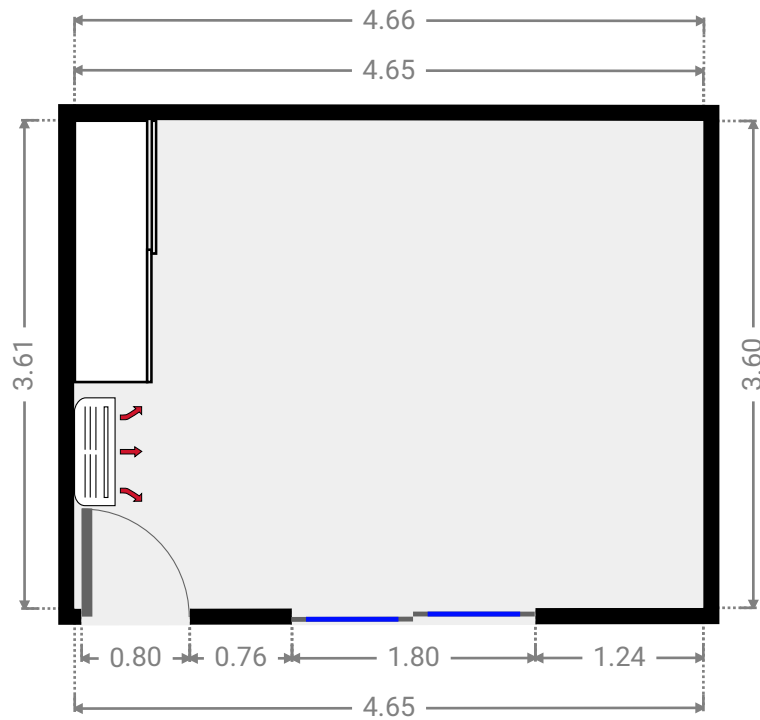
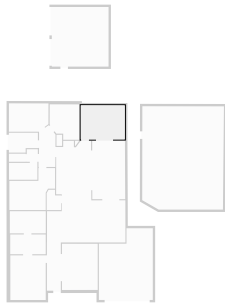

▼ Closet Ground Floor

WIDTH: 1.53 m • LENGTH: 2.15 m
AREA: 2.86 m² • PERIMETER: 7.21 m

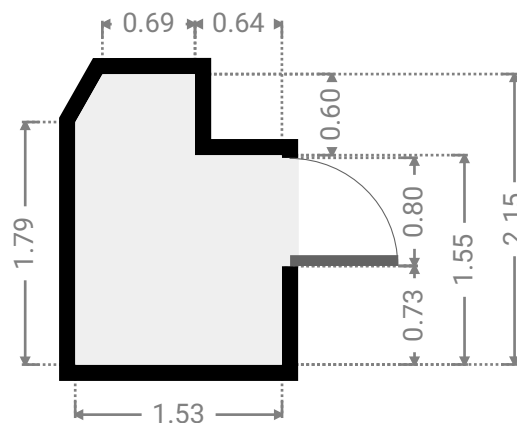
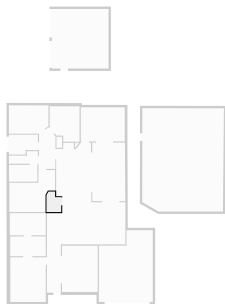

▼ **Garage**
Ground Floor

WIDTH: 5.70 m • LENGTH: 7.58 m
AREA: 38.45 m² • PERIMETER: 26.56 m

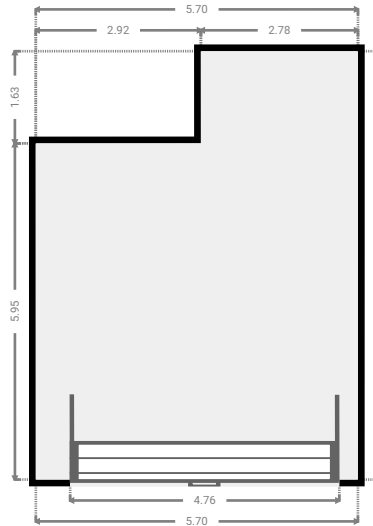

▼ **Kitchen**
Ground Floor

WIDTH: 8.30 m • LENGTH: 10.77 m
AREA: 57.21 m² • PERIMETER: 40.27 m

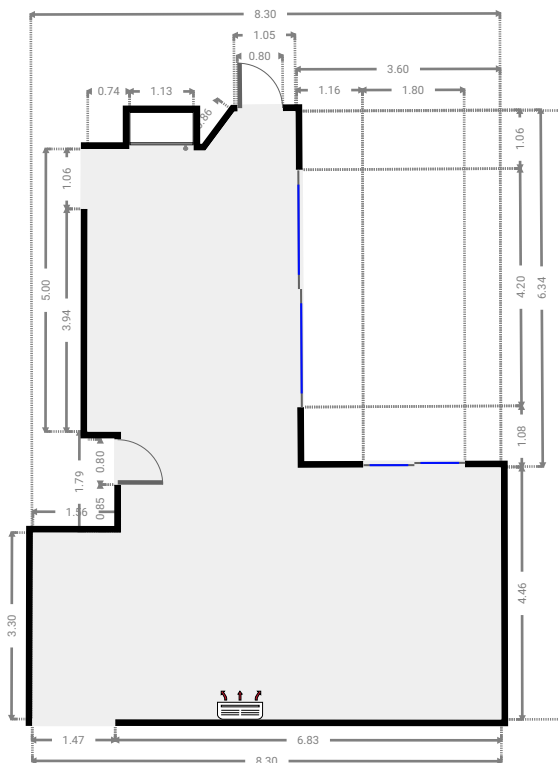
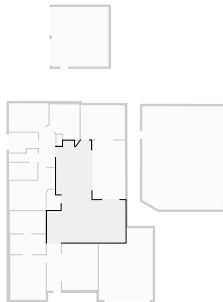

▼ **Bathroom**
Ground Floor

WIDTH: 3.80 m • LENGTH: 2.34 m
AREA: 8.89 m² • PERIMETER: 12.28 m

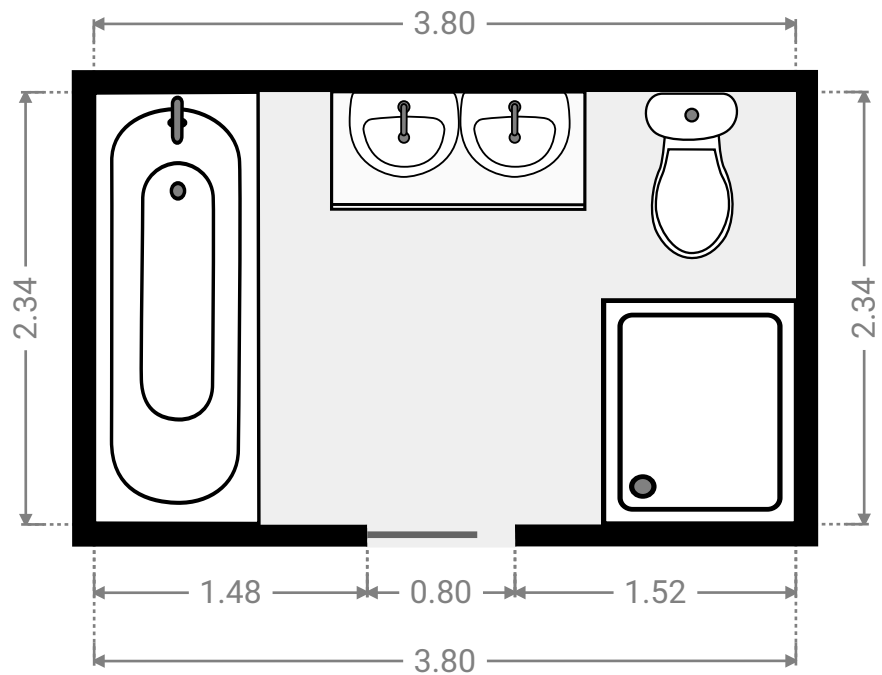
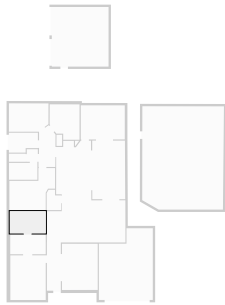

▼ **Closet**
Ground Floor

WIDTH: 3.75 m • LENGTH: 2.09 m
AREA: 7.84 m² • PERIMETER: 11.68 m

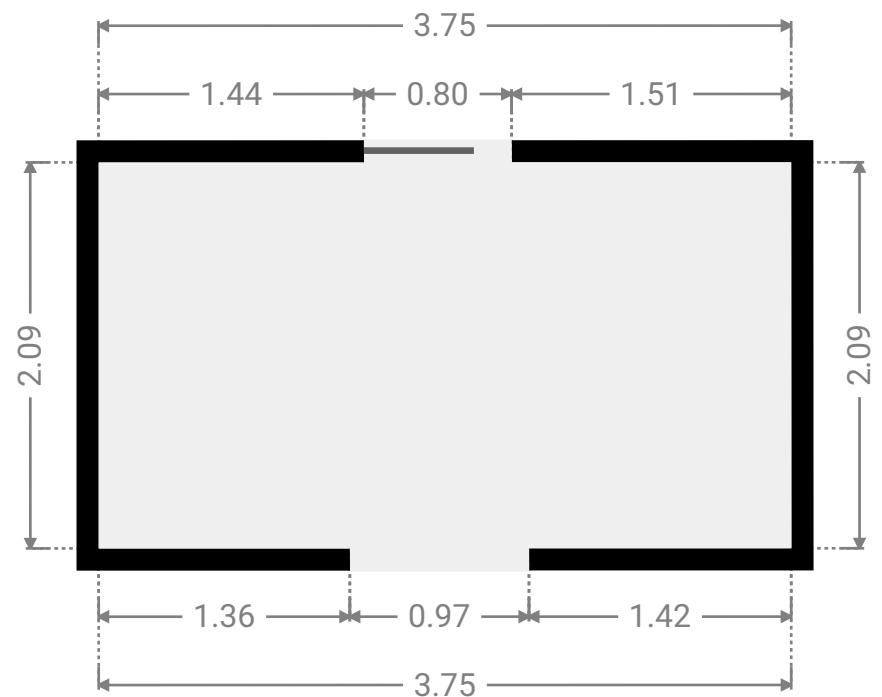
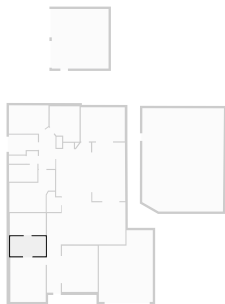

▼ Master Bedroom Ground Floor

WIDTH: 3.74 m • LENGTH: 4.72 m
AREA: 17.65 m² • PERIMETER: 16.92 m

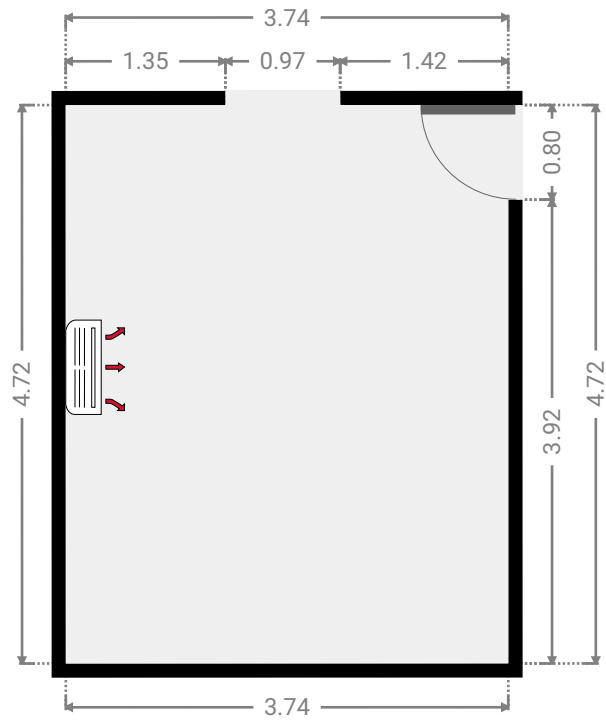
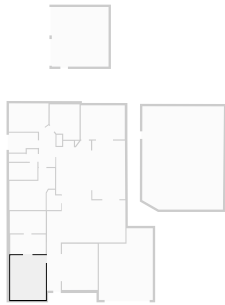

▼ Living Room Ground Floor

WIDTH: 3.78 m • LENGTH: 4.89 m
AREA: 18.46 m² • PERIMETER: 17.33 m

