

25 Dunbar Street

SUBMITTED BY

Ray White Rockhampton Casey
stockers@cqoz.com

CREATED ON

2021-11-02

Floors

1

▼ Ground Floor



▼ Living Room
Ground Floor

WIDTH: 4.63 m • LENGTH: 3.95 m
AREA: 18.29 m² • PERIMETER: 17.16 m

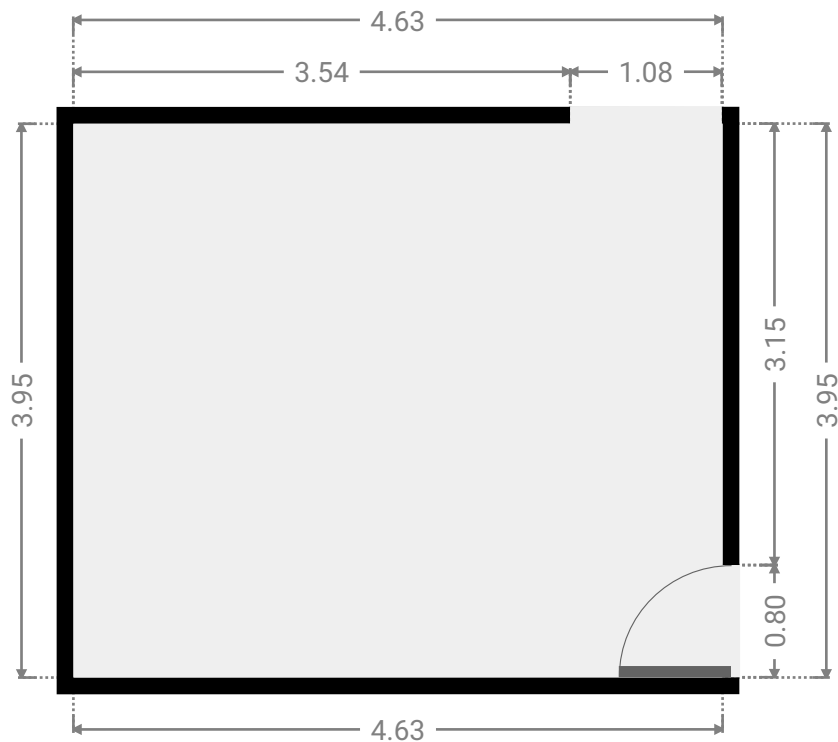
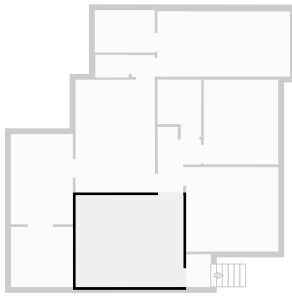

▼ Hall
Ground Floor

WIDTH: 1.87 m • LENGTH: 2.82 m
AREA: 3.77 m² • PERIMETER: 9.34 m

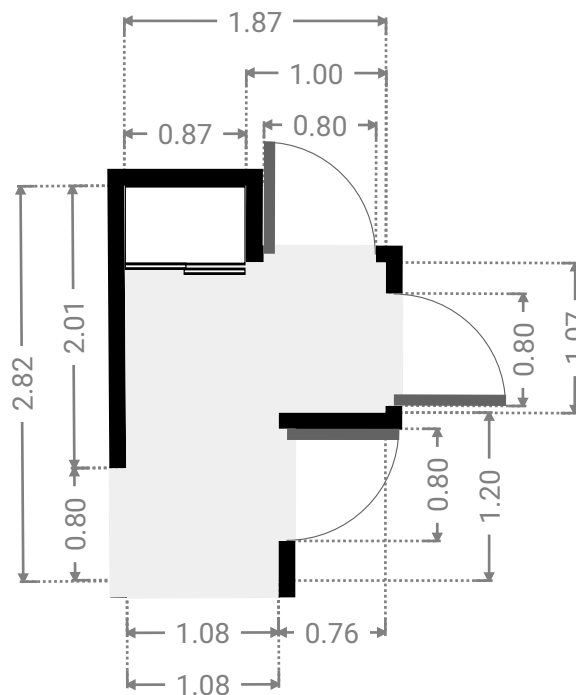
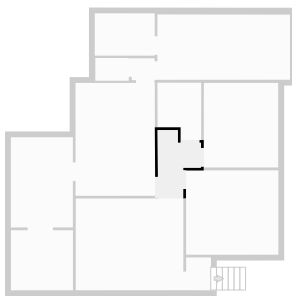

▼ **Bedroom**
Ground Floor

WIDTH: 3.97 m • LENGTH: 3.63 m
AREA: 14.41 m² • PERIMETER: 15.20 m

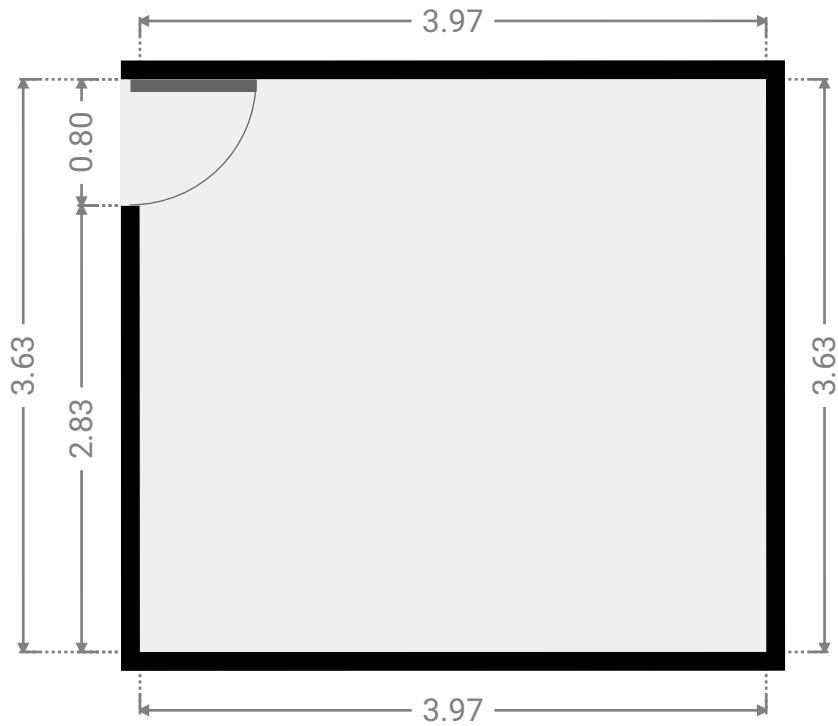
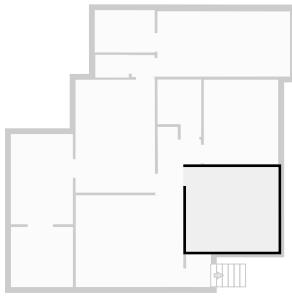

▼ **Bedroom**
Ground Floor

WIDTH: 3.20 m • LENGTH: 3.64 m
AREA: 11.65 m² • PERIMETER: 13.68 m

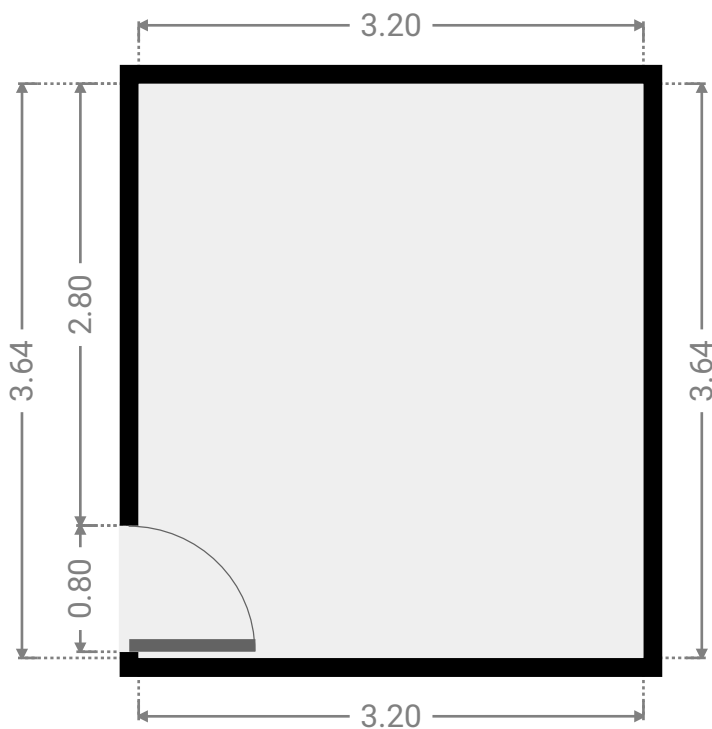
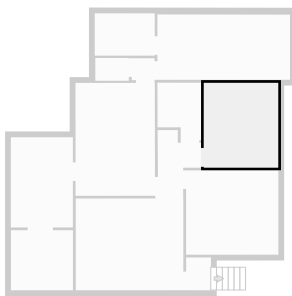

▼ **Bathroom**
Ground Floor

WIDTH: 1.89 m • LENGTH: 2.47 m
AREA: 4.09 m² • PERIMETER: 8.69 m

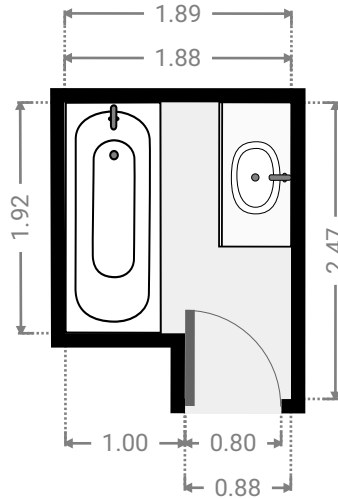
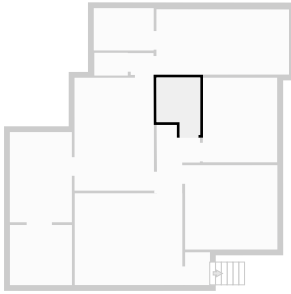

▼ **Kitchen**
Ground Floor

WIDTH: 3.42 m • LENGTH: 4.86 m
AREA: 16.60 m² • PERIMETER: 16.55 m

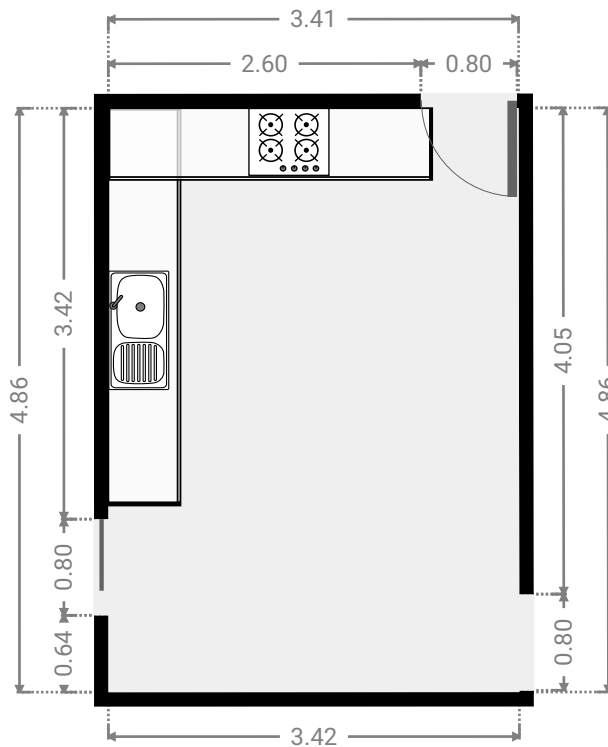
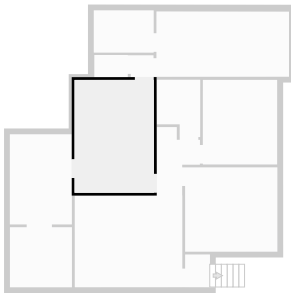

FLOORS: 1

▼ **Bedroom**
Ground Floor

WIDTH: 2.67 m • LENGTH: 3.88 m
AREA: 10.36 m² • PERIMETER: 13.10 m

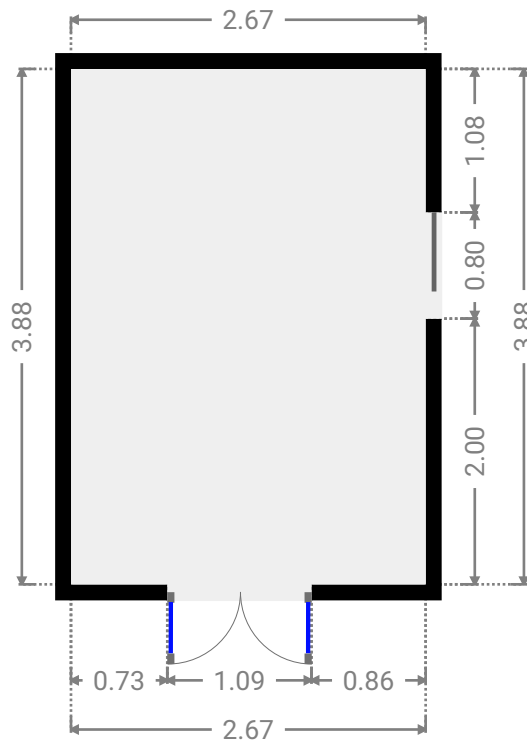
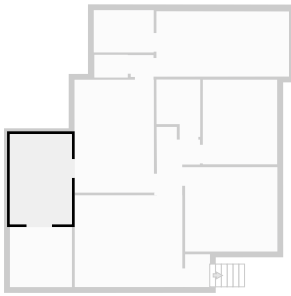

▼ **Other**
Ground Floor

WIDTH: 2.67 m • LENGTH: 2.59 m
AREA: 6.91 m² • PERIMETER: 10.51 m

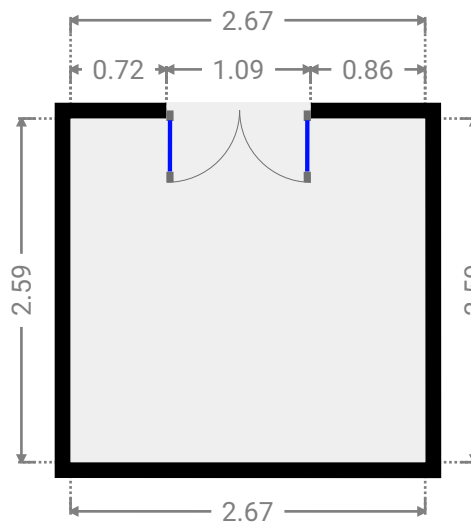
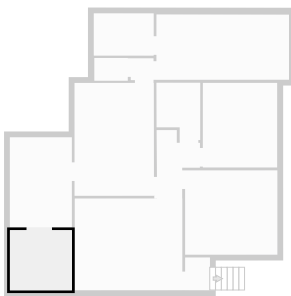

▼ **Hall**
Ground Floor

WIDTH: 0.98 m • LENGTH: 0.94 m
AREA: 0.92 m² • PERIMETER: 3.84 m

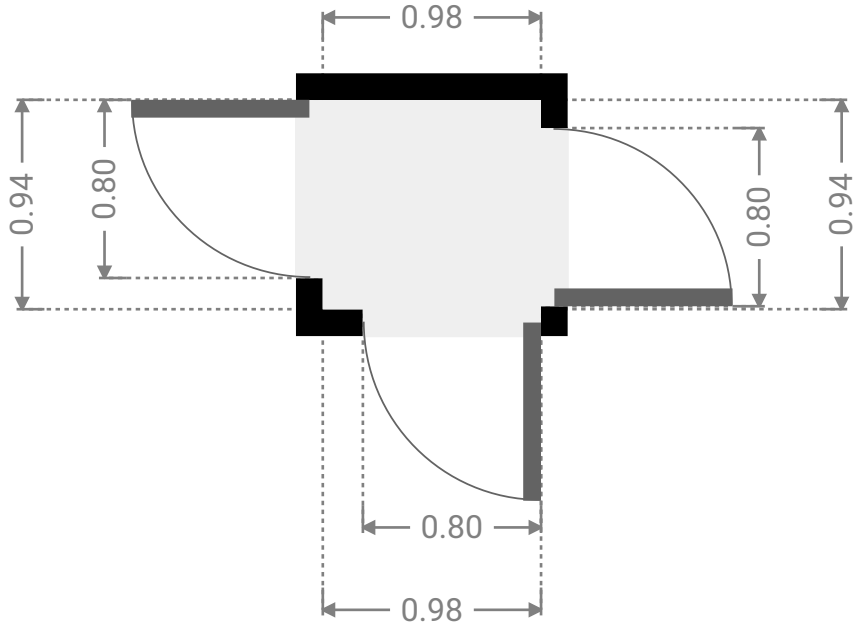
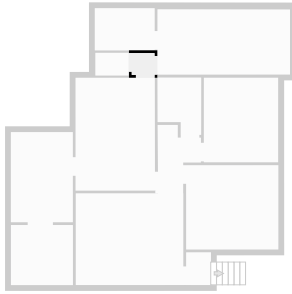

▼ **Toilet**
Ground Floor

WIDTH: 1.44 m • LENGTH: 0.98 m
AREA: 1.41 m² • PERIMETER: 4.84 m

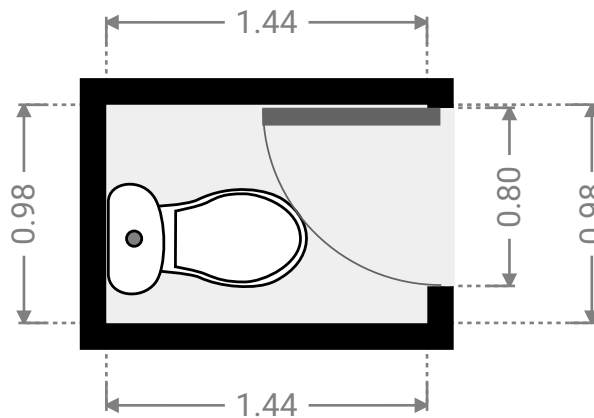
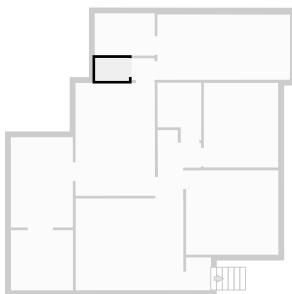

FLOORS: 1

▼ Laundry Room
Ground Floor

WIDTH: 2.58 m • LENGTH: 1.82 m
AREA: 4.69 m² • PERIMETER: 8.80 m

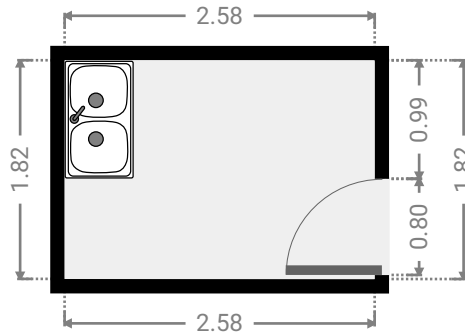
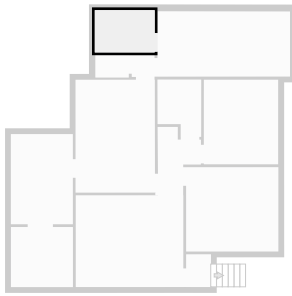

▼ Garage
Ground Floor

WIDTH: 5.71 m • LENGTH: 2.81 m
AREA: 16.02 m² • PERIMETER: 17.03 m

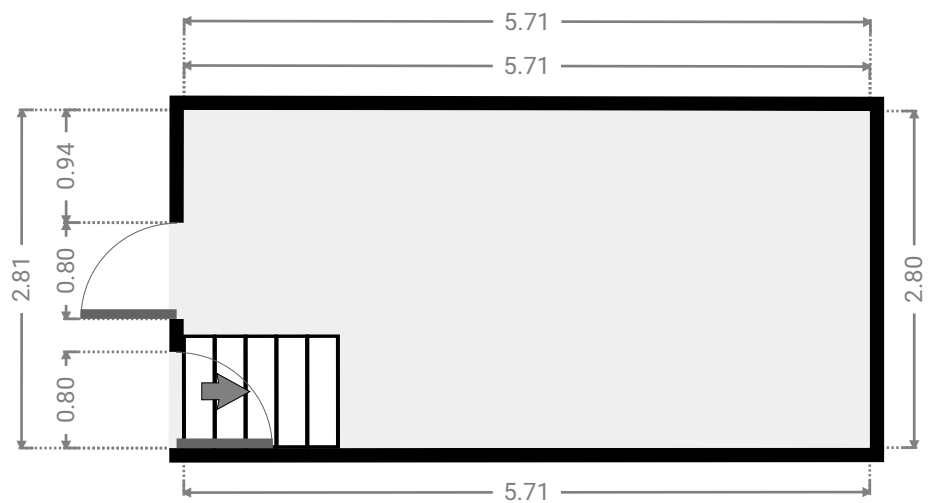
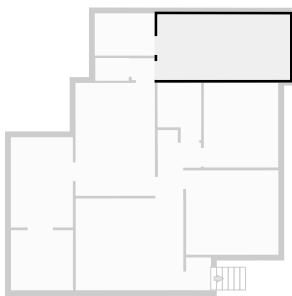

▼ Other
Ground Floor

WIDTH: 1.07 m • LENGTH: 1.41 m
AREA: 1.50 m² • PERIMETER: 4.95 m

