

# 25 Benjamin Drive

**SUBMITTED BY**

Ray White Rockhampton Casey  
stockers@cqoz.com

---

**CREATED ON**

2022-08-24

---

**Floors**

1

---

▼ Ground Floor

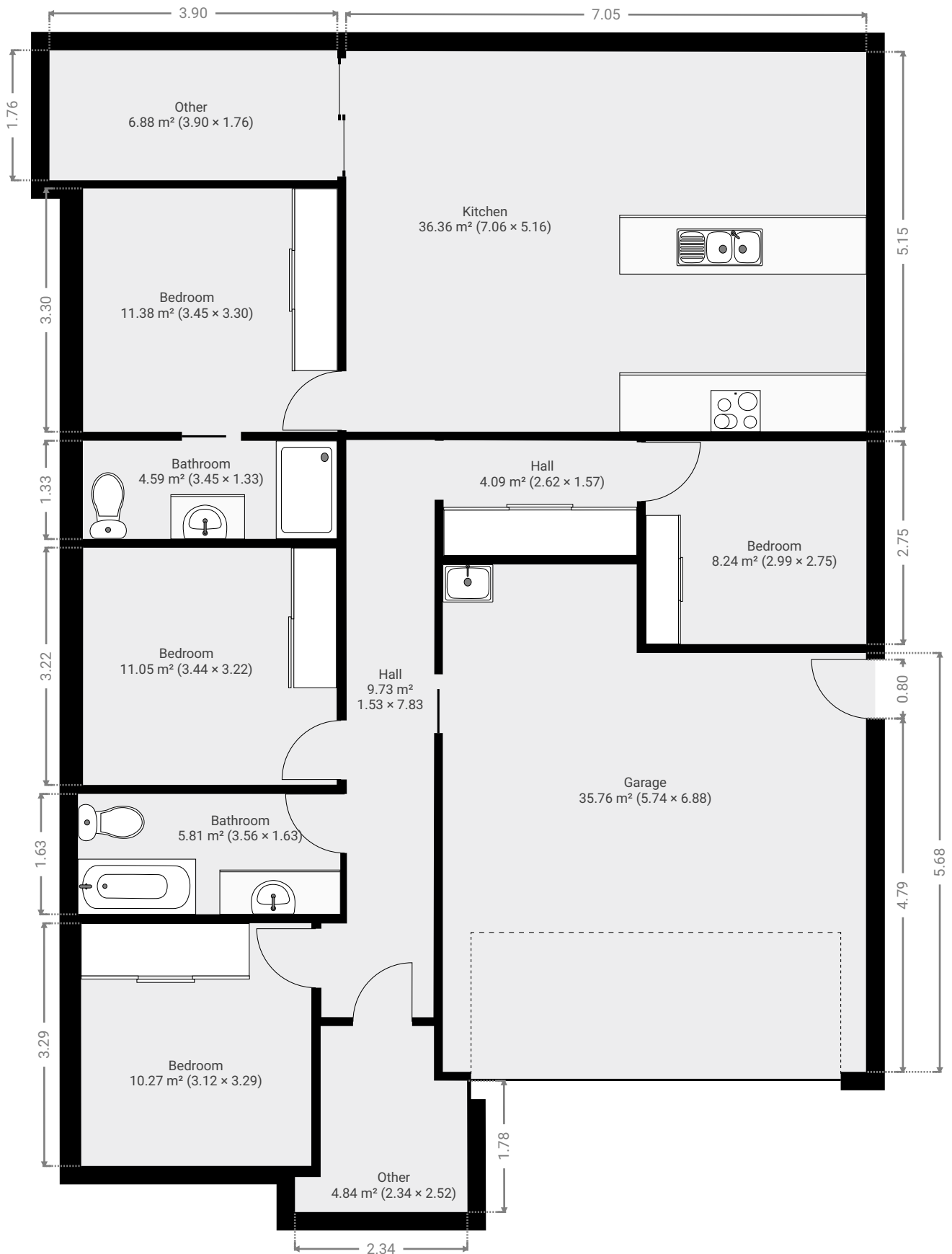

▼ **Bathroom**  
Ground Floor

WIDTH: 3.56 m • LENGTH: 1.63 m  
AREA: 5.81 m<sup>2</sup> • PERIMETER: 10.38 m

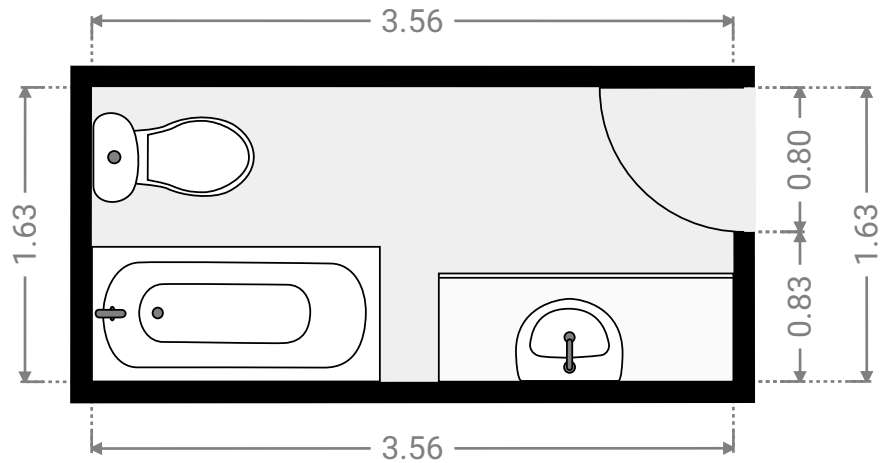
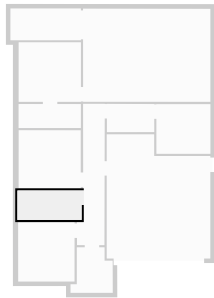

▼ **Bathroom**  
Ground Floor

WIDTH: 3.45 m • LENGTH: 1.33 m  
AREA: 4.59 m<sup>2</sup> • PERIMETER: 9.56 m

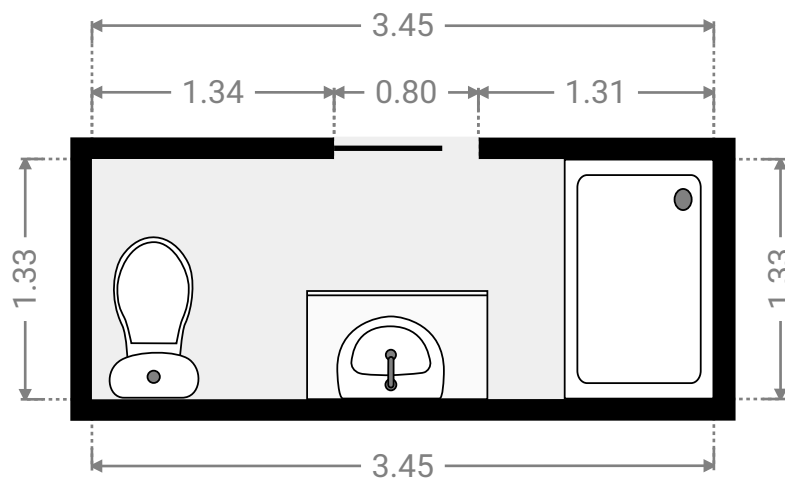
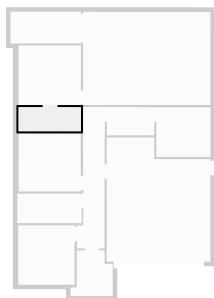

▼ **Bedroom**  
Ground Floor

WIDTH: 3.12 m • LENGTH: 3.29 m  
AREA: 10.27 m<sup>2</sup> • PERIMETER: 12.82 m

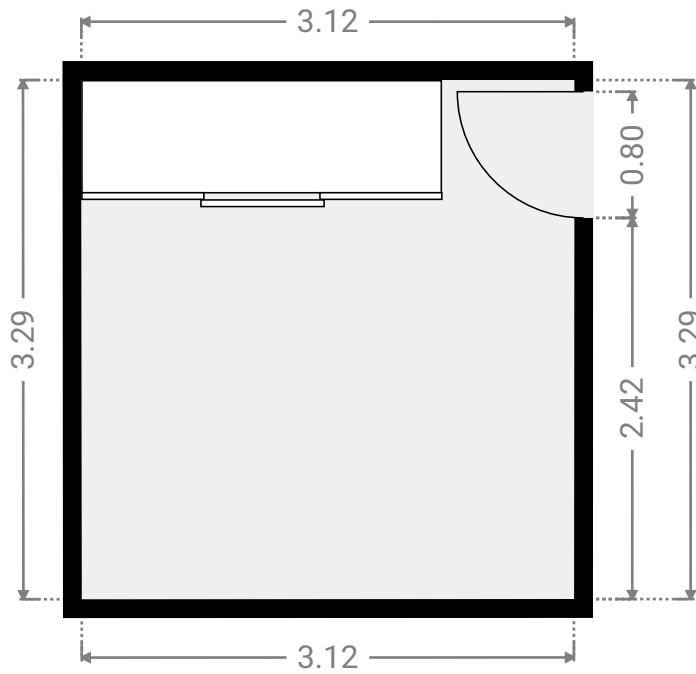
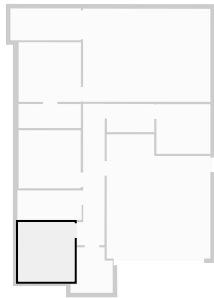

▼ **Bedroom**  
Ground Floor

WIDTH: 3.44 m • LENGTH: 3.22 m  
AREA: 11.05 m<sup>2</sup> • PERIMETER: 13.31 m

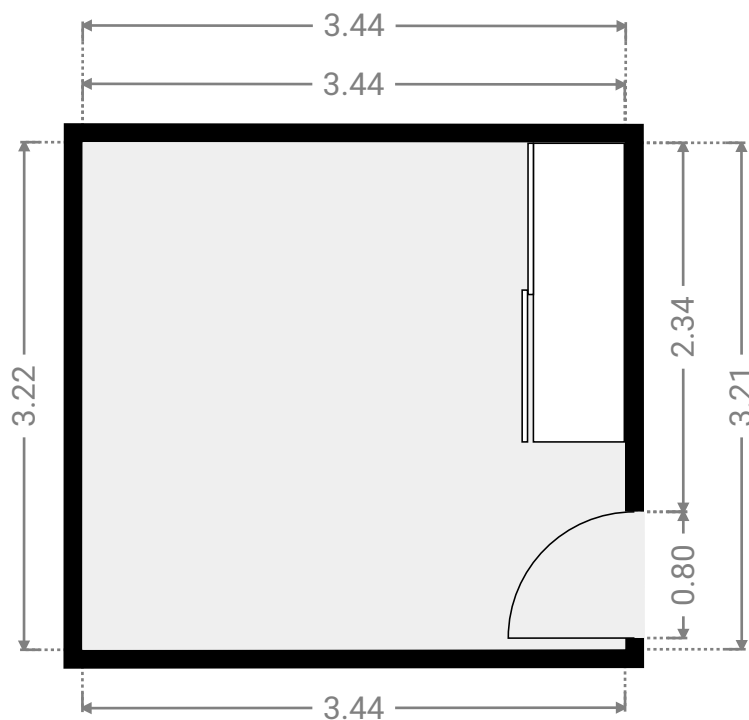
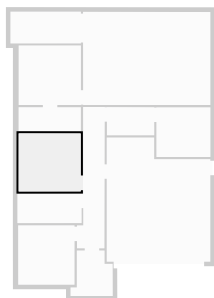

▼ **Bedroom**  
Ground Floor

WIDTH: 3.45 m • LENGTH: 3.30 m  
AREA: 11.38 m<sup>2</sup> • PERIMETER: 13.50 m

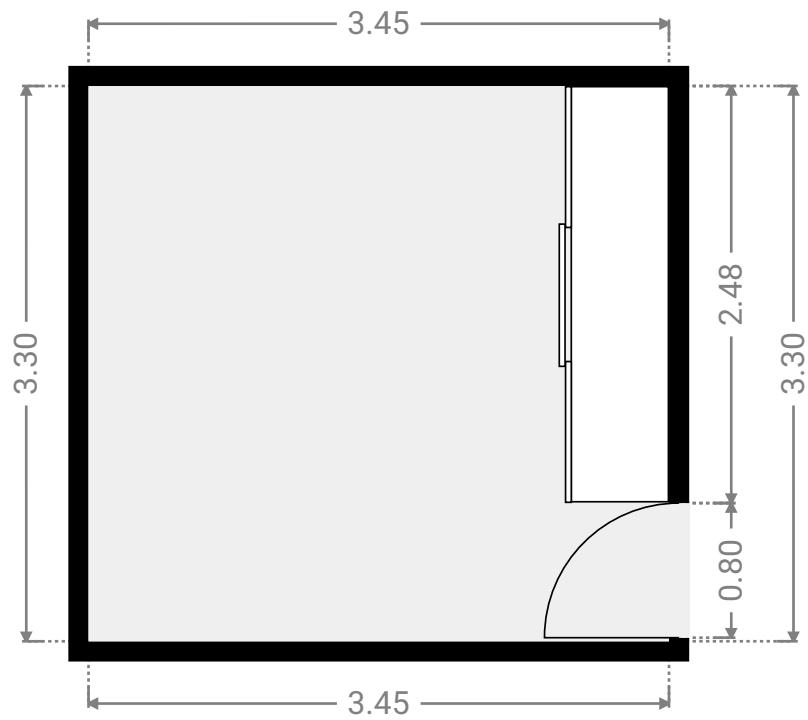
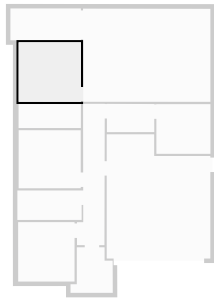

▼ **Bedroom**  
Ground Floor

WIDTH: 2.99 m • LENGTH: 2.75 m  
AREA: 8.24 m<sup>2</sup> • PERIMETER: 11.49 m

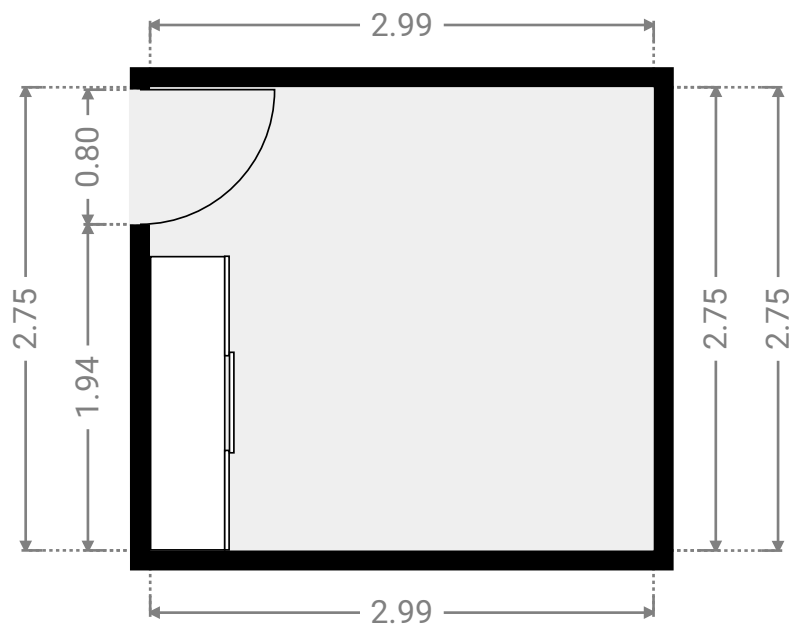
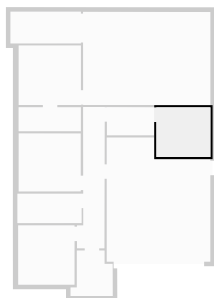

FLOORS: 1

## ▼ Garage Ground Floor

WIDTH: 5.74 m • LENGTH: 6.88 m  
AREA: 35.76 m<sup>2</sup> • PERIMETER: 25.24 m

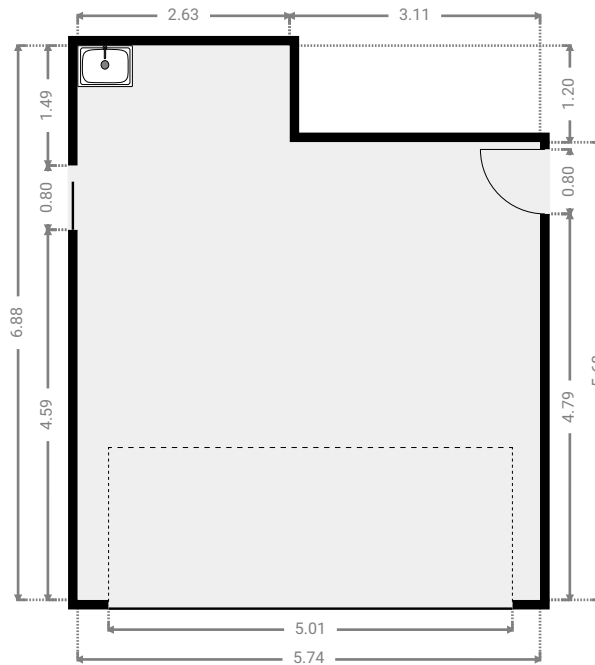
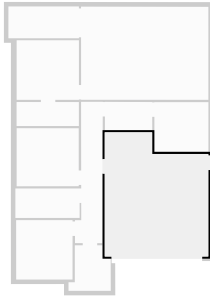

## ▼ Hall Ground Floor

WIDTH: 1.53 m • LENGTH: 7.83 m  
AREA: 9.73 m<sup>2</sup> • PERIMETER: 18.72 m

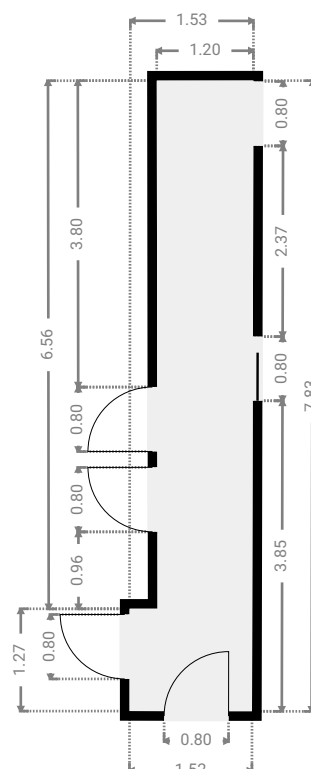
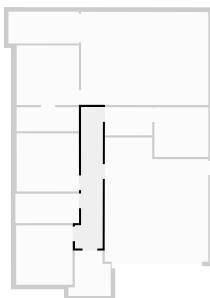

## ▼ Hall Ground Floor

WIDTH: 2.62 m • LENGTH: 1.57 m  
AREA: 4.09 m<sup>2</sup> • PERIMETER: 8.37 m

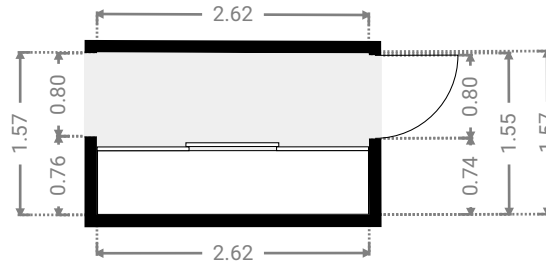
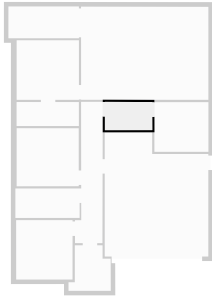

## ▼ Kitchen Ground Floor

WIDTH: 7.06 m • LENGTH: 5.16 m  
AREA: 36.36 m<sup>2</sup> • PERIMETER: 24.42 m

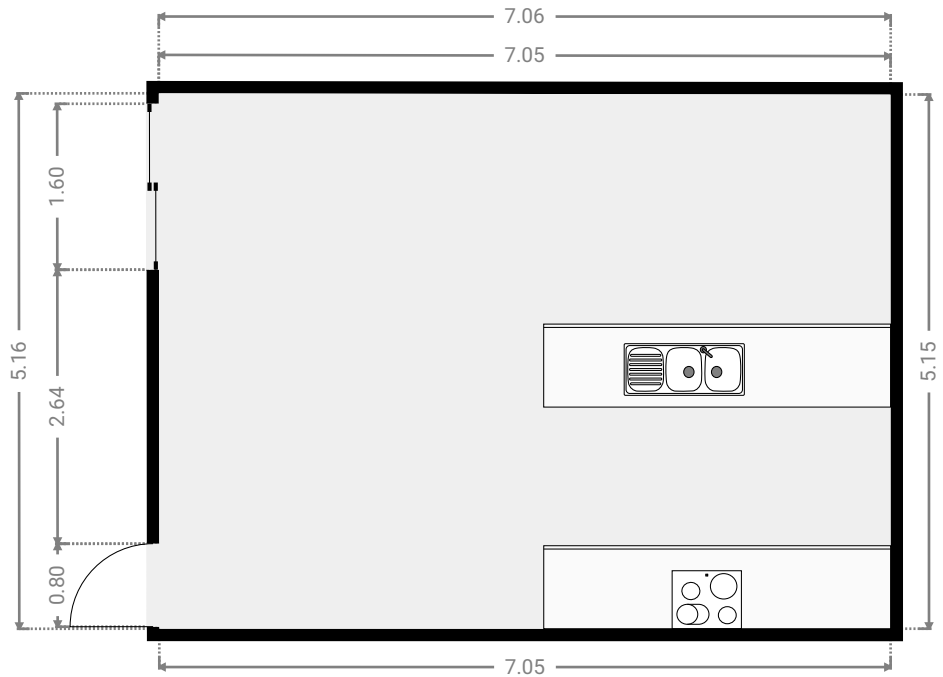
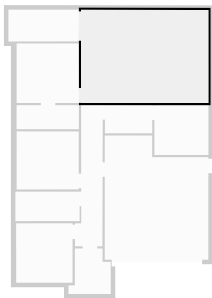

▼ Other  
Ground Floor

WIDTH: 3.90 m • LENGTH: 1.76 m  
AREA: 6.88 m<sup>2</sup> • PERIMETER: 11.33 m

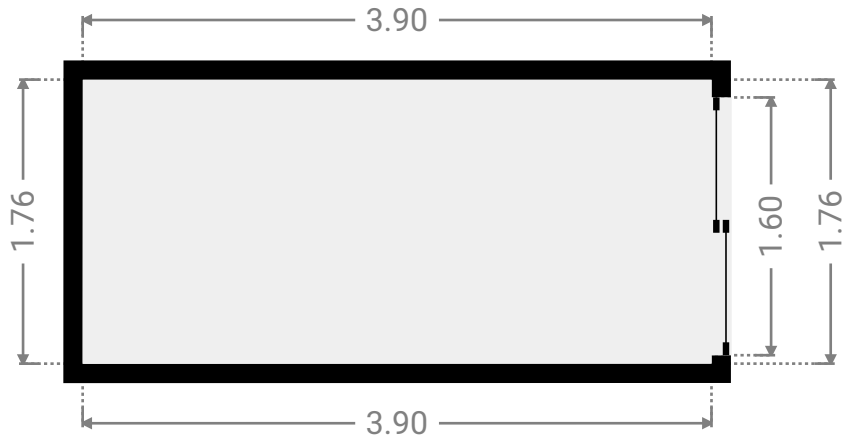
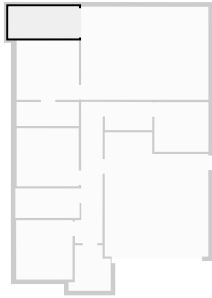

▼ Other  
Ground Floor

WIDTH: 2.34 m • LENGTH: 2.52 m  
AREA: 4.84 m<sup>2</sup> • PERIMETER: 9.72 m

