

246 Elphinstone Street

Created on
2017-08-08

Floors
2

▼ Ground Floor

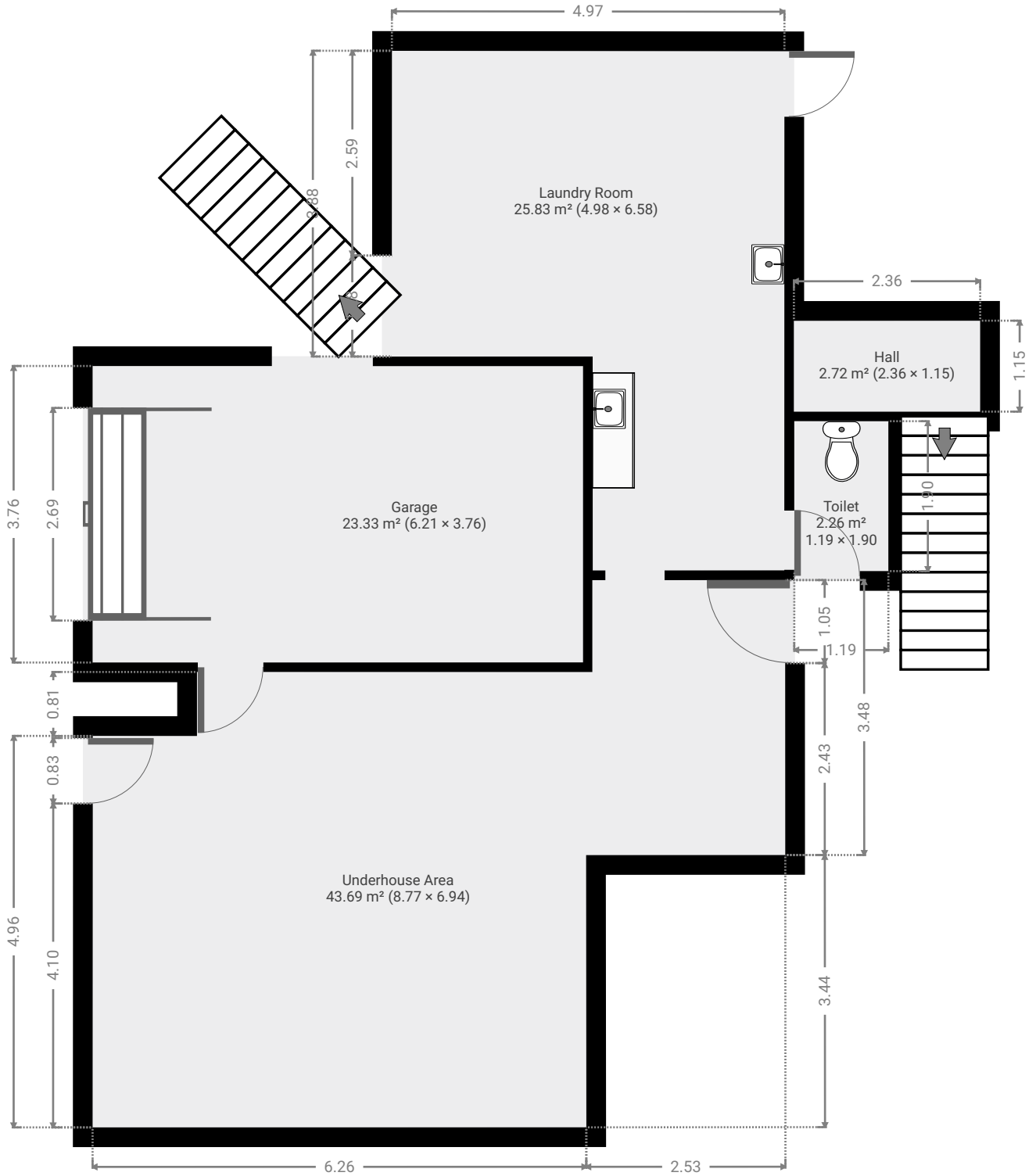

▼ Laundry Room
Ground Floor

WIDTH: 6.57 m • LENGTH: 4.97 m
AREA: 25.83 m² • PERIMETER: 23.11 m

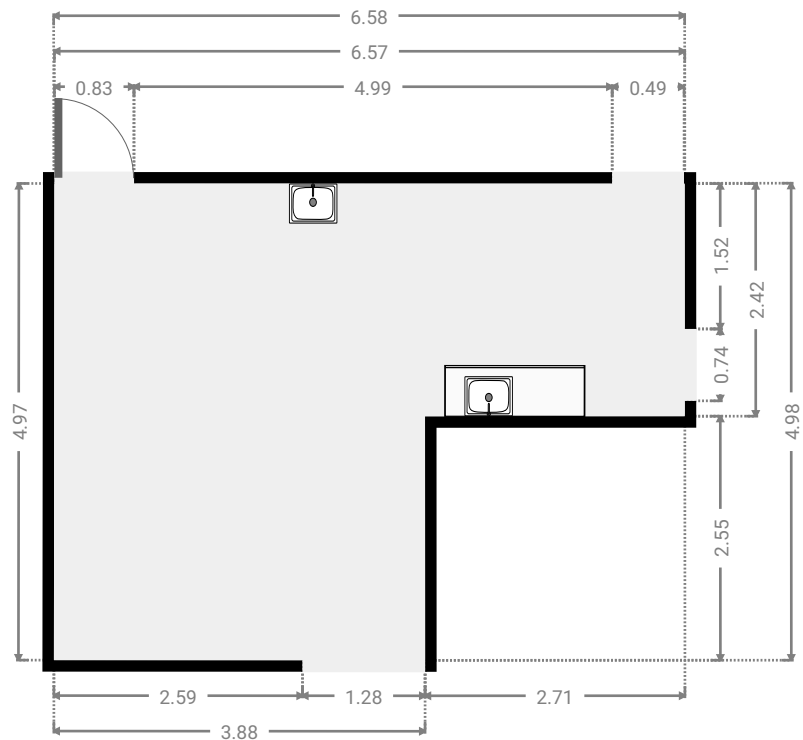
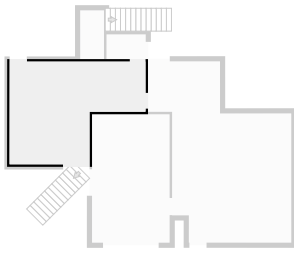

▼ Toilet
Ground Floor

WIDTH: 1.90 m • LENGTH: 1.19 m
AREA: 2.26 m² • PERIMETER: 6.18 m

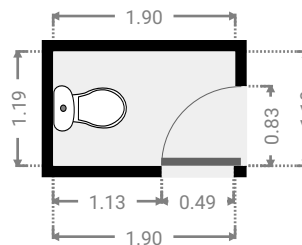
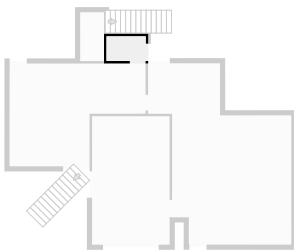

▼ Underhouse Area
Ground Floor

WIDTH: 6.94 m • LENGTH: 8.77 m
AREA: 43.69 m² • PERIMETER: 31.42 m

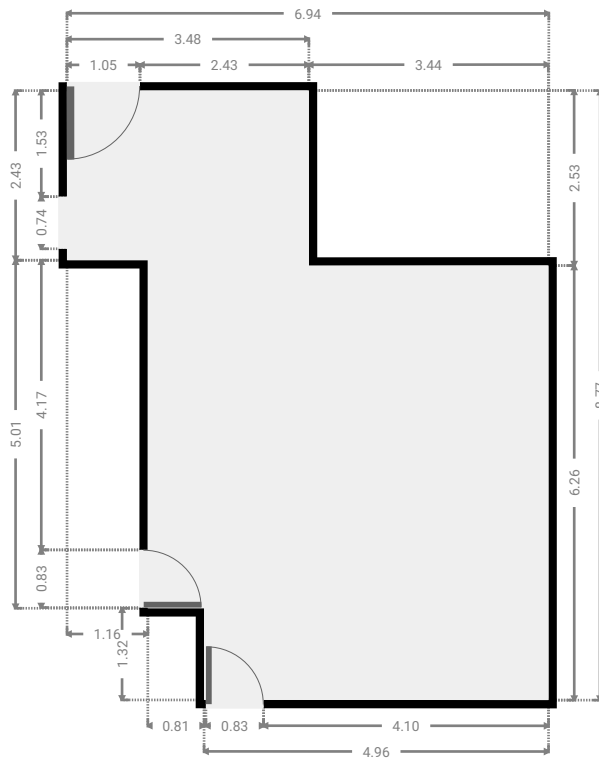
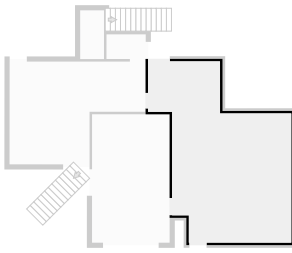

▼ Garage
Ground Floor

WIDTH: 3.76 m • LENGTH: 6.21 m
AREA: 23.33 m² • PERIMETER: 19.94 m

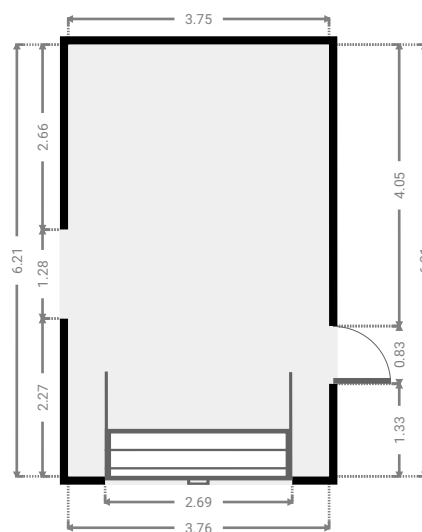
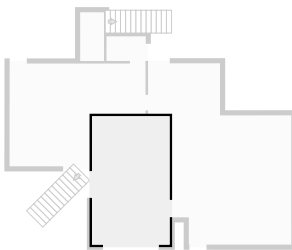

▼ **Hall**
Ground Floor

WIDTH: 1.15 m • LENGTH: 2.36 m
AREA: 2.72 m² • PERIMETER: 7.02 m

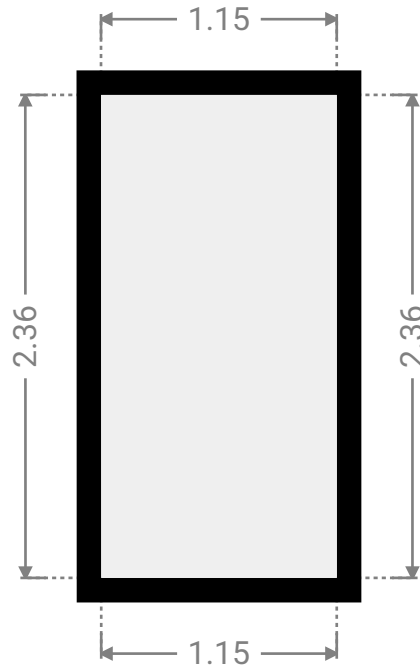
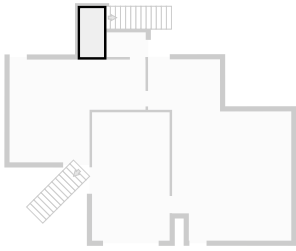

▼ 1st Floor



▼ Kitchen
1st Floor

WIDTH: 3.65 m • LENGTH: 4.86 m
AREA: 17.73 m² • PERIMETER: 17.02 m

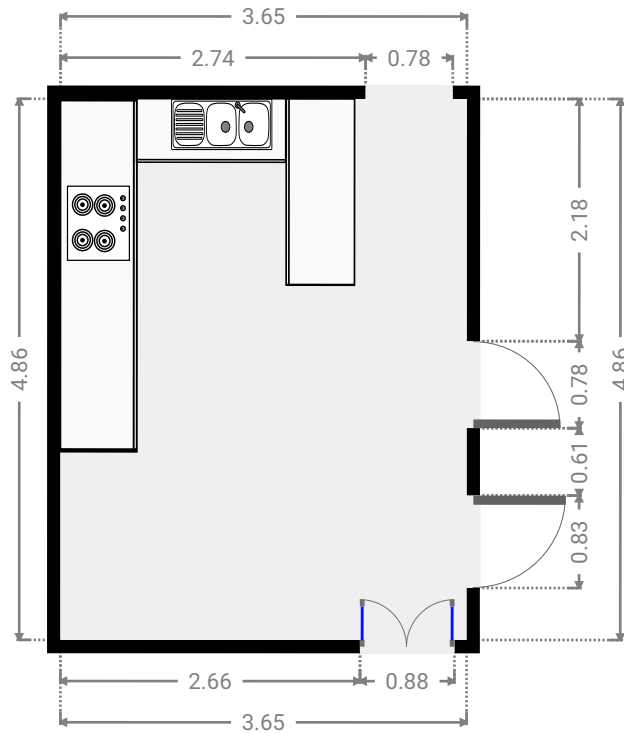
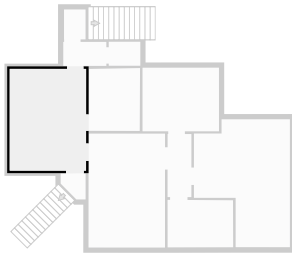

▼ Living Room
1st Floor

WIDTH: 3.65 m • LENGTH: 5.44 m
AREA: 19.87 m² • PERIMETER: 18.18 m

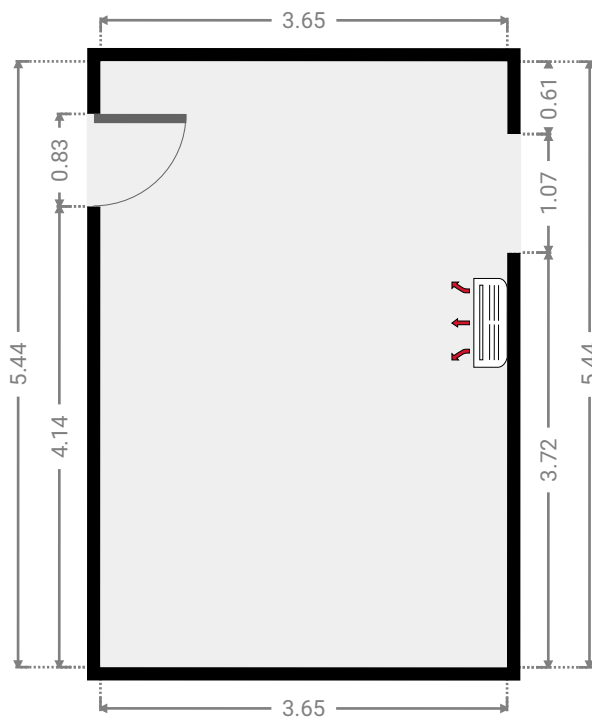
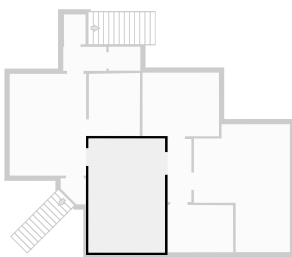

▼ Bathroom
1st Floor

WIDTH: 2.44 m • LENGTH: 3.01 m
AREA: 7.26 m² • PERIMETER: 10.84 m

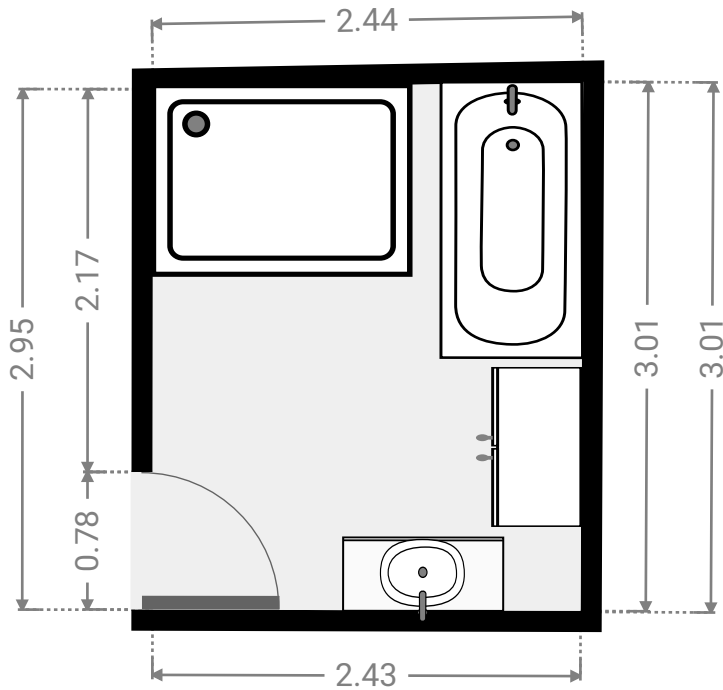
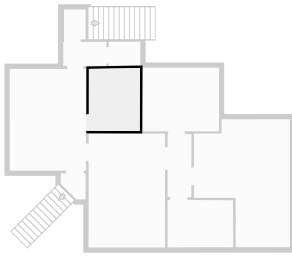

▼ Hall
1st Floor

WIDTH: 2.06 m • LENGTH: 1.15 m
AREA: 2.36 m² • PERIMETER: 6.41 m

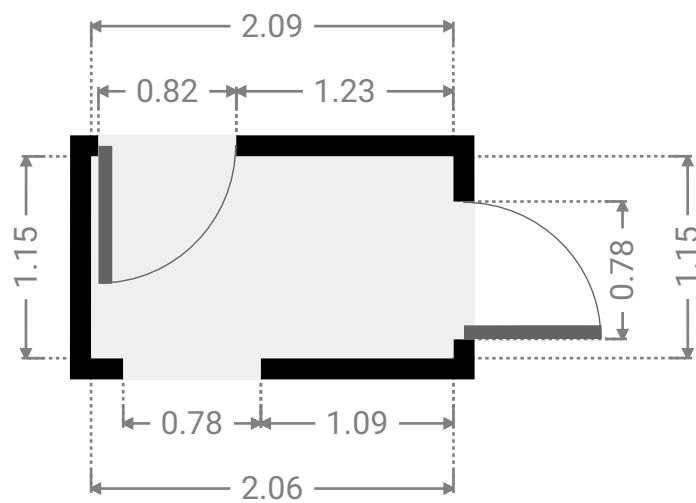
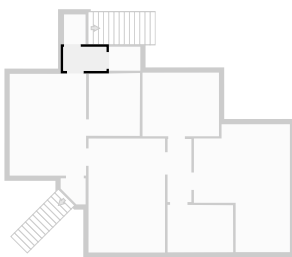

▼ **Toilet**
1st Floor

WIDTH: 1.51 m • LENGTH: 1.15 m
AREA: 1.73 m² • PERIMETER: 5.31 m

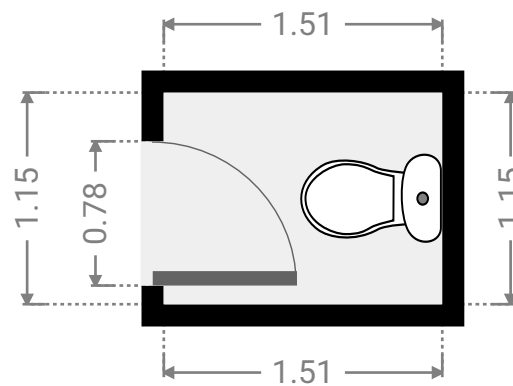
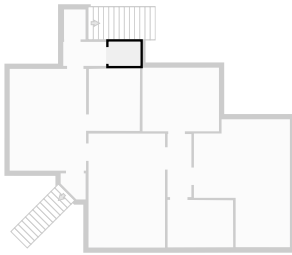

▼ **Hall**
1st Floor

WIDTH: 1.03 m • LENGTH: 1.43 m
AREA: 1.47 m² • PERIMETER: 4.91 m

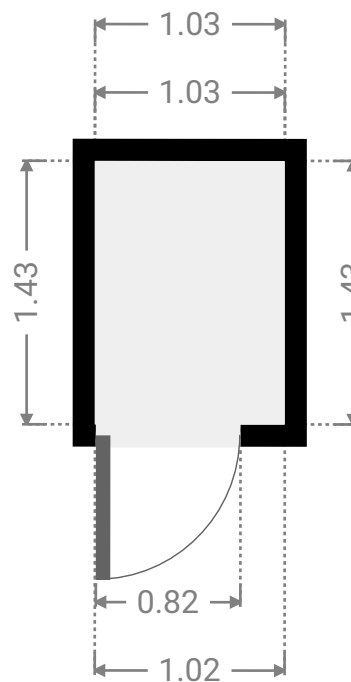
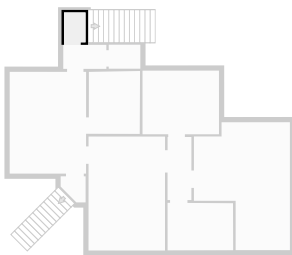

▼ **Hall**
1st Floor

WIDTH: 1.14 m • LENGTH: 3.00 m
AREA: 3.42 m² • PERIMETER: 8.30 m

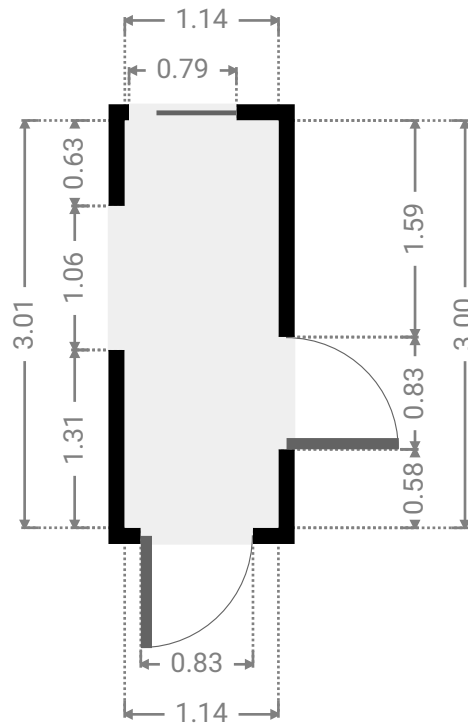
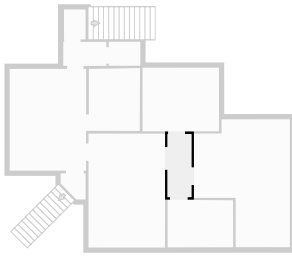

▼ **Bedroom**
1st Floor

WIDTH: 3.65 m • LENGTH: 3.05 m
AREA: 11.09 m² • PERIMETER: 13.38 m

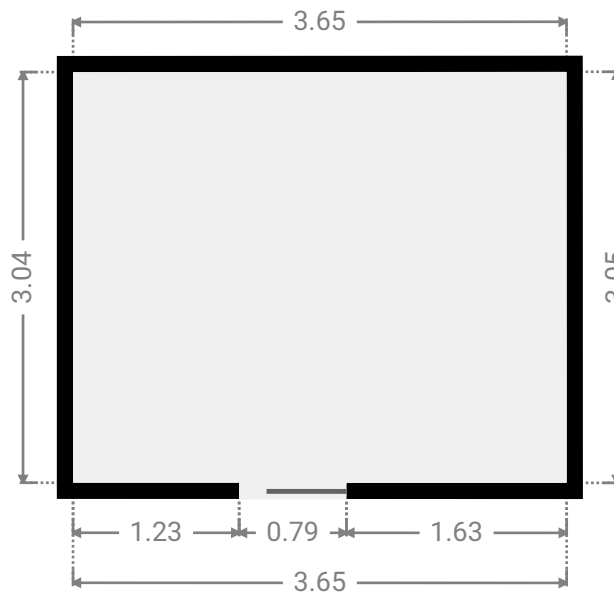
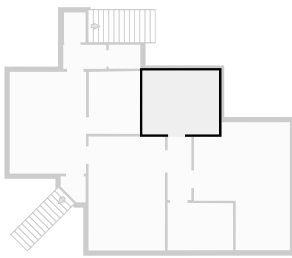

▼ **Master Bedroom**
1st Floor

WIDTH: 4.58 m • LENGTH: 6.11 m
AREA: 22.40 m² • PERIMETER: 21.38 m

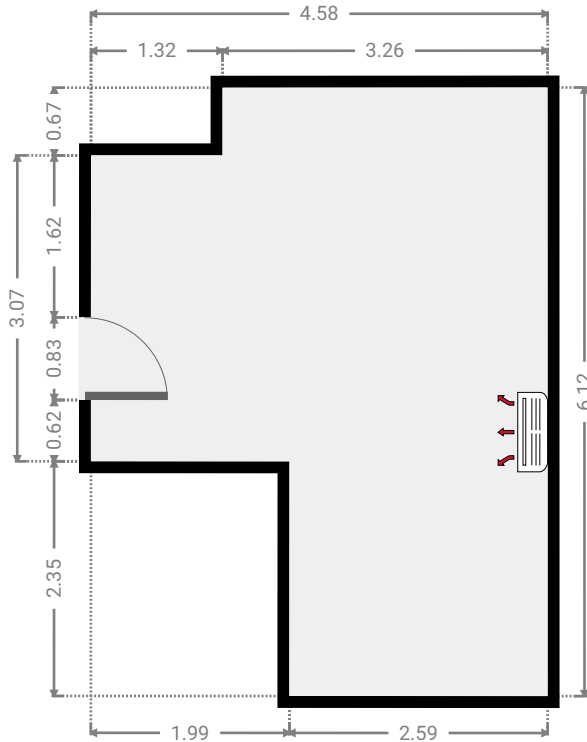
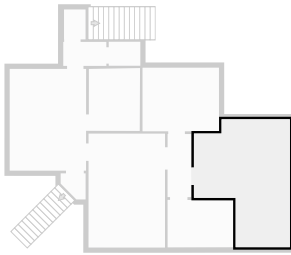

▼ **Bedroom**
1st Floor

WIDTH: 3.13 m • LENGTH: 2.28 m
AREA: 7.06 m² • PERIMETER: 10.77 m

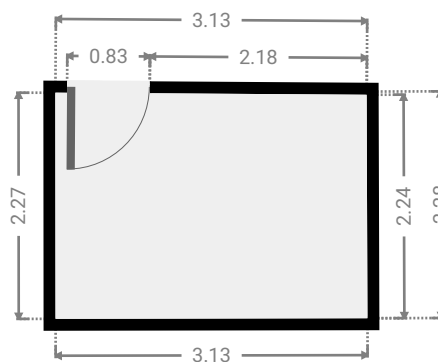
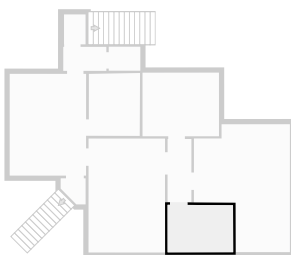

▼ **Entry**
1st Floor

WIDTH: 1.19 m • LENGTH: 1.25 m
AREA: 1.20 m² • PERIMETER: 4.43 m

