

244 Clanfield Street

Ground Floor

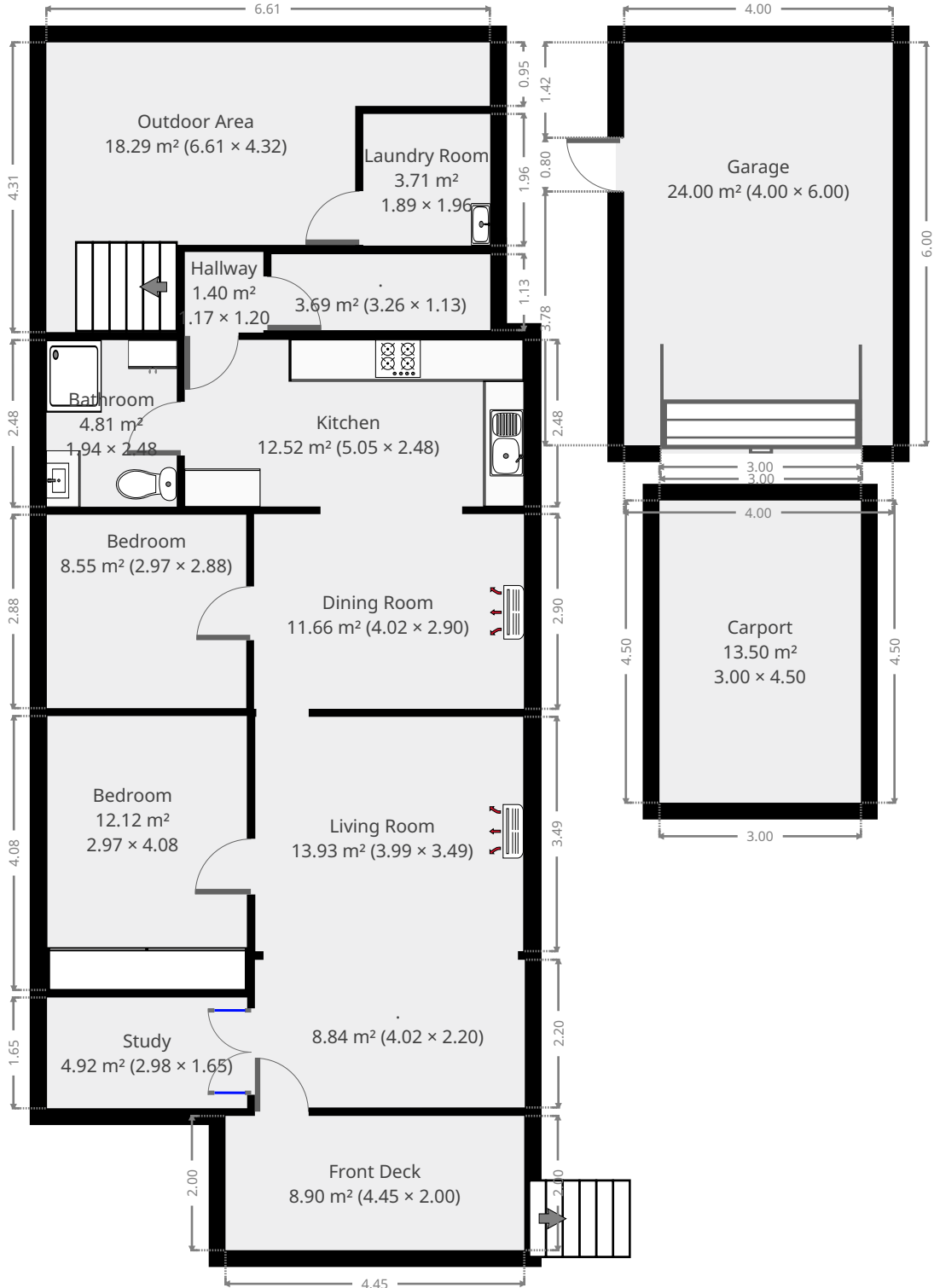

THIS FLOORPLAN IS PROVIDED WITHOUT WARRANTY OF ANY KIND. SENSOPIA DISCLAIMS ANY WARRANTY INCLUDING, WITHOUT LIMITATION, SATISFACTORY QUALITY OR ACCURACY OF DIMENSIONS.



244 Clanfield Street

Width: 2.20 m
 Length: 4.02 m
 Area: 8.84 m²
 Perimeter: 12.44 m

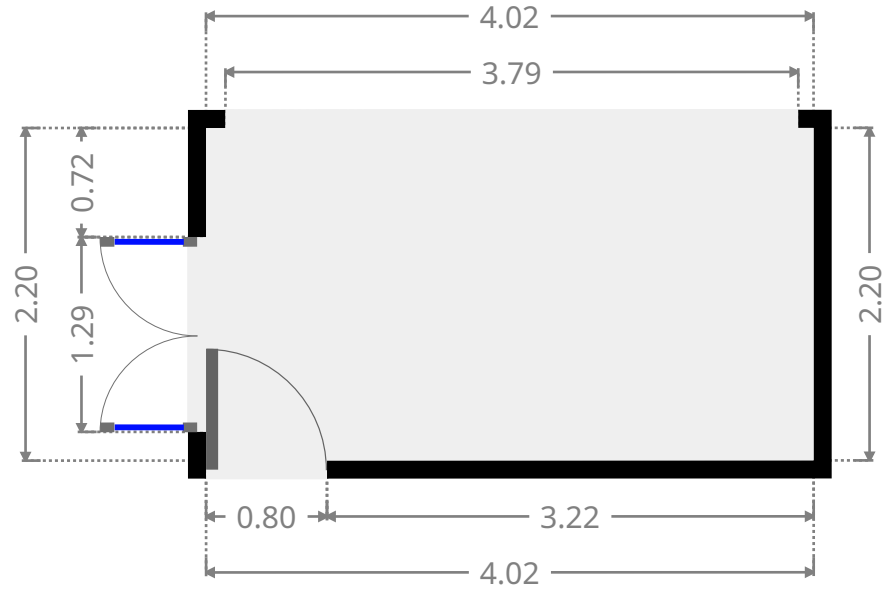
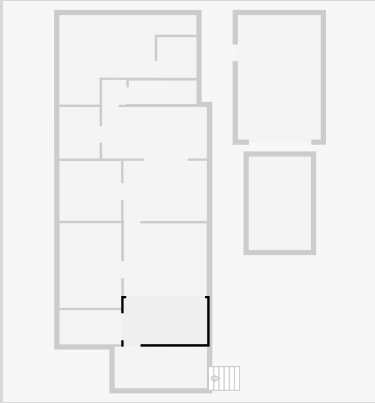

Living Room

Width: 3.49 m
 Length: 3.99 m
 Area: 13.93 m²
 Perimeter: 14.96 m

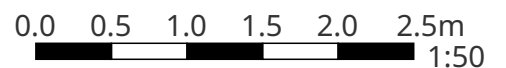
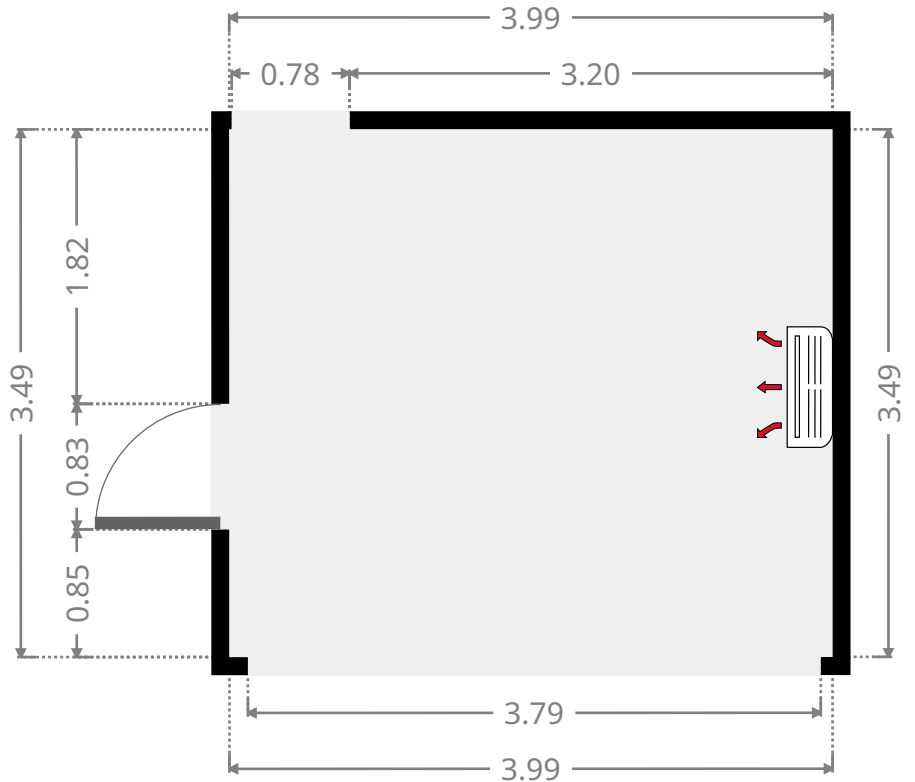
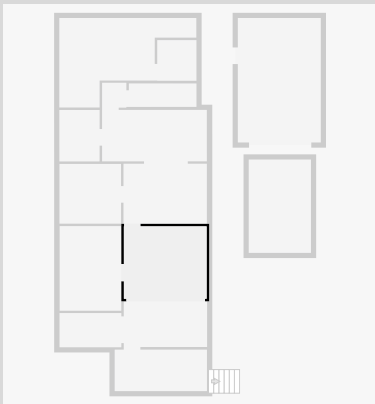

THIS FLOORPLAN IS PROVIDED WITHOUT WARRANTY OF ANY KIND. SENSOPIA DISCLAIMS ANY WARRANTY INCLUDING, WITHOUT LIMITATION, SATISFACTORY QUALITY OR ACCURACY OF DIMENSIONS.

244 Clanfield Street

Study

Width: 1.65 m
Length: 2.98 m
Area: 4.92 m²
Perimeter: 9.26 m

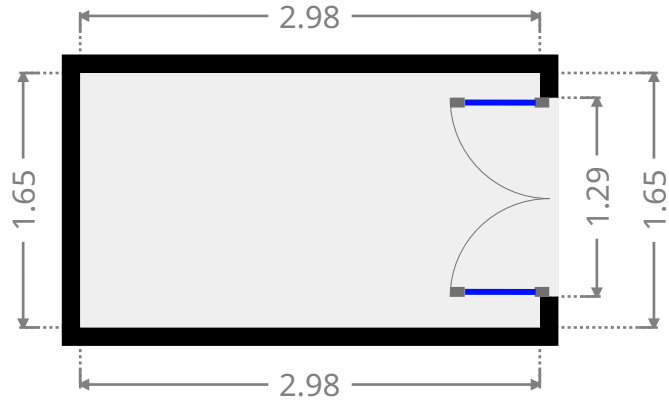
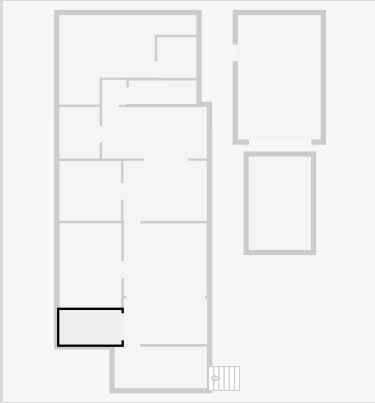

Bedroom

Width: 2.97 m
Length: 4.08 m
Area: 12.12 m²
Perimeter: 14.10 m

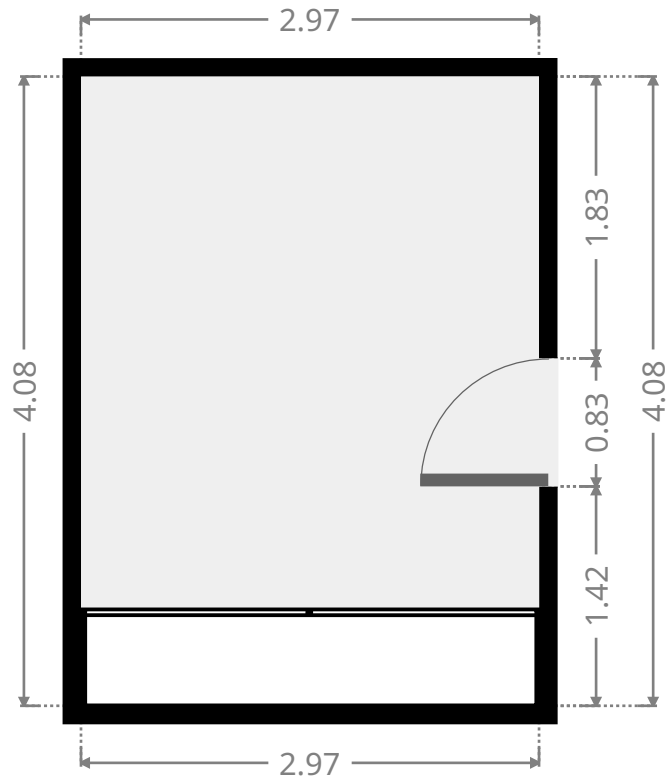
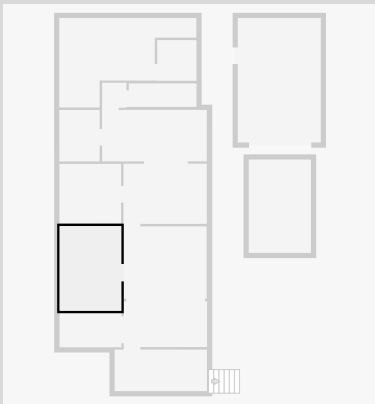

244 Clanfield Street

Dining Room

Width: 2.90 m
 Length: 4.02 m
 Area: 11.66 m²
 Perimeter: 13.84 m

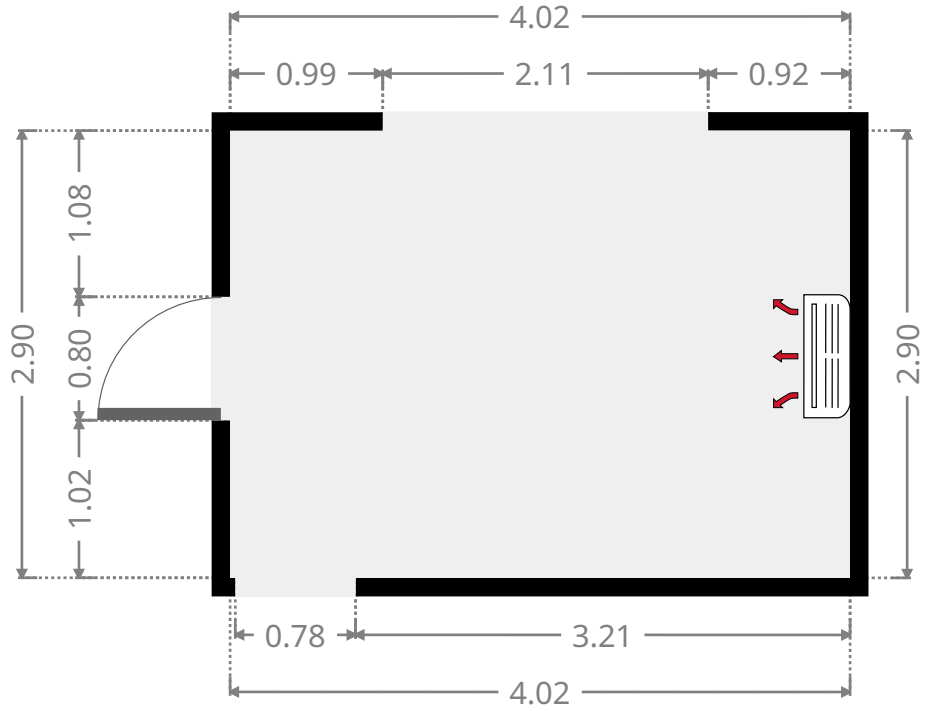
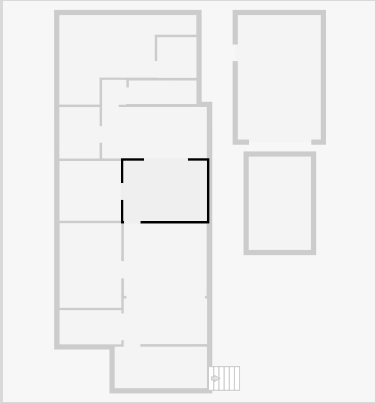

Bedroom

Width: 2.88 m
 Length: 2.97 m
 Area: 8.55 m²
 Perimeter: 11.70 m

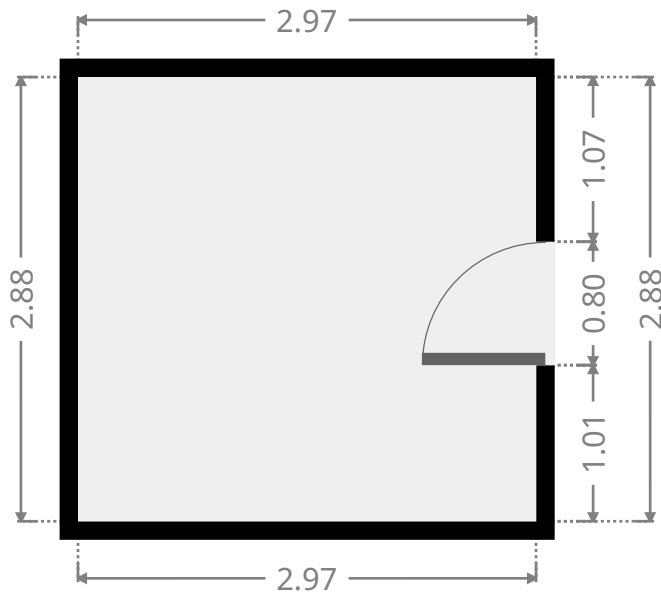
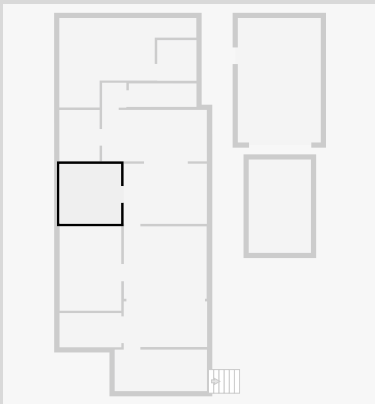

THIS FLOORPLAN IS PROVIDED WITHOUT WARRANTY OF ANY KIND. SENSOPIA DISCLAIMS ANY WARRANTY INCLUDING, WITHOUT LIMITATION, SATISFACTORY QUALITY OR ACCURACY OF DIMENSIONS.

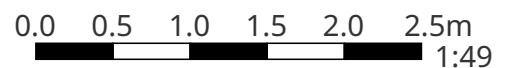

244 Clanfield Street

Kitchen

Width: 2.48 m
Length: 5.05 m
Area: 12.52 m²
Perimeter: 15.06 m

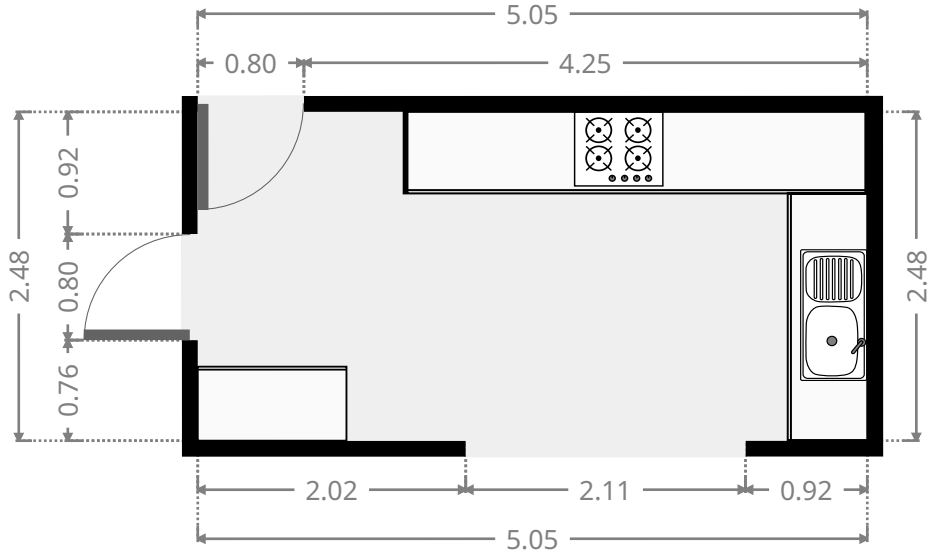
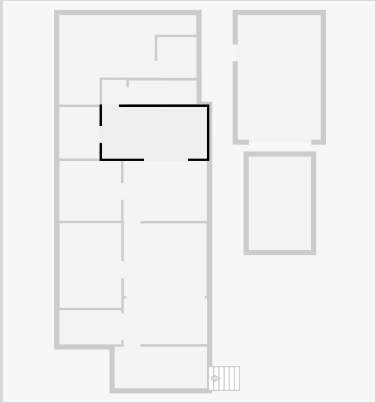

Bathroom

Width: 1.94 m
Length: 2.48 m
Area: 4.81 m²
Perimeter: 8.84 m

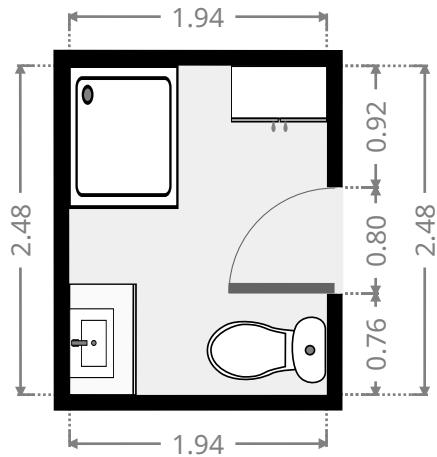
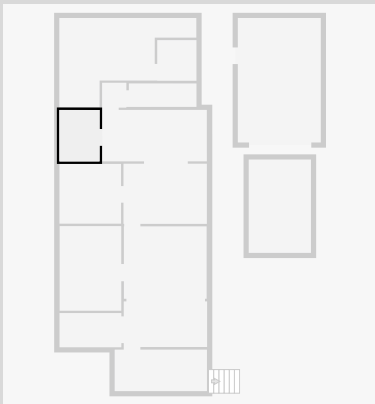

244 Clanfield Street

Hallway

Width: 1.17 m
Length: 1.20 m
Area: 1.40 m²
Perimeter: 4.74 m

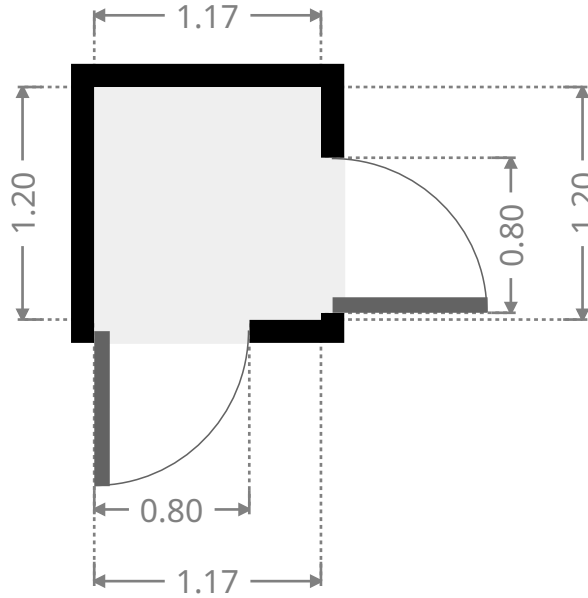
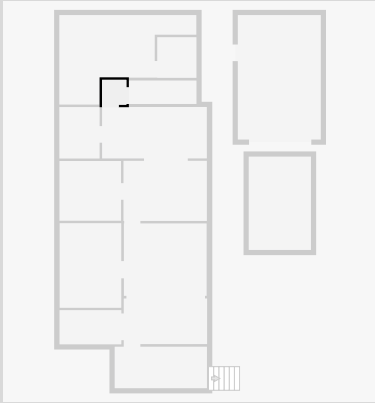

Width: 1.13 m
Length: 3.26 m
Area: 3.69 m²
Perimeter: 8.78 m

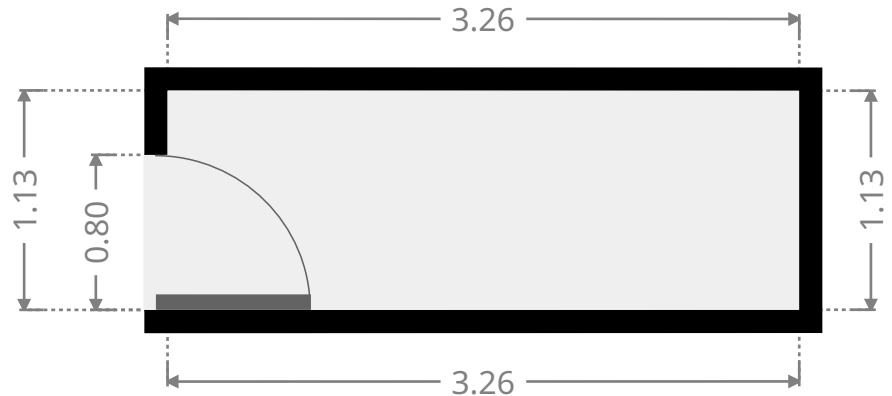
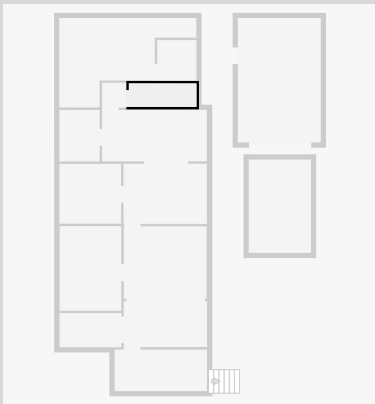

244 Clanfield Street

Outdoor Area

Width: 4.32 m
 Length: 6.61 m
 Area: 18.29 m²
 Perimeter: 21.84 m

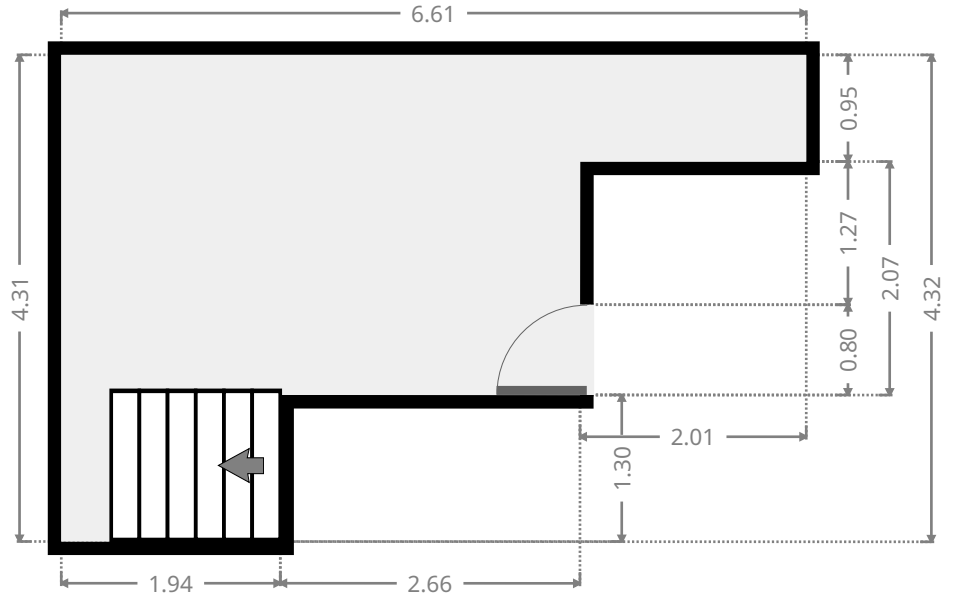
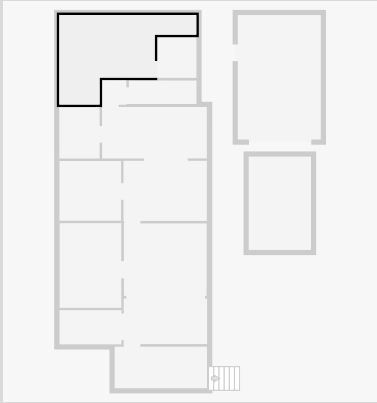

Laundry Room

Width: 1.89 m
 Length: 1.96 m
 Area: 3.71 m²
 Perimeter: 7.70 m

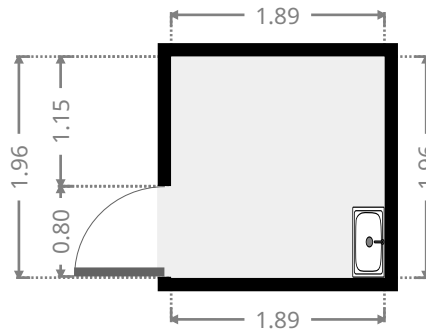
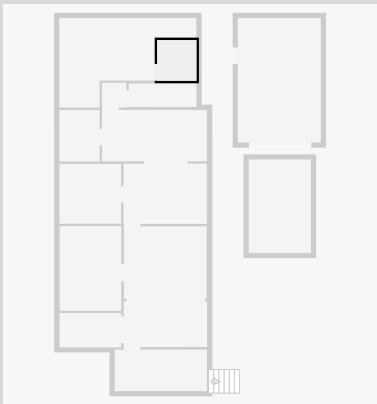

244 Clanfield Street

Garage

Width: 4.00 m
Length: 6.00 m
Area: 24.00 m²
Perimeter: 20.00 m

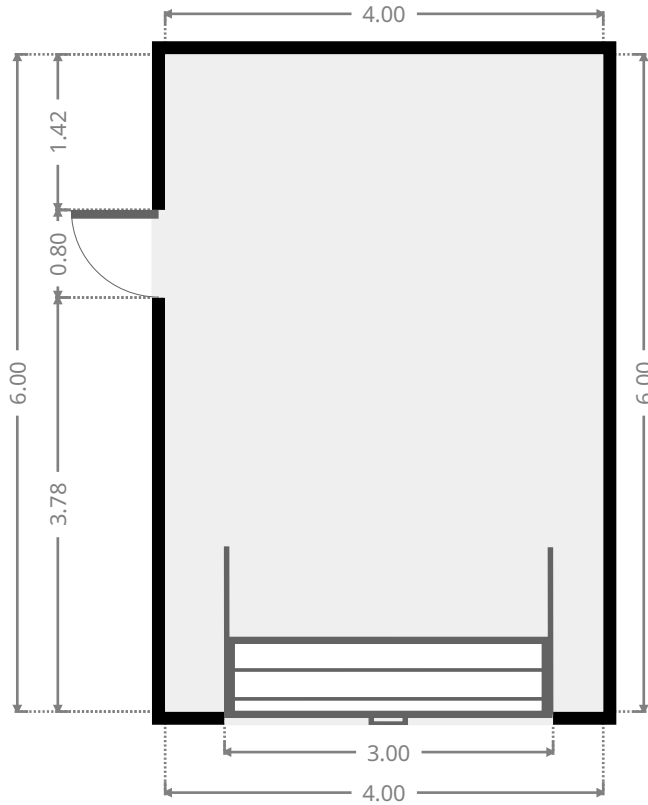
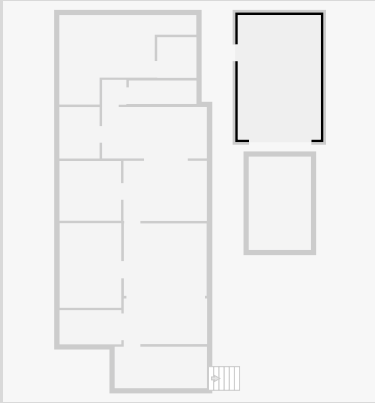

Carport

Width: 3.00 m
Length: 4.50 m
Area: 13.50 m²
Perimeter: 15.00 m

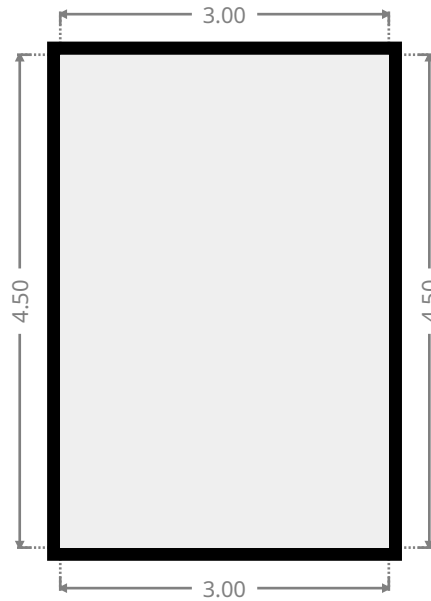
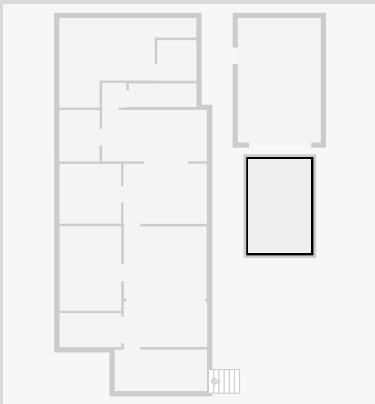

244 Clanfield Street

Front Deck

Width: 2.00 m
Length: 4.45 m
Area: 8.90 m²
Perimeter: 12.90 m

