

243-253 Grubb Street

SUBMITTED BY
Ray White Rockhampton Casey
stockers@cqoz.com

CREATED ON
2022-11-21

Floors
2

▼ Ground Floor

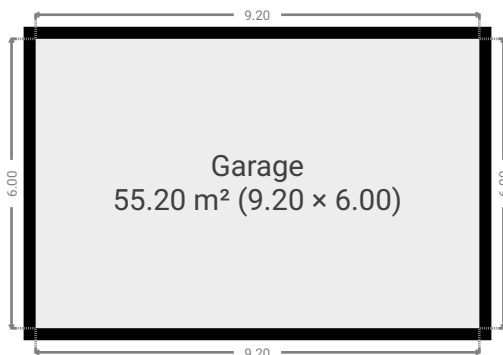
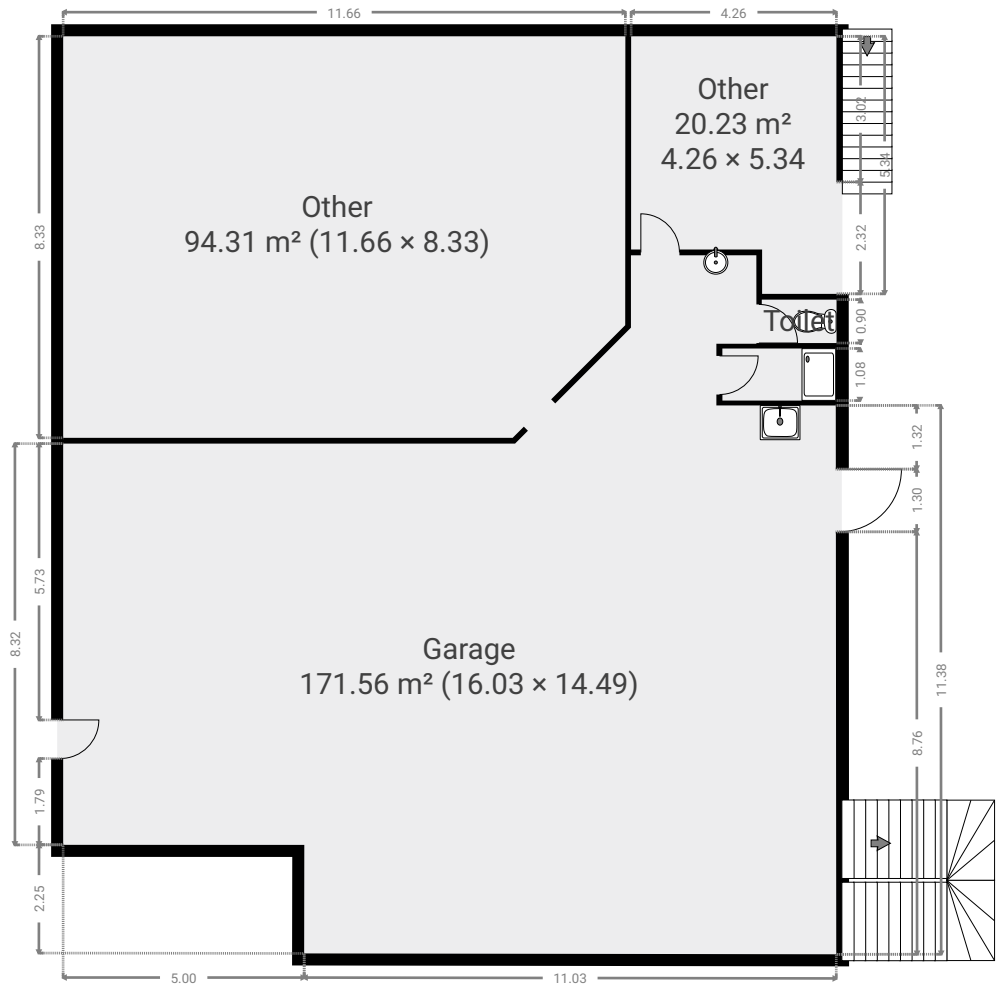

▼ **Bathroom**
Ground Floor

WIDTH: 2.35 m • LENGTH: 1.08 m
AREA: 2.54 m² • PERIMETER: 6.86 m

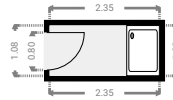
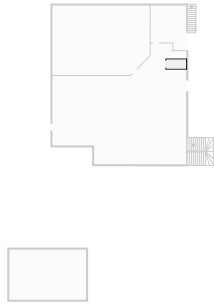

▼ **Garage**
Ground Floor

WIDTH: 16.03 m • LENGTH: 14.49 m
AREA: 171.56 m² • PERIMETER: 61.27 m

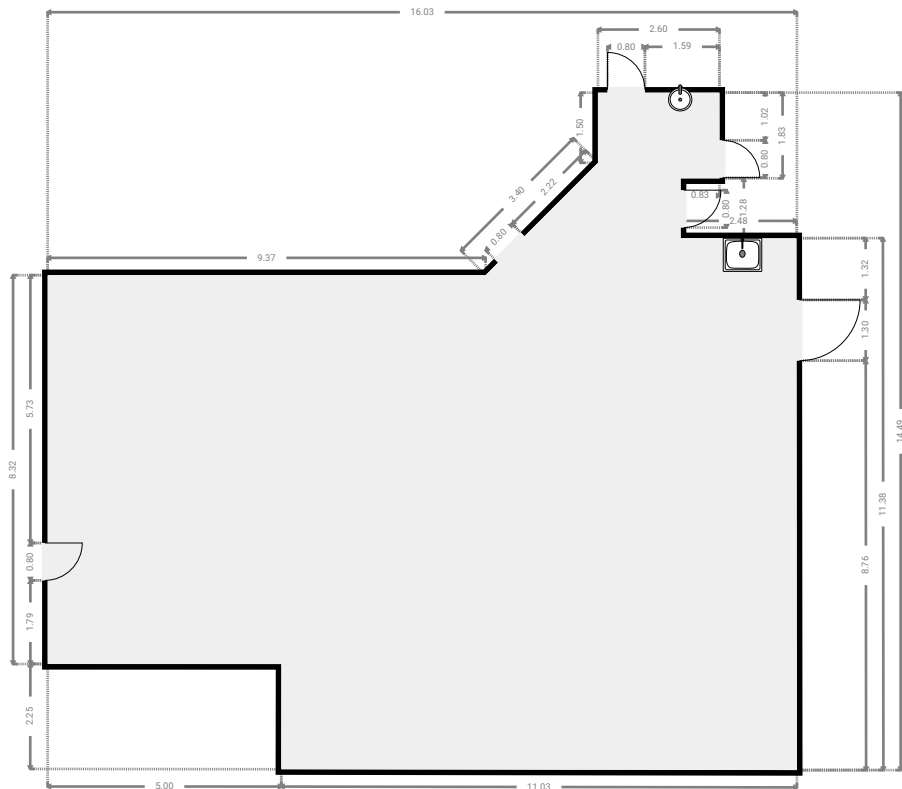
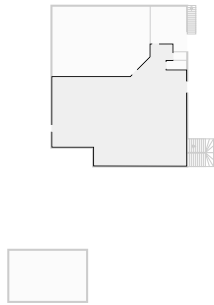

FLOORS: 2

▼ **Garage**
Ground Floor

WIDTH: 9.20 m • LENGTH: 6.00 m
AREA: 55.20 m² • PERIMETER: 30.40 m

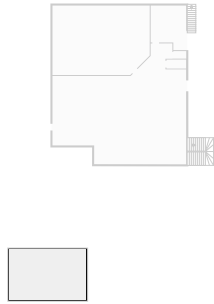

▼ **Other**
Ground Floor

WIDTH: 4.26 m • LENGTH: 5.34 m
AREA: 20.23 m² • PERIMETER: 19.19 m

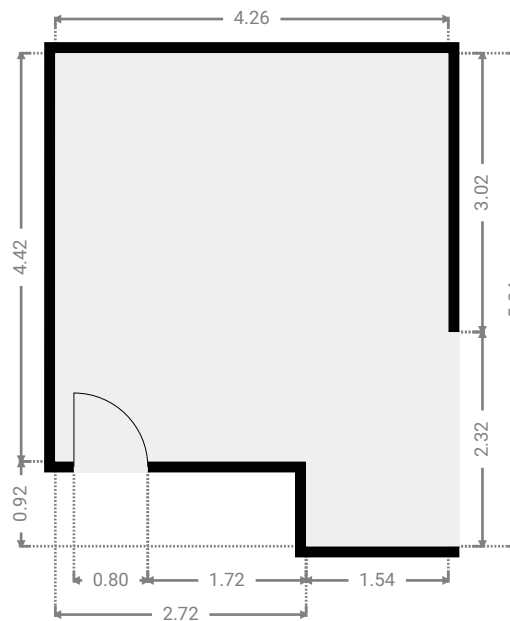
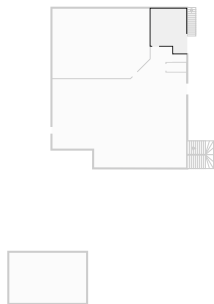

FLOORS: 2

▼ **Other**
Ground Floor

WIDTH: 11.66 m • LENGTH: 8.33 m
AREA: 94.31 m² • PERIMETER: 38.60 m

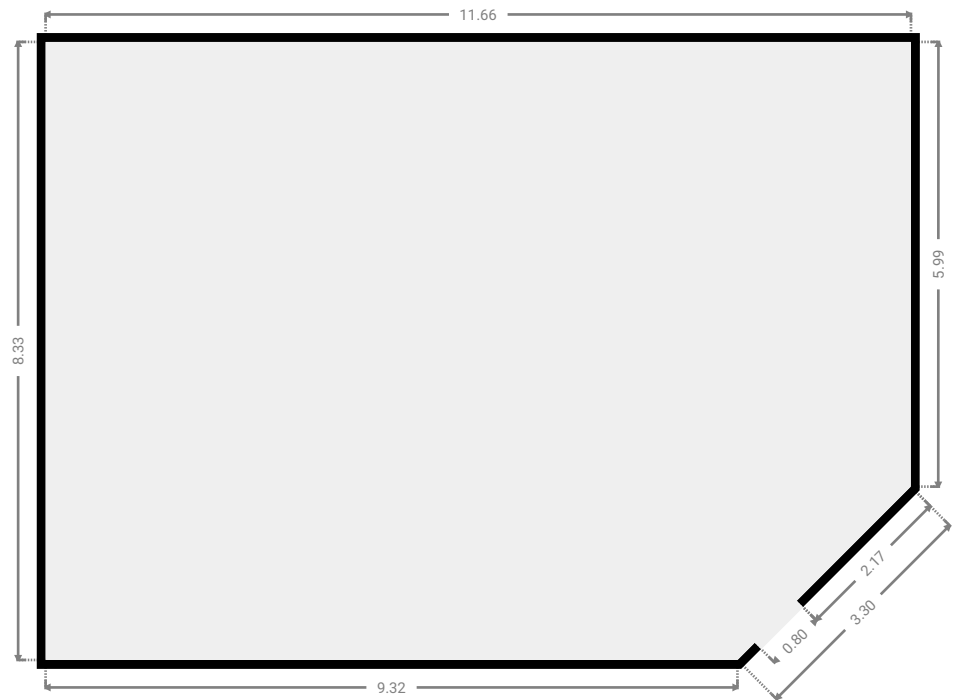
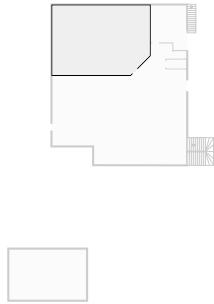

▼ **Toilet**
Ground Floor

WIDTH: 1.55 m • LENGTH: 0.90 m
AREA: 1.40 m² • PERIMETER: 4.90 m

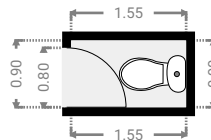
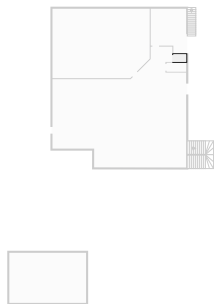

▼ 1st Floor



▼ Bathroom
1st Floor

WIDTH: 2.34 m • LENGTH: 2.50 m
AREA: 5.85 m² • PERIMETER: 9.68 m

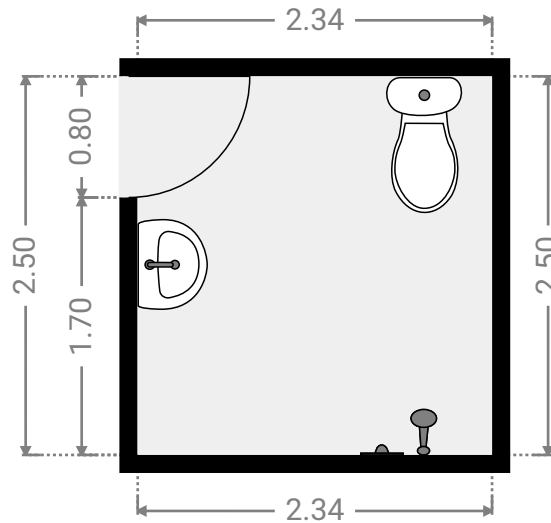
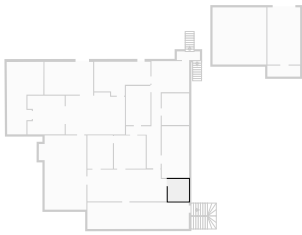

▼ Bathroom
1st Floor

WIDTH: 3.05 m • LENGTH: 3.53 m
AREA: 10.75 m² • PERIMETER: 13.15 m

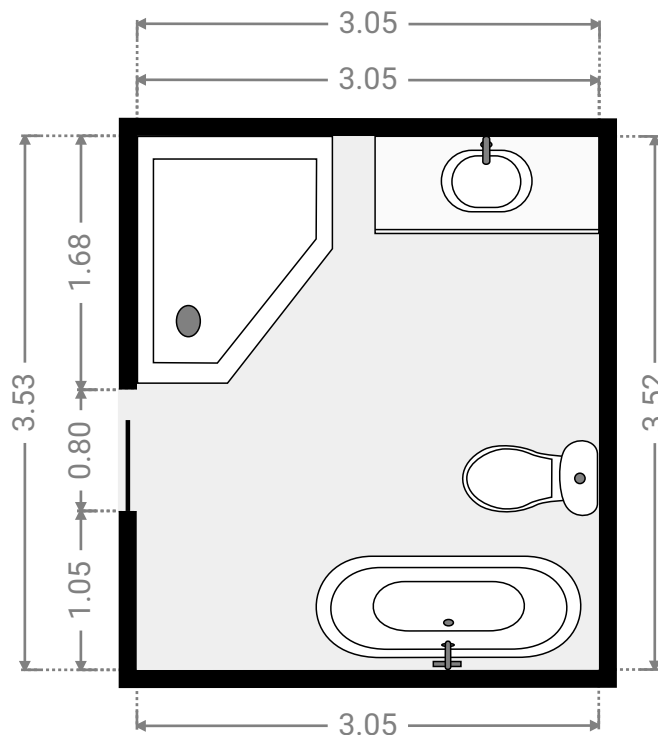
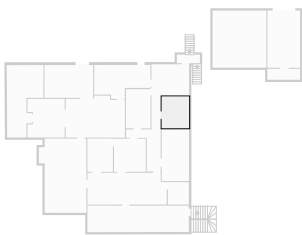

▼ **Bedroom**
1st Floor

WIDTH: 2.84 m • LENGTH: 3.72 m
AREA: 10.56 m² • PERIMETER: 13.12 m

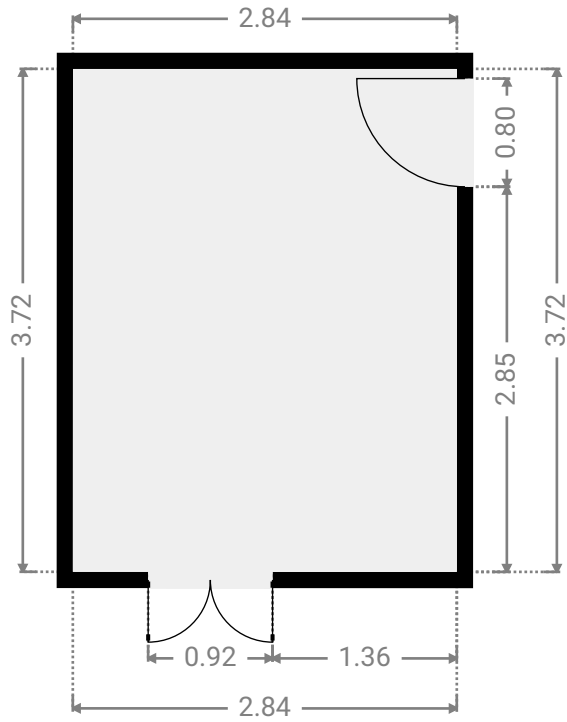
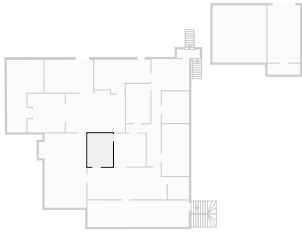

▼ **Bedroom**
1st Floor

WIDTH: 3.54 m • LENGTH: 3.70 m
AREA: 13.10 m² • PERIMETER: 14.48 m

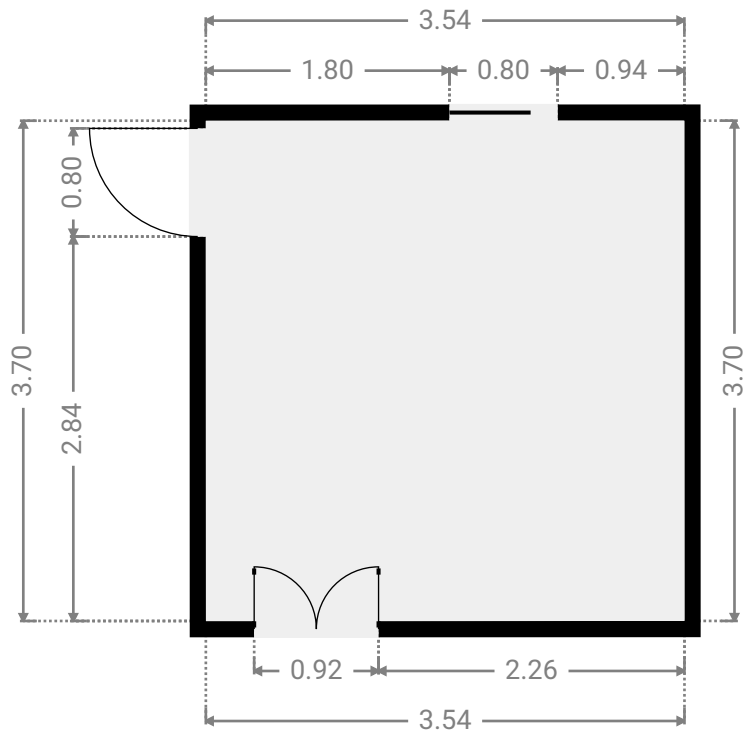
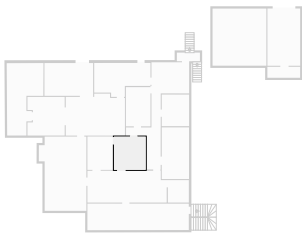

▼ **Bedroom**
1st Floor

WIDTH: 3.04 m • LENGTH: 5.76 m
AREA: 17.52 m² • PERIMETER: 17.60 m

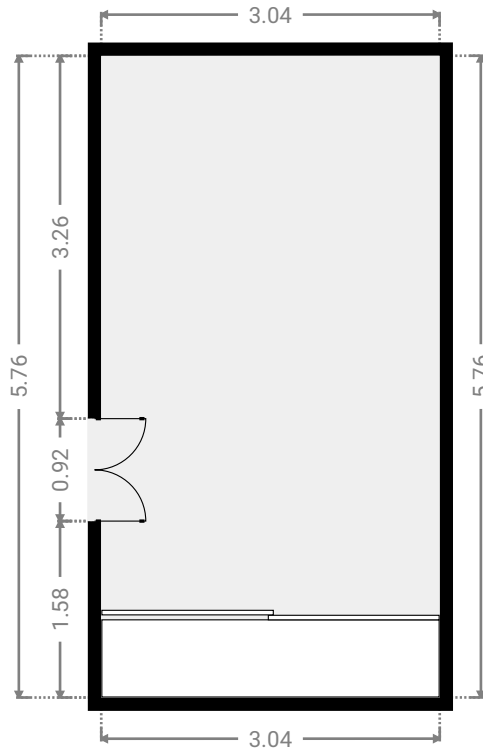
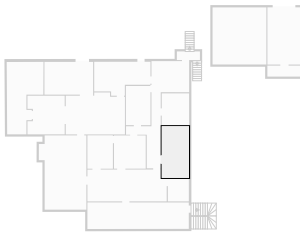

▼ **Bedroom**
1st Floor

WIDTH: 2.74 m • LENGTH: 4.37 m
AREA: 11.97 m² • PERIMETER: 14.22 m

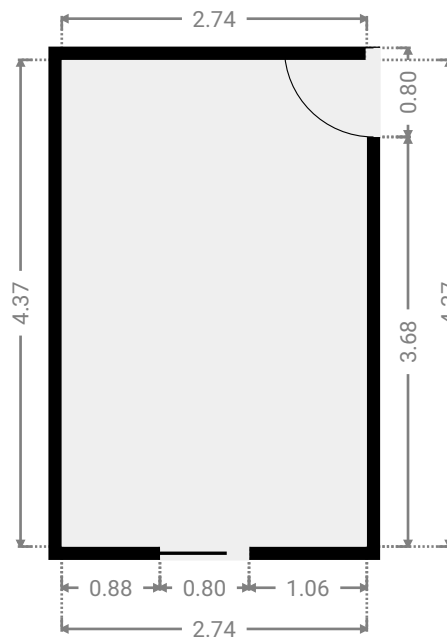
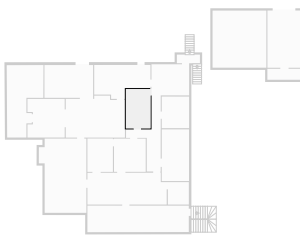

▼ Dining Room
1st Floor

WIDTH: 4.20 m • LENGTH: 3.47 m
AREA: 14.56 m² • PERIMETER: 15.33 m

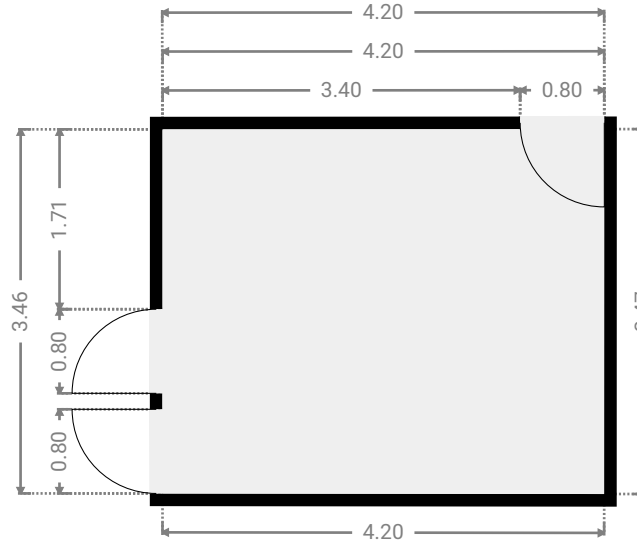
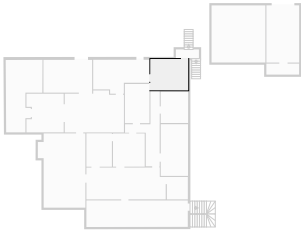

▼ Dining Room
1st Floor

WIDTH: 6.60 m • LENGTH: 4.68 m
AREA: 28.94 m² • PERIMETER: 22.56 m

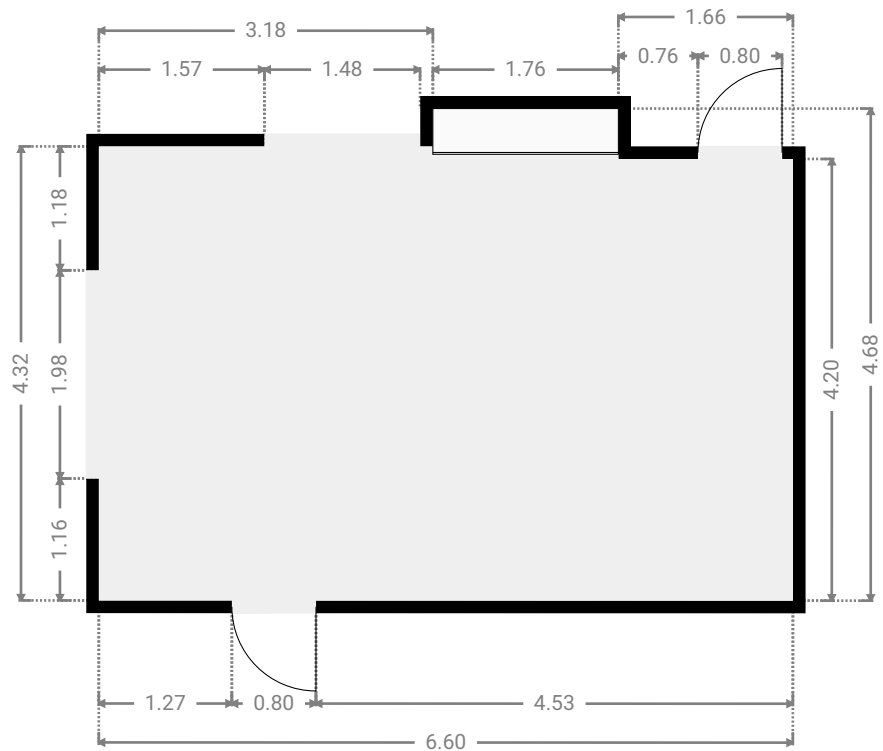
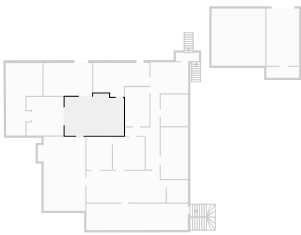

▼ Hall
1st Floor

WIDTH: 3.86 m • LENGTH: 4.69 m
AREA: 9.41 m² • PERIMETER: 17.09 m

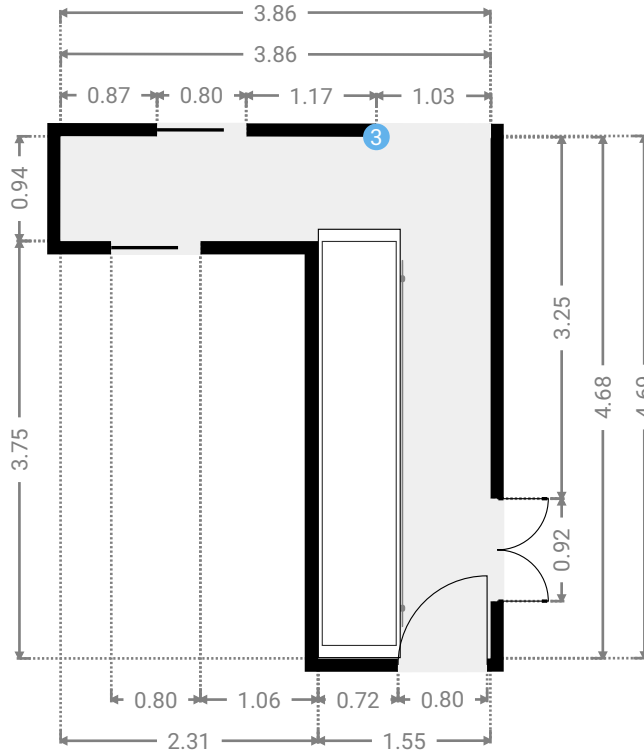
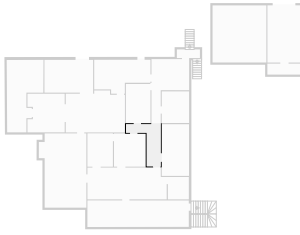

▼ Hall
1st Floor

WIDTH: 1.03 m • LENGTH: 3.70 m
AREA: 3.81 m² • PERIMETER: 9.46 m

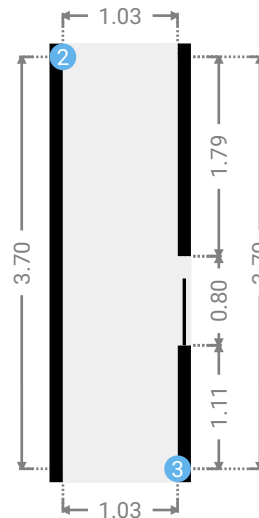

▼ Hall/1st Floor

2 OPENING

Height
0.00 m



3 OPENING

Height
0.00 m



▼ Kitchen
1st Floor

WIDTH: 6.27 m • LENGTH: 3.78 m
AREA: 19.31 m² • PERIMETER: 20.10 m

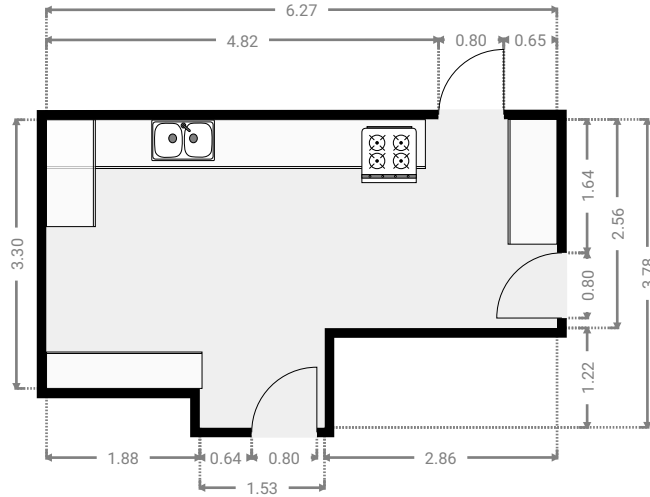

▼ Living Room
1st Floor

WIDTH: 8.84 m • LENGTH: 3.55 m
AREA: 30.66 m² • PERIMETER: 24.77 m

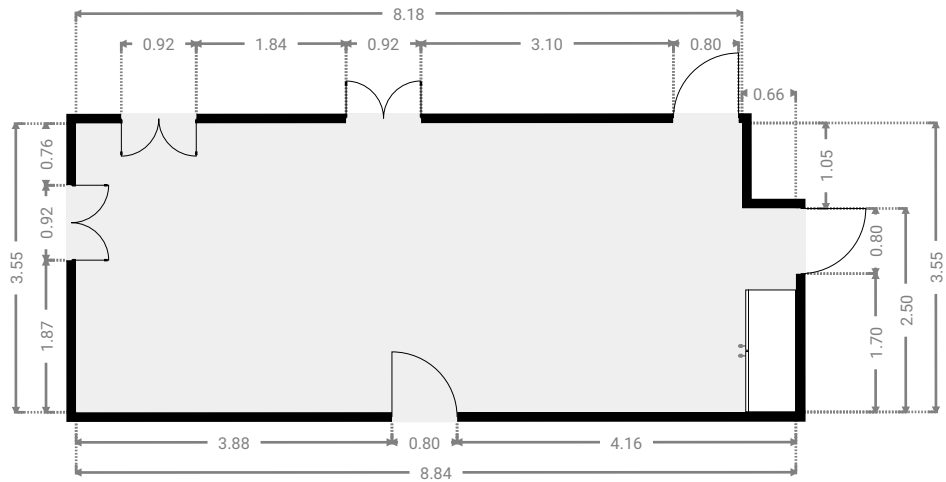
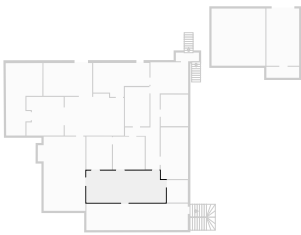

▼ **Living Room**
1st Floor

WIDTH: 4.15 m • LENGTH: 4.31 m
AREA: 17.03 m² • PERIMETER: 18.11 m

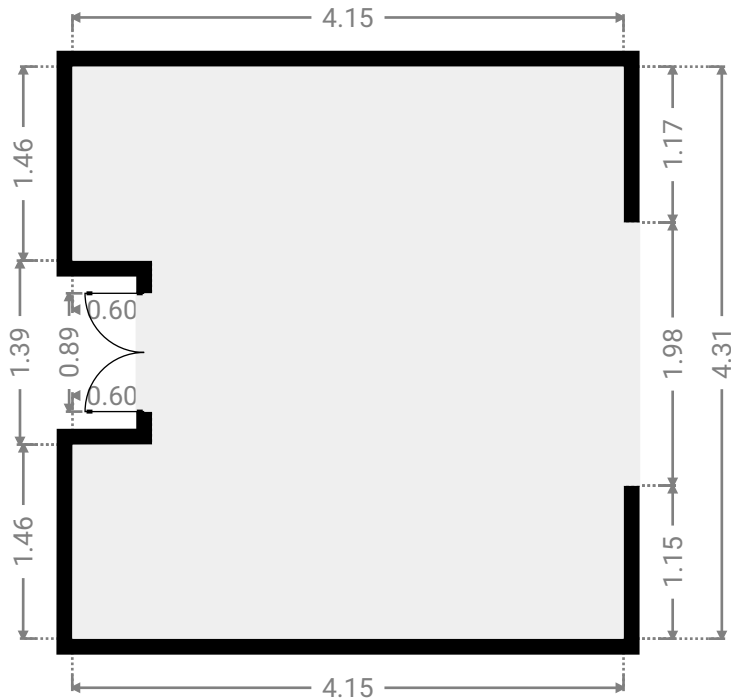
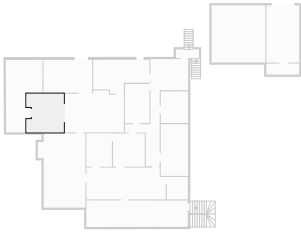

▼ **Living Room**
1st Floor

WIDTH: 5.43 m • LENGTH: 3.65 m
AREA: 19.82 m² • PERIMETER: 18.16 m

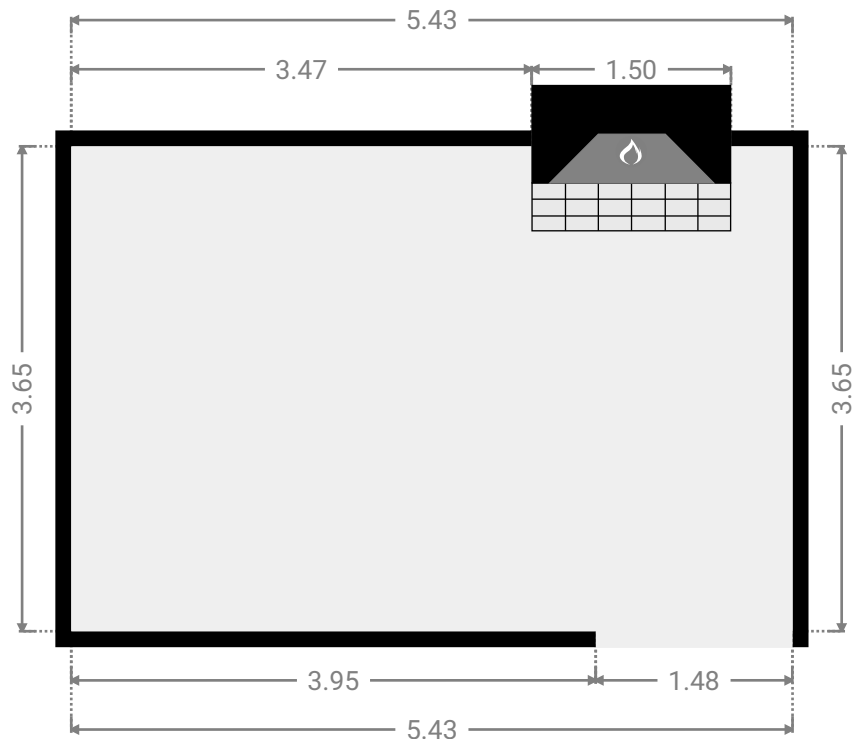
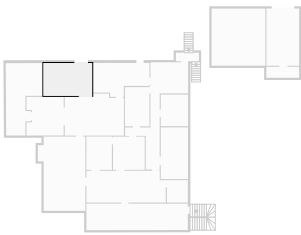

FLOORS: 2

▼ Living Room
1st Floor

WIDTH: 3.65 m • LENGTH: 6.38 m
AREA: 23.29 m² • PERIMETER: 20.06 m

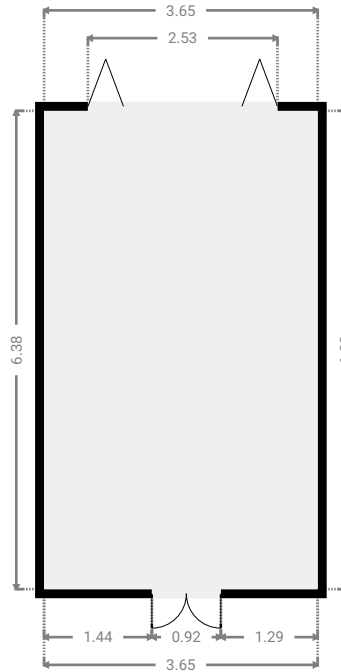
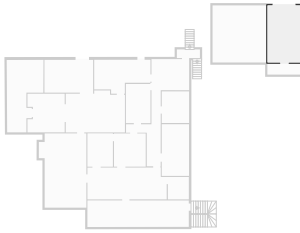

▼ Other
1st Floor

WIDTH: 11.31 m • LENGTH: 2.97 m
AREA: 33.39 m² • PERIMETER: 28.52 m

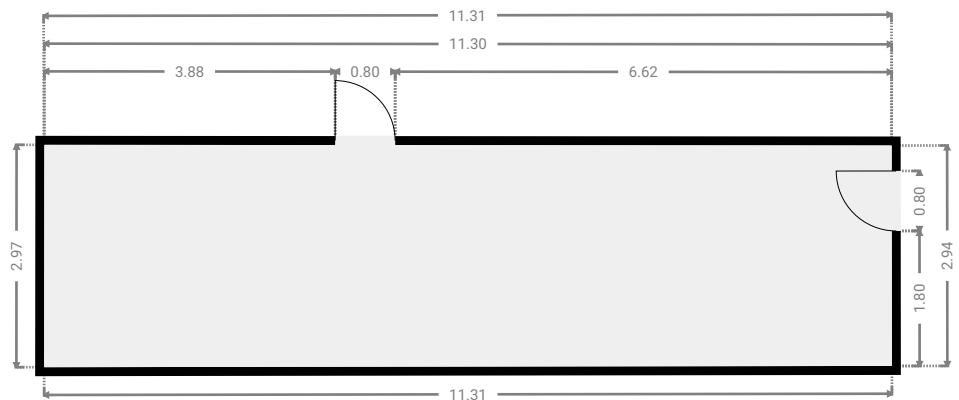
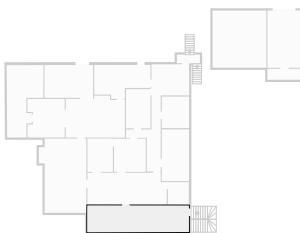

FLOORS: 2

▼ Other
1st Floor

WIDTH: 2.57 m • LENGTH: 0.96 m
AREA: 2.47 m² • PERIMETER: 7.06 m

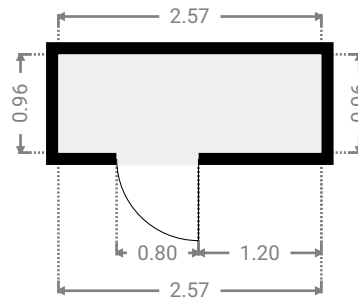
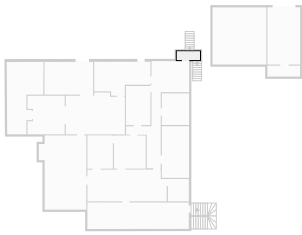

▼ Other
1st Floor

WIDTH: 6.00 m • LENGTH: 6.37 m
AREA: 38.19 m² • PERIMETER: 24.73 m

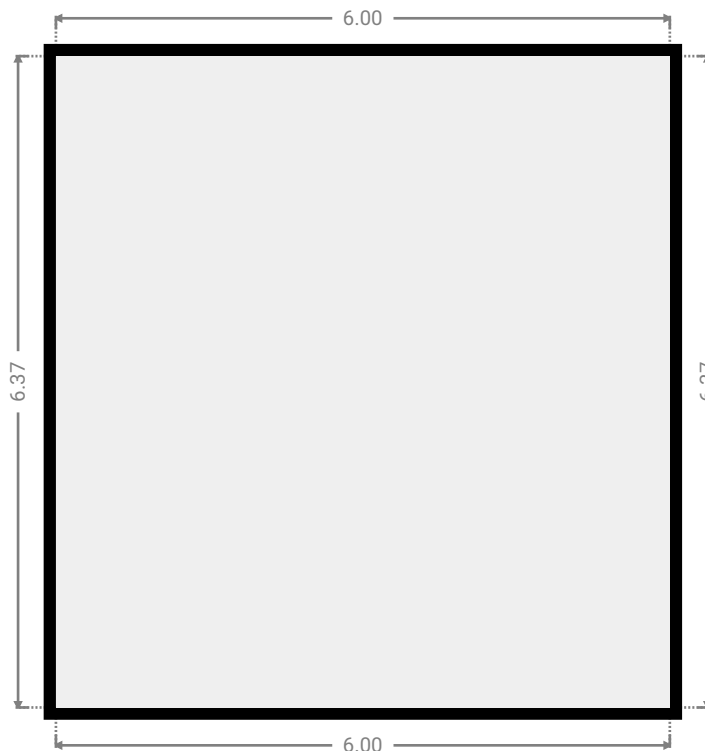
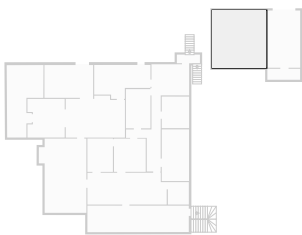

▼ Other
1st Floor

WIDTH: 3.65 m • LENGTH: 1.22 m
AREA: 4.46 m² • PERIMETER: 9.74 m

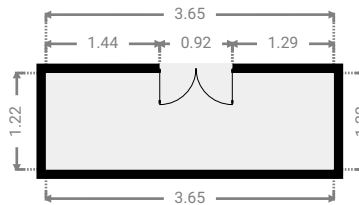
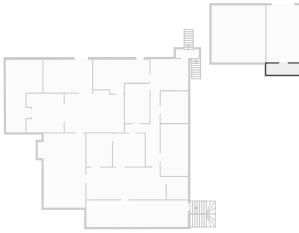

▼ Other
1st Floor

WIDTH: 4.10 m • LENGTH: 8.09 m
AREA: 25.13 m² • PERIMETER: 25.49 m

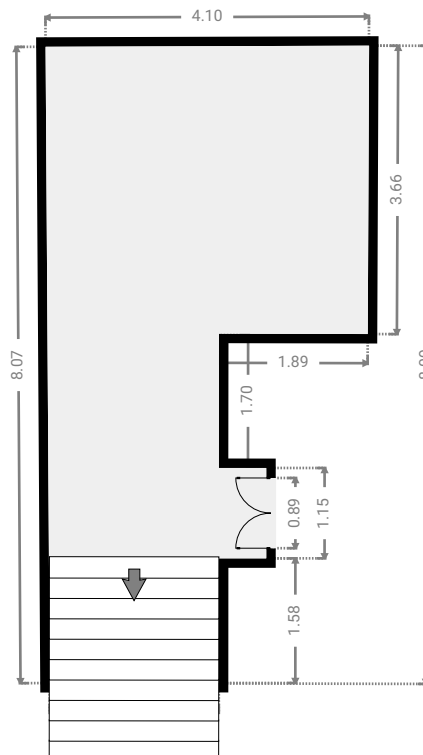
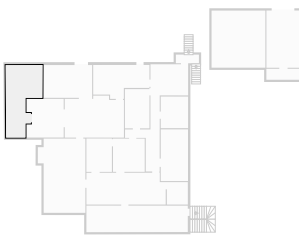

▼ **Primary Bedroom**
1st Floor

WIDTH: 5.30 m • LENGTH: 8.28 m
AREA: 39.67 m² • PERIMETER: 27.16 m

