

# 24-26 Ashgrove Crescent

SUBMITTED BY  
Janelle Casey

---

CREATED ON  
2021-10-21

Floors 1
-------------

---

FLOORS: 1

## ▼ Ground Floor

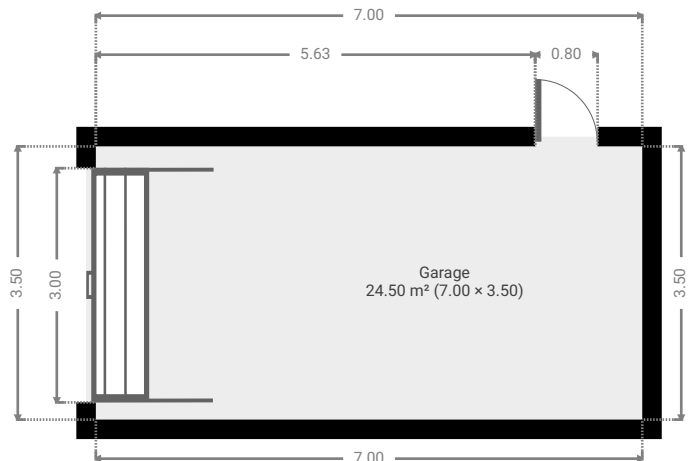

THIS FLOORPLAN IS PROVIDED WITHOUT WARRANTY OF ANY KIND. SENSOPIA DISCLAIMS ANY WARRANTY INCLUDING, WITHOUT LIMITATION, SATISFACTORY QUALITY OR ACCURACY OF DIMENSIONS.

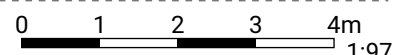

1:97

FLOORS: 1

▼ **Living Room**  
Ground Floor

WIDTH: 6.24 m • LENGTH: 4.41 m  
AREA: 26.39 m<sup>2</sup> • PERIMETER: 21.25 m

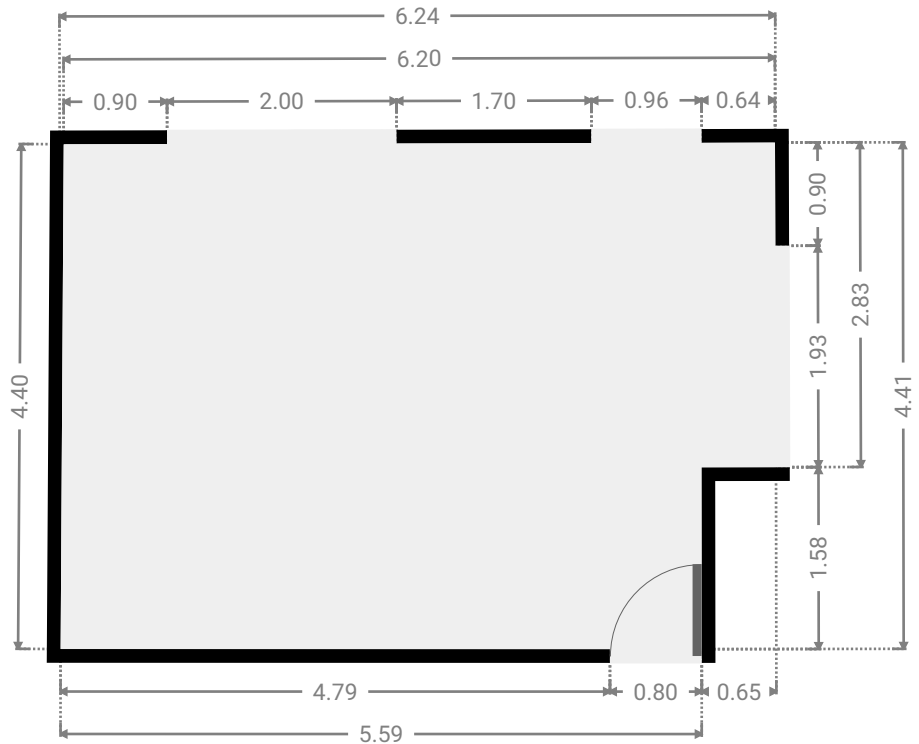
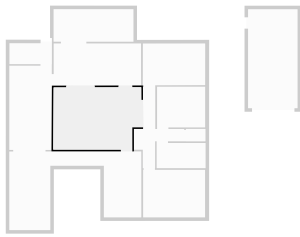

▼ **Kitchen**  
Ground Floor

WIDTH: 6.18 m • LENGTH: 2.97 m  
AREA: 18.37 m<sup>2</sup> • PERIMETER: 18.31 m

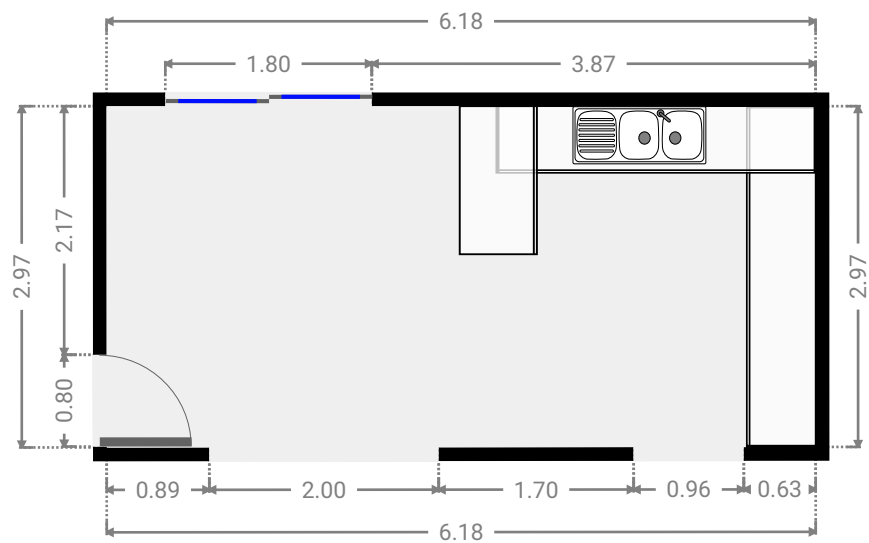
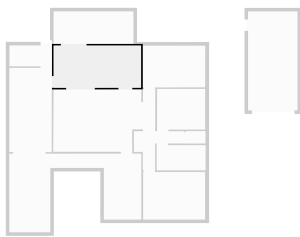

FLOORS: 1

## ▼ Laundry Room Ground Floor

WIDTH: 3.00 m • LENGTH: 1.48 m  
AREA: 4.44 m<sup>2</sup> • PERIMETER: 8.96 m

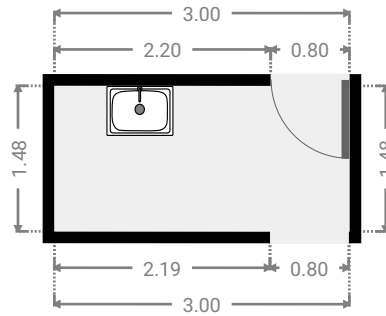
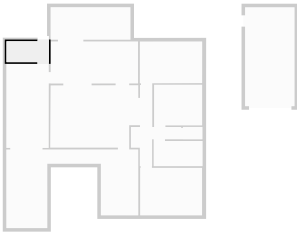

## ▼ Garage Ground Floor

WIDTH: 3.00 m • LENGTH: 5.96 m  
AREA: 17.88 m<sup>2</sup> • PERIMETER: 17.92 m

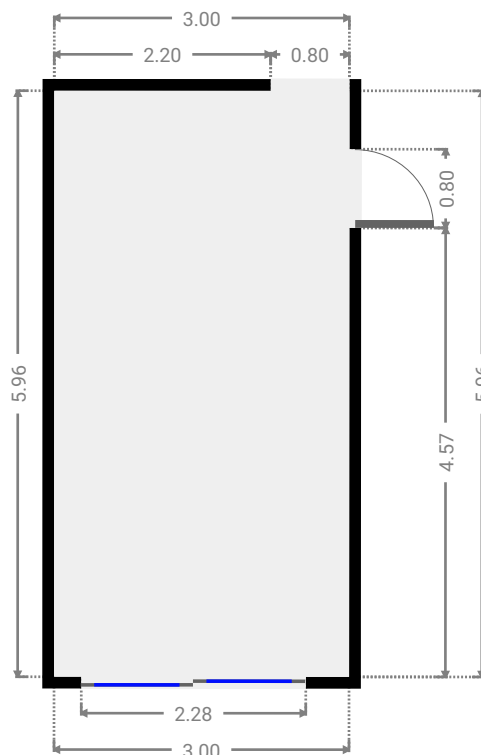
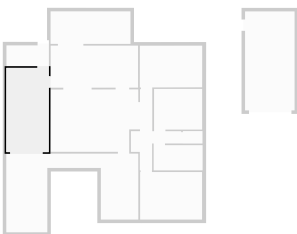

FLOORS: 1

▼ **Hall**  
Ground Floor

WIDTH: 3.56 m • LENGTH: 5.74 m  
AREA: 7.70 m<sup>2</sup> • PERIMETER: 18.60 m

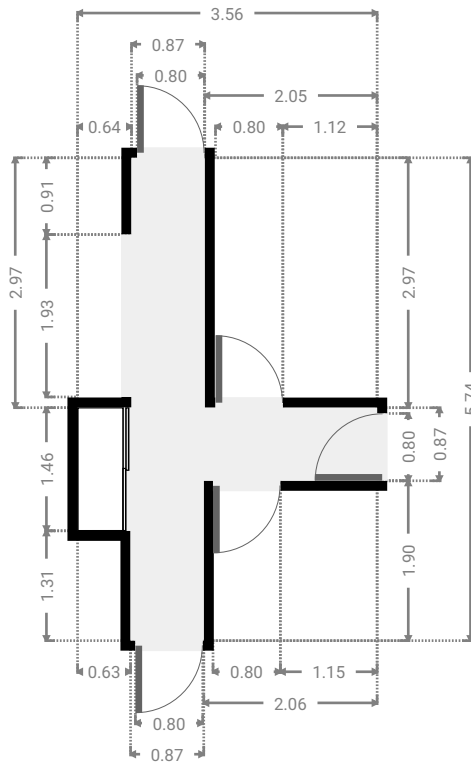
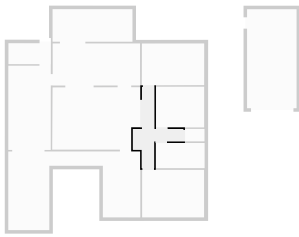

▼ **Master Bedroom**  
Ground Floor

WIDTH: 4.38 m • LENGTH: 3.36 m  
AREA: 14.72 m<sup>2</sup> • PERIMETER: 15.48 m

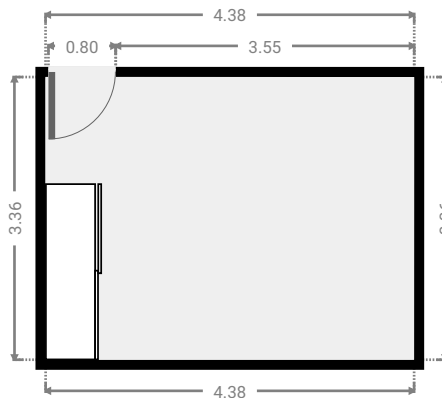
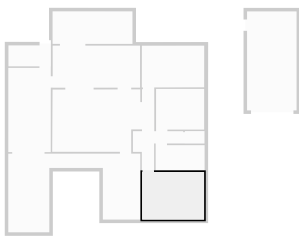

FLOORS: 1

▼ **Bathroom**  
Ground Floor

WIDTH: 3.46 m • LENGTH: 1.78 m  
AREA: 6.16 m<sup>2</sup> • PERIMETER: 10.48 m

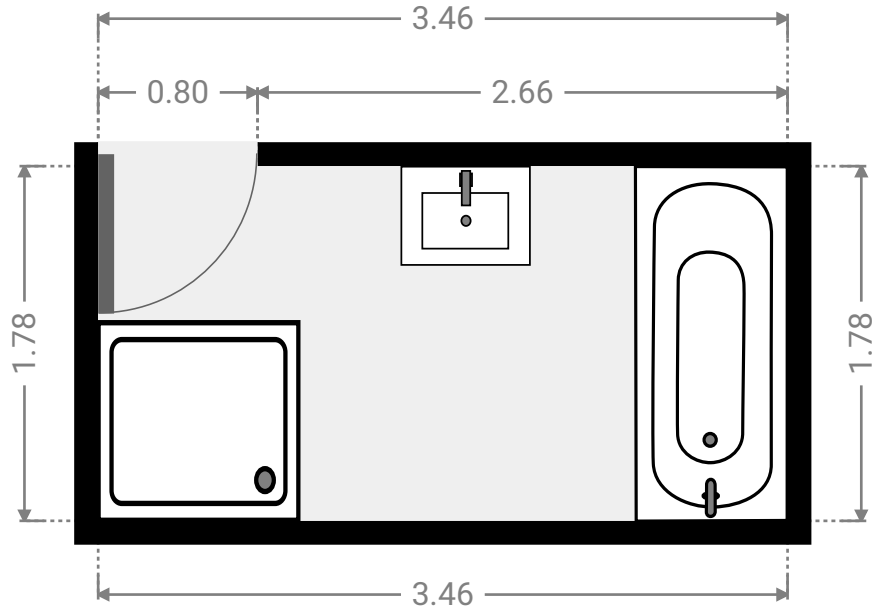
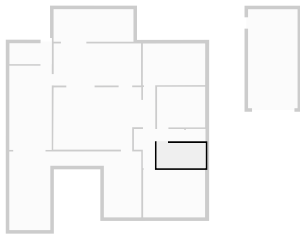

▼ **Toilet**  
Ground Floor

WIDTH: 1.39 m • LENGTH: 0.88 m  
AREA: 1.22 m<sup>2</sup> • PERIMETER: 4.54 m

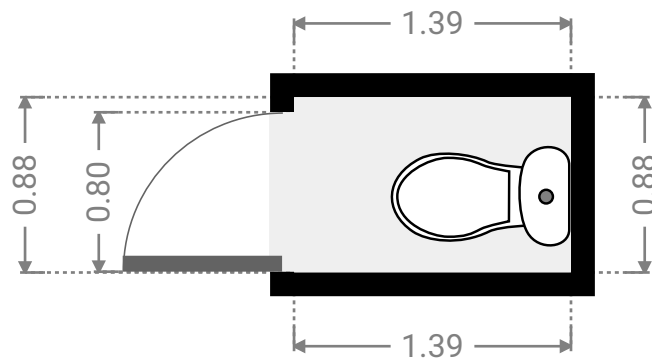
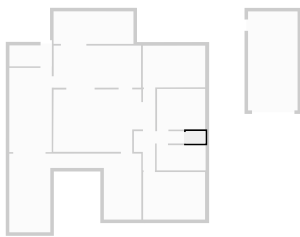

FLOORS: 1

▼ **Bedroom**  
Ground Floor

WIDTH: 3.40 m • LENGTH: 2.88 m  
AREA: 9.79 m<sup>2</sup> • PERIMETER: 12.56 m

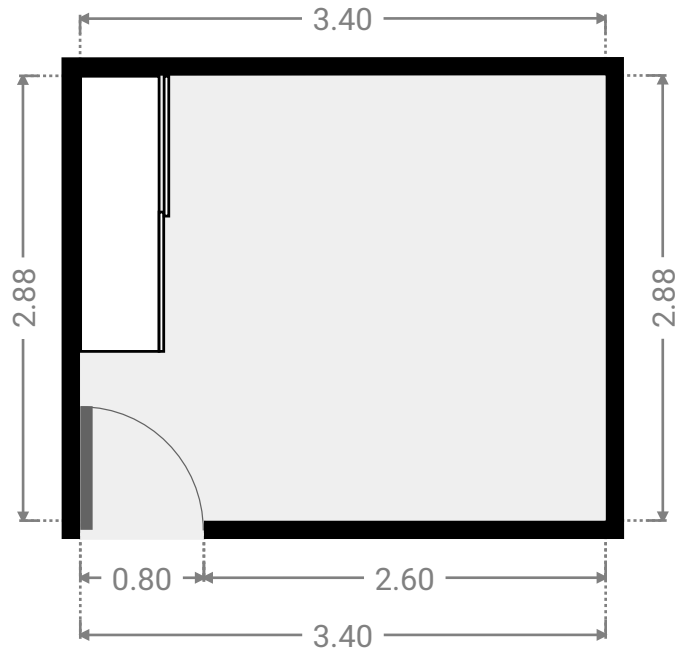
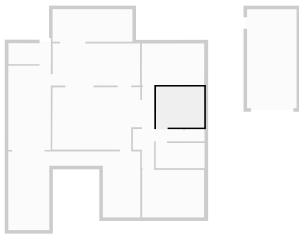

▼ **Bedroom**  
Ground Floor

WIDTH: 4.42 m • LENGTH: 2.96 m  
AREA: 13.01 m<sup>2</sup> • PERIMETER: 14.72 m

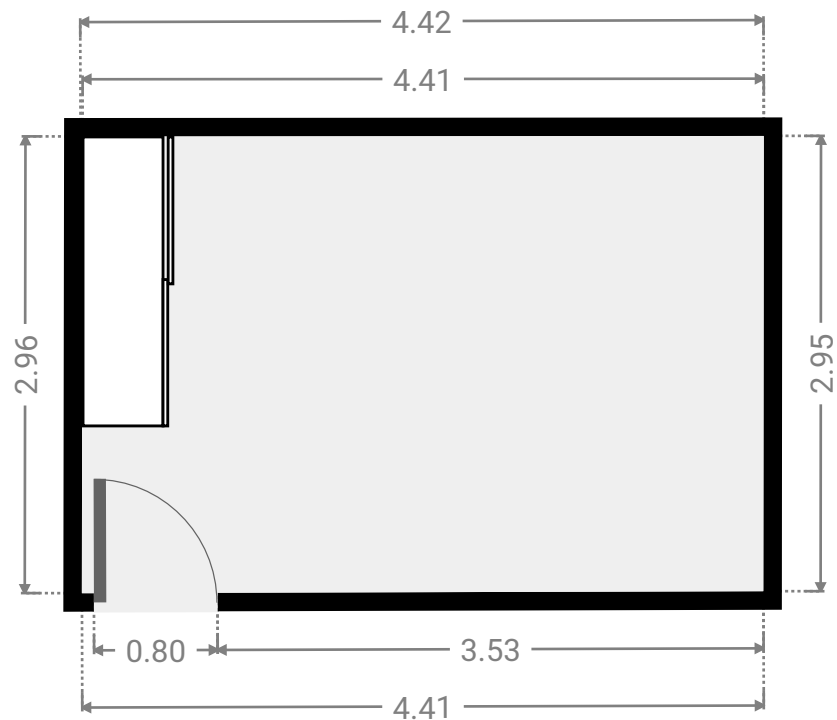
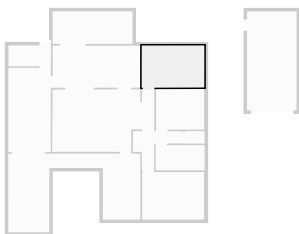

FLOORS: 1

▼ **Other**  
Ground Floor

WIDTH: 5.65 m • LENGTH: 2.30 m  
AREA: 13.00 m<sup>2</sup> • PERIMETER: 15.90 m

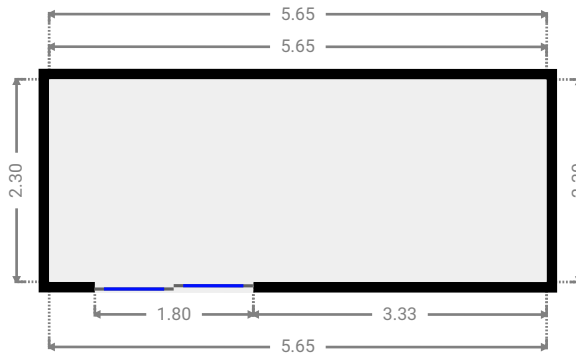
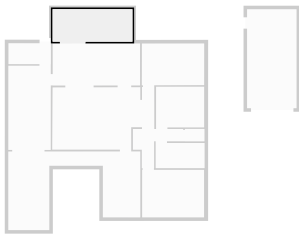

▼ **Carport/Verandah**  
Ground Floor

WIDTH: 9.34 m • LENGTH: 5.57 m  
AREA: 32.30 m<sup>2</sup> • PERIMETER: 37.10 m

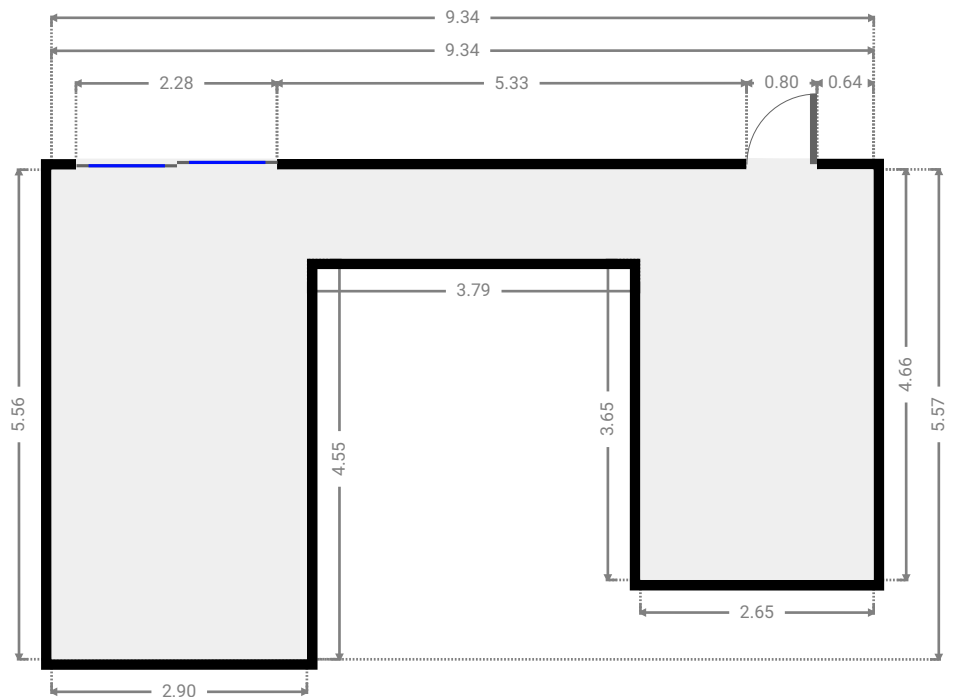
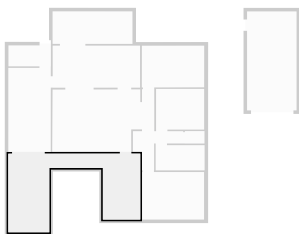



FLOORS: 1

## ▼ Garage Ground Floor

WIDTH: 3.50 m • LENGTH: 7.00 m  
AREA: 24.50 m<sup>2</sup> • PERIMETER: 21.00 m

