

24 Geoff Wilson Drive

SUBMITTED BY

Ray White Rockhampton Casey
stockers@cqoz.com

CREATED ON

2022-12-14

Floors

1

▼ Ground Floor

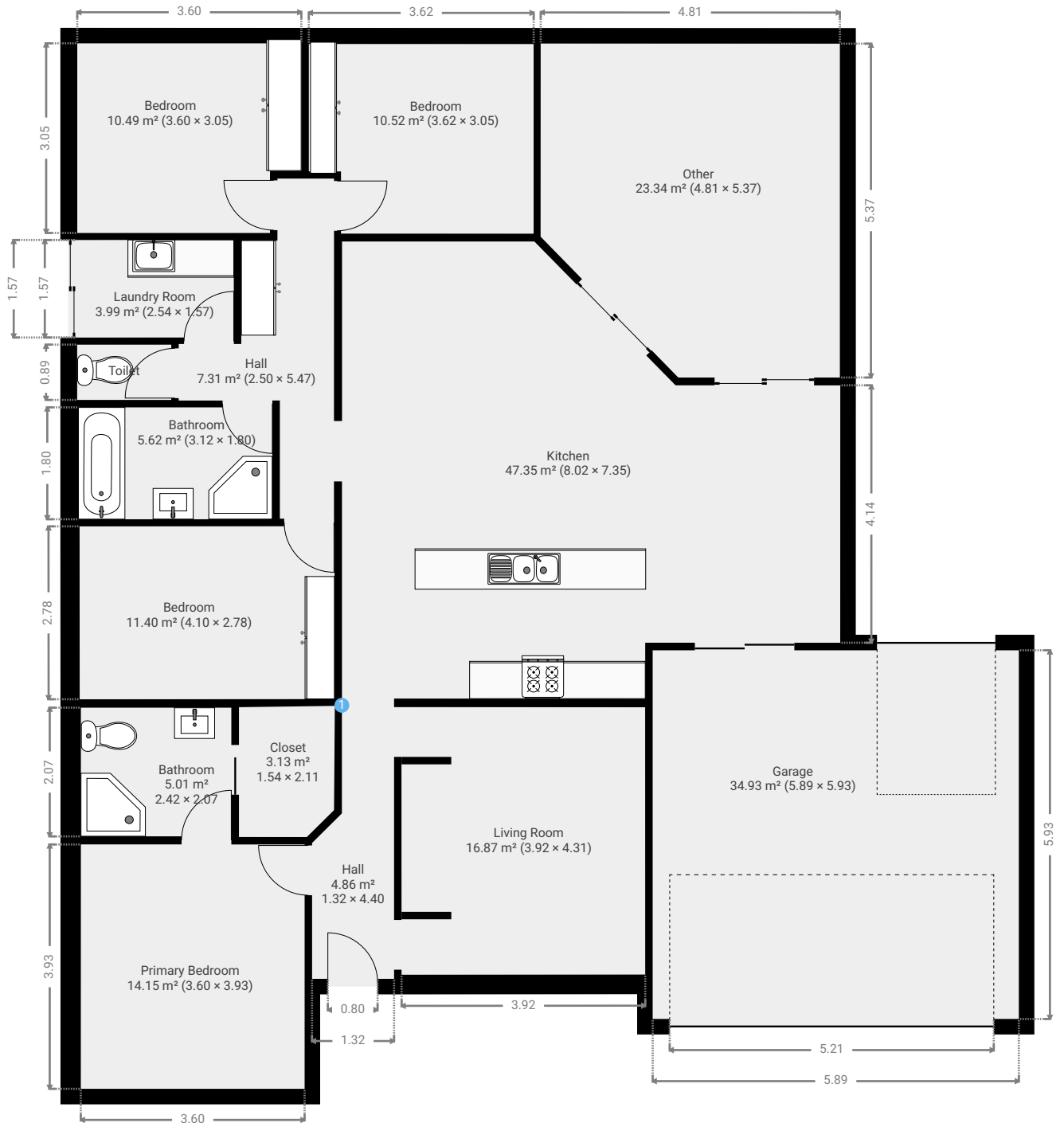

FLOORS: 1

▼ **Bathroom**
Ground Floor

WIDTH: 2.42 m • LENGTH: 2.07 m
AREA: 5.01 m² • PERIMETER: 8.98 m

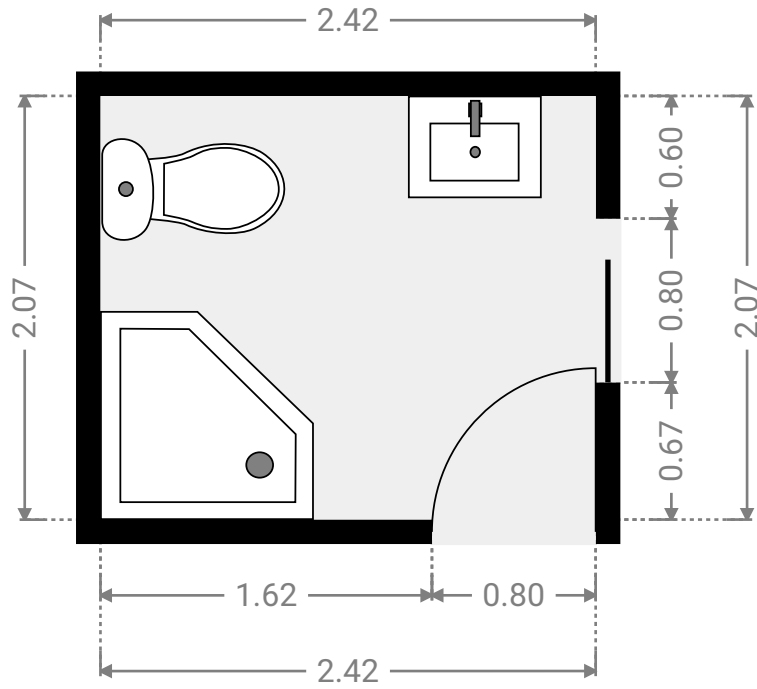

▼ **Closet**
Ground Floor

WIDTH: 1.54 m • LENGTH: 2.11 m
AREA: 3.13 m² • PERIMETER: 7.02 m

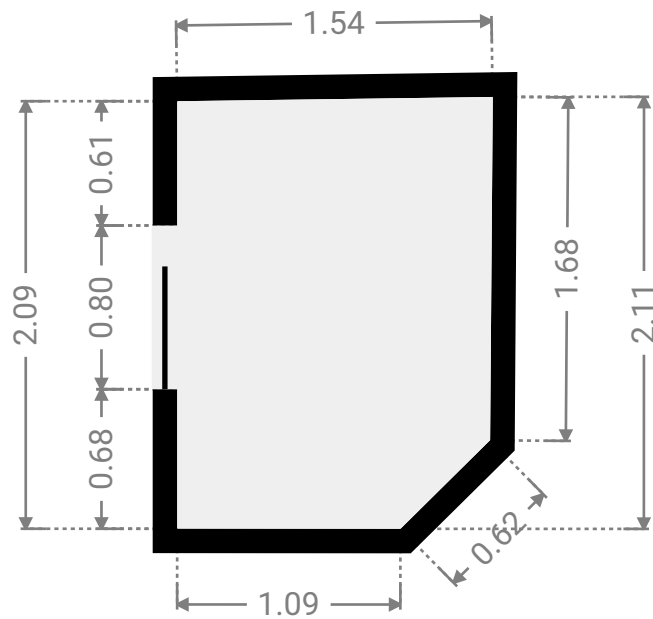
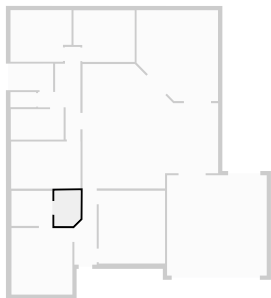

FLOORS: 1

▼ **Bathroom**
Ground Floor

WIDTH: 3.12 m • LENGTH: 1.80 m
AREA: 5.62 m² • PERIMETER: 9.84 m

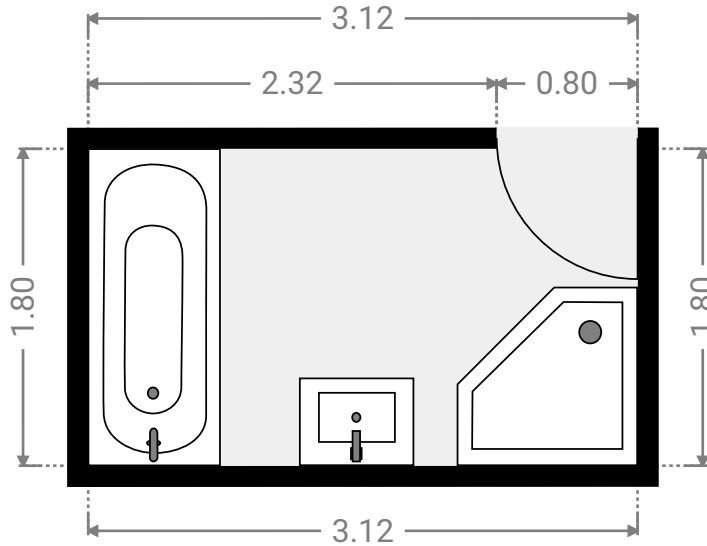
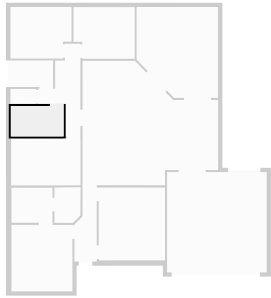

▼ **Bedroom**
Ground Floor

WIDTH: 4.10 m • LENGTH: 2.78 m
AREA: 11.40 m² • PERIMETER: 13.76 m

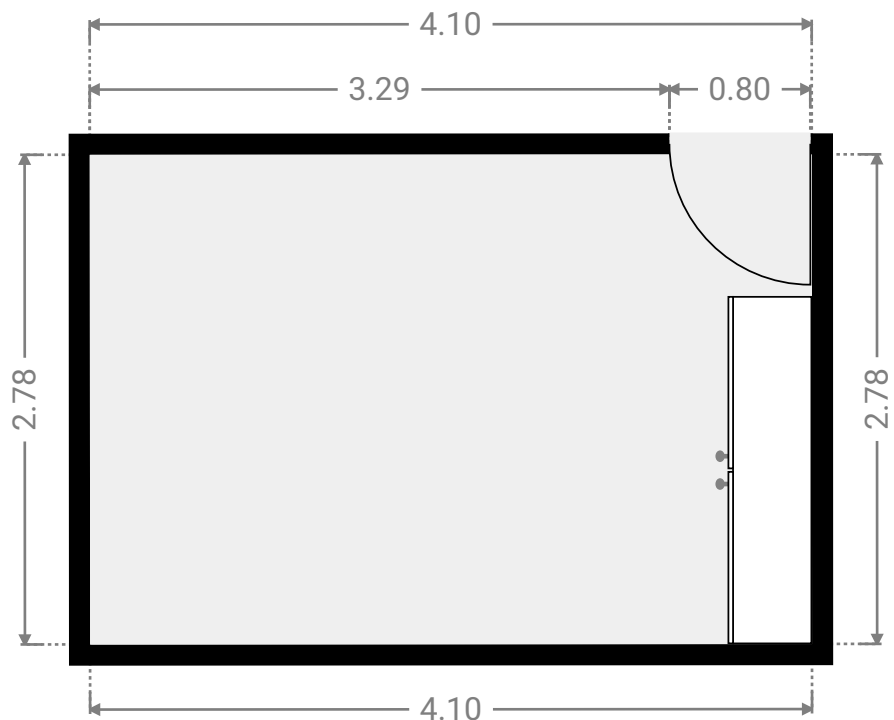
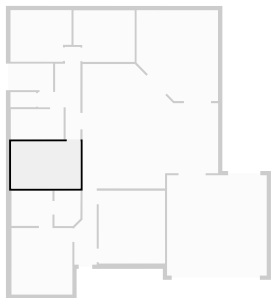

FLOORS: 1

▼ **Bedroom**
Ground Floor

WIDTH: 3.60 m • LENGTH: 3.05 m
AREA: 10.49 m² • PERIMETER: 13.31 m

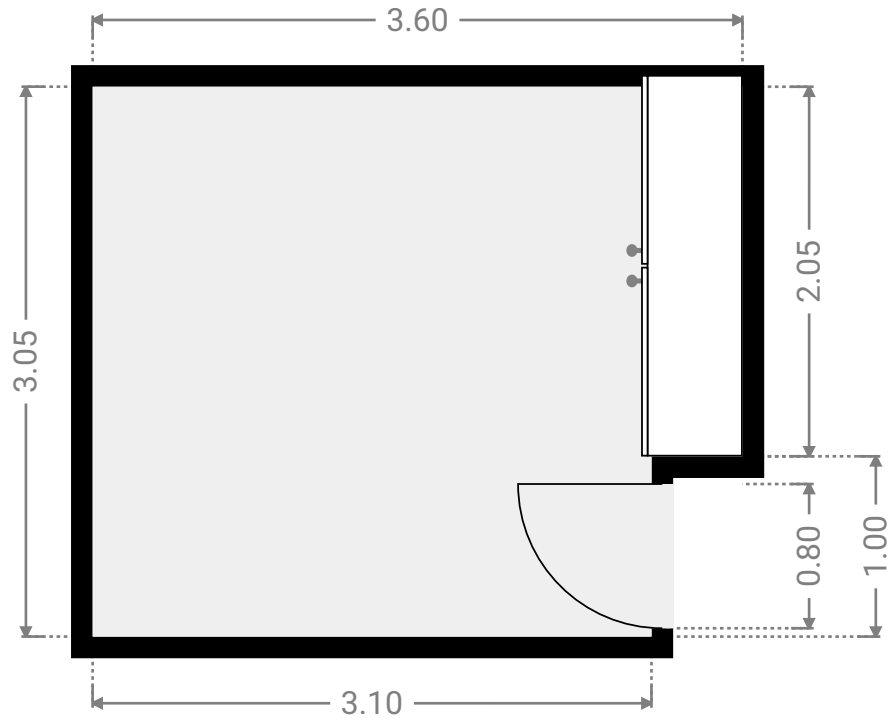

▼ **Bedroom**
Ground Floor

WIDTH: 3.62 m • LENGTH: 3.05 m
AREA: 10.52 m² • PERIMETER: 13.33 m

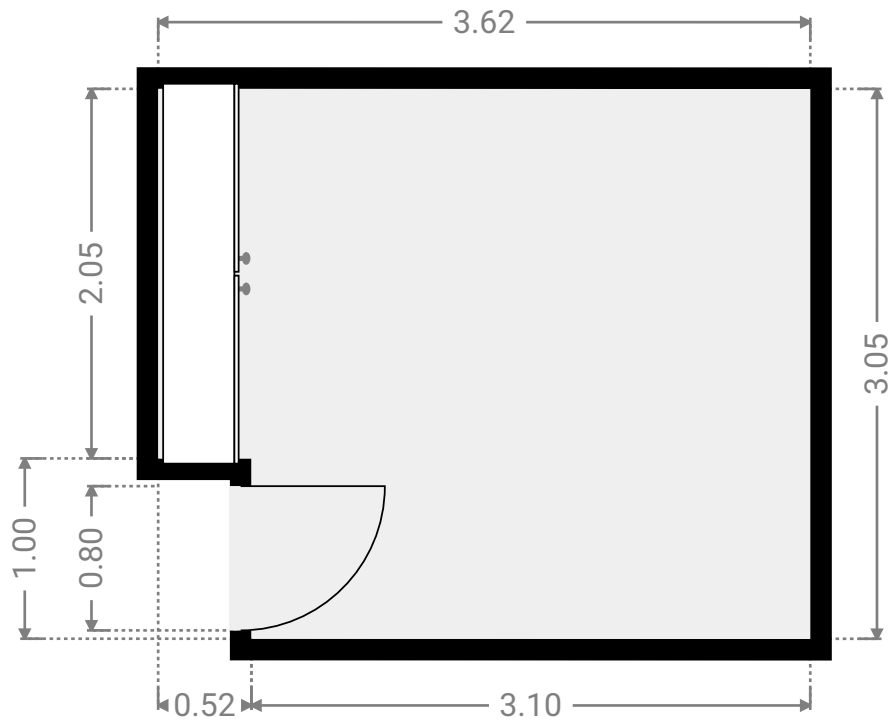
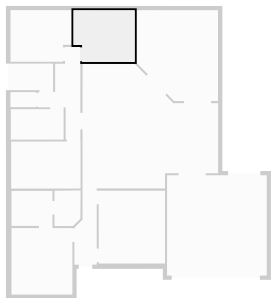

FLOORS: 1

▼ **Garage**
Ground Floor

WIDTH: 5.89 m • LENGTH: 5.93 m
AREA: 34.93 m² • PERIMETER: 23.64 m

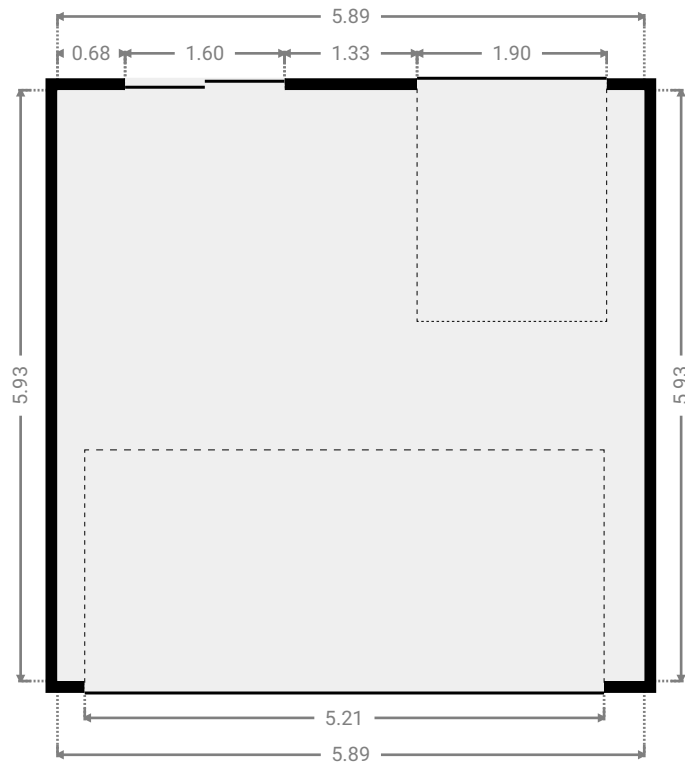
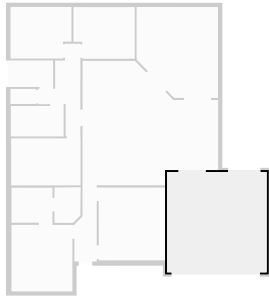

▼ **Hall**
Ground Floor

WIDTH: 1.32 m • LENGTH: 4.40 m
AREA: 4.86 m² • PERIMETER: 11.16 m

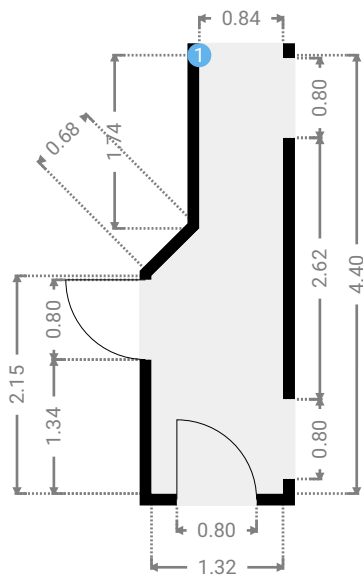
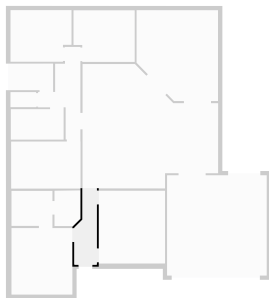

▼ Hall/Ground Floor

1 OPENING

Height
0.00 m



FLOORS: 1

▼ **Hall**
Ground Floor

WIDTH: 2.50 m • LENGTH: 5.47 m
AREA: 7.31 m² • PERIMETER: 15.94 m

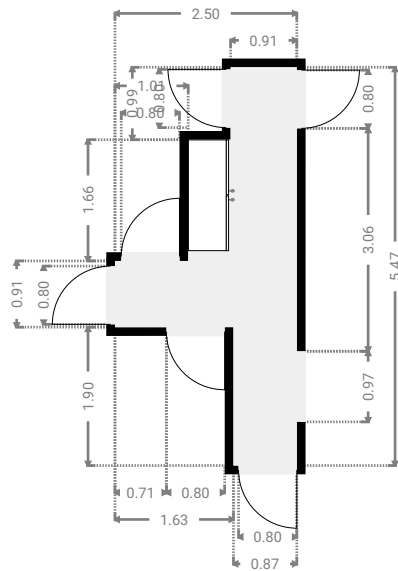

▼ **Kitchen**
Ground Floor

WIDTH: 8.02 m • LENGTH: 7.35 m
AREA: 47.35 m² • PERIMETER: 29.39 m

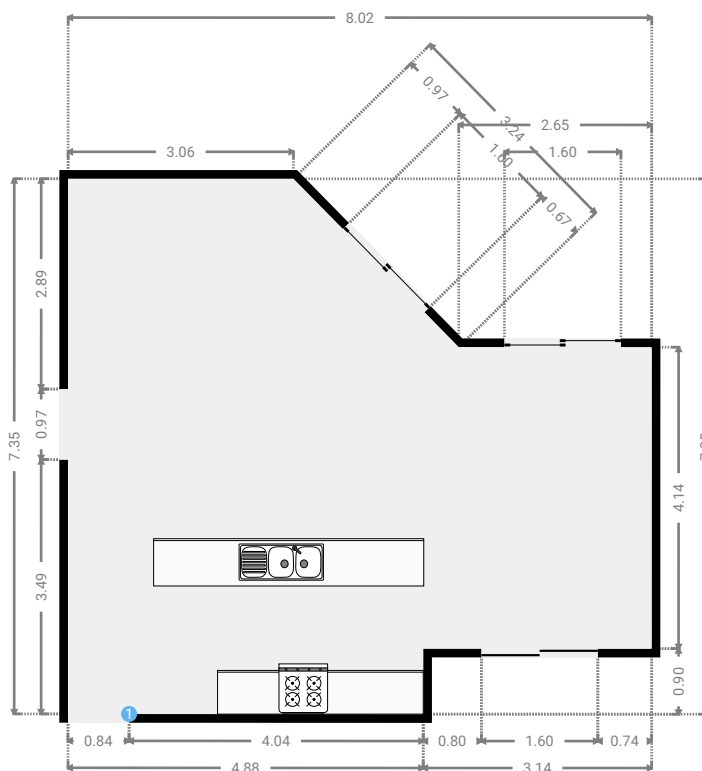
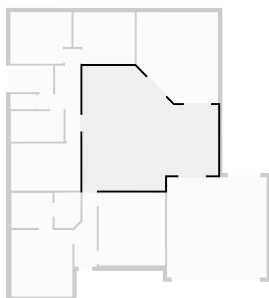

FLOORS: 1

▼ **Laundry Room**
Ground Floor

WIDTH: 2.54 m • LENGTH: 1.57 m
AREA: 3.99 m² • PERIMETER: 8.22 m

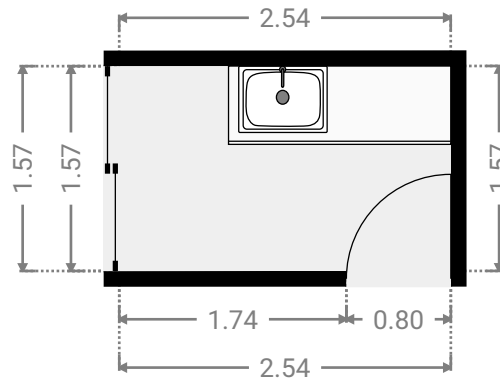

▼ **Living Room**
Ground Floor

WIDTH: 3.92 m • LENGTH: 4.31 m
AREA: 16.87 m² • PERIMETER: 16.45 m

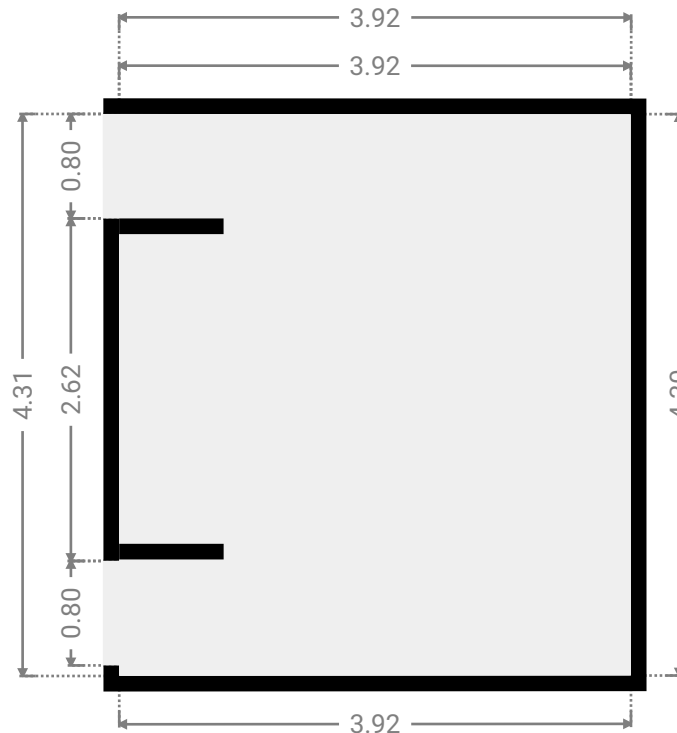
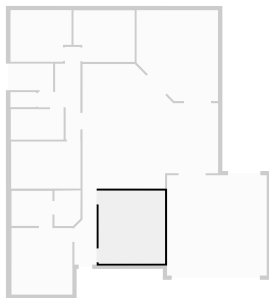

FLOORS: 1

▼ **Other**
Ground Floor

WIDTH: 4.81 m • LENGTH: 5.37 m
AREA: 23.34 m² • PERIMETER: 19.06 m

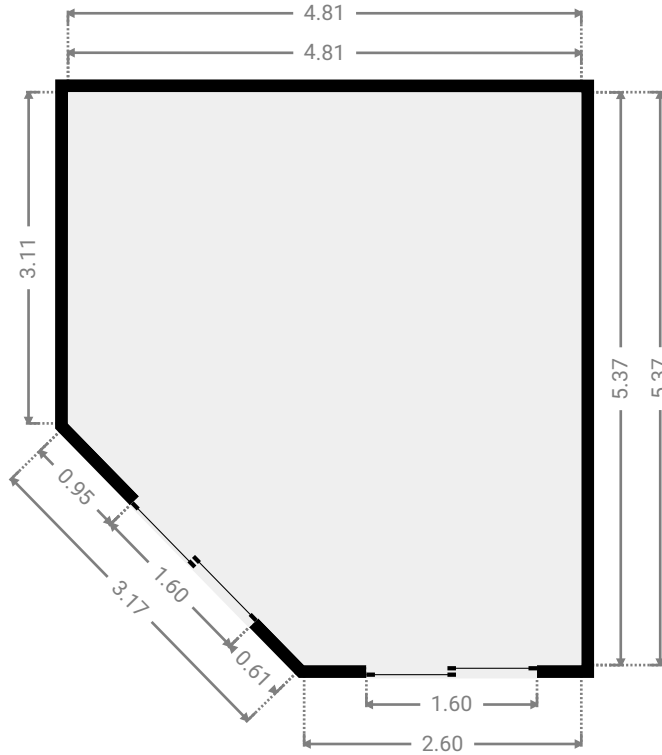
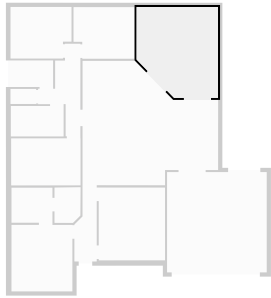

▼ **Primary Bedroom**
Ground Floor

WIDTH: 3.60 m • LENGTH: 3.93 m
AREA: 14.15 m² • PERIMETER: 15.06 m

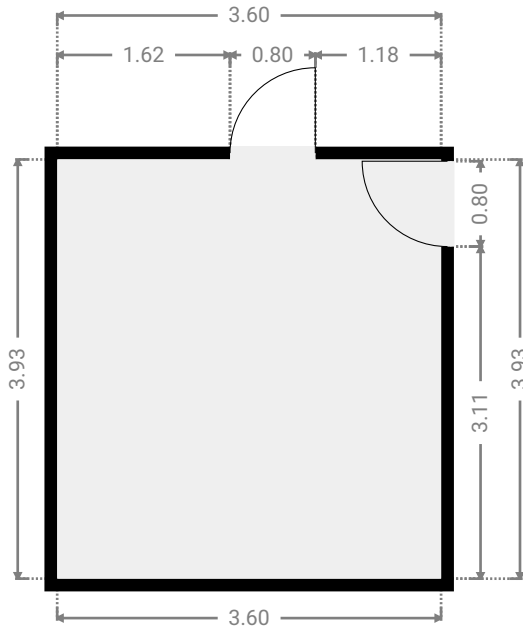

FLOORS: 1

▼ Toilet
Ground Floor

WIDTH: 1.51 m • LENGTH: 0.89 m
AREA: 1.35 m² • PERIMETER: 4.81 m

