

24 Buckle Street

Created on
2021-03-09

Floors
1



▼ Ground Floor

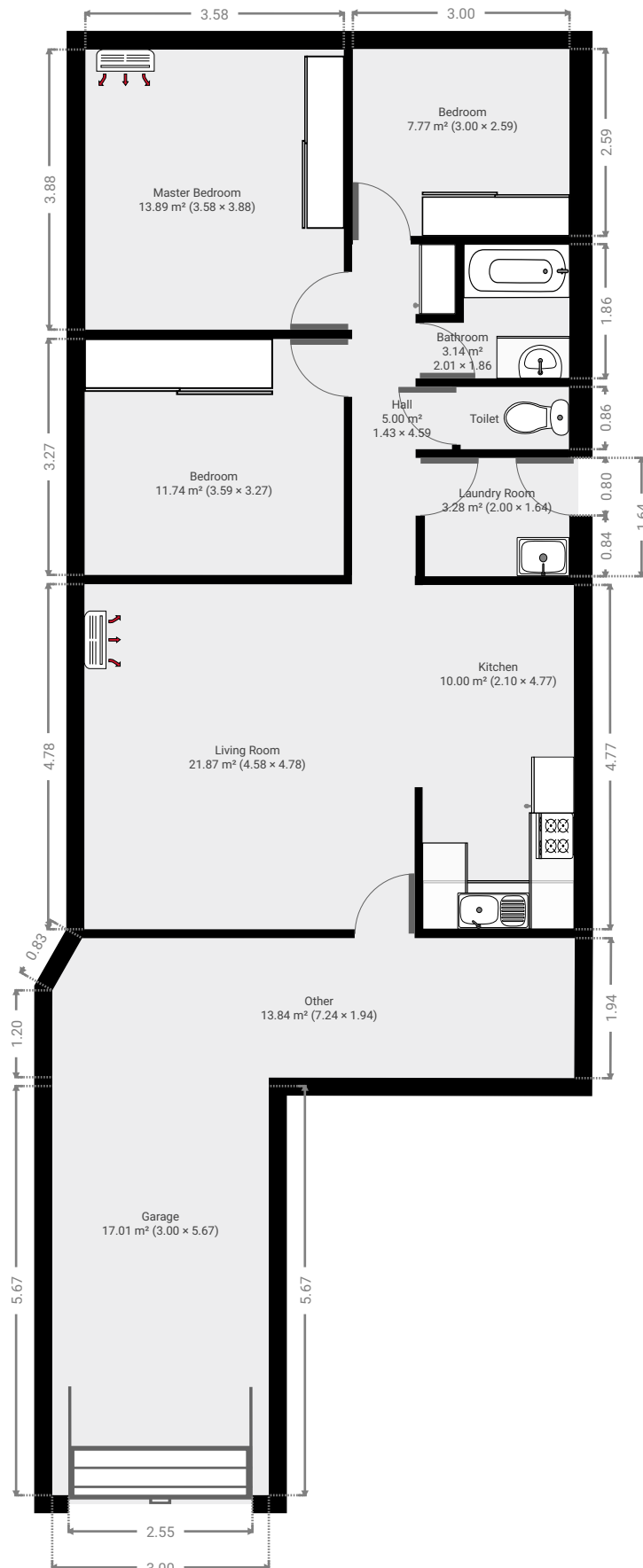

▼ **Garage**
Ground Floor

WIDTH: 3.00 m • LENGTH: 5.67 m
AREA: 17.01 m² • PERIMETER: 17.34 m

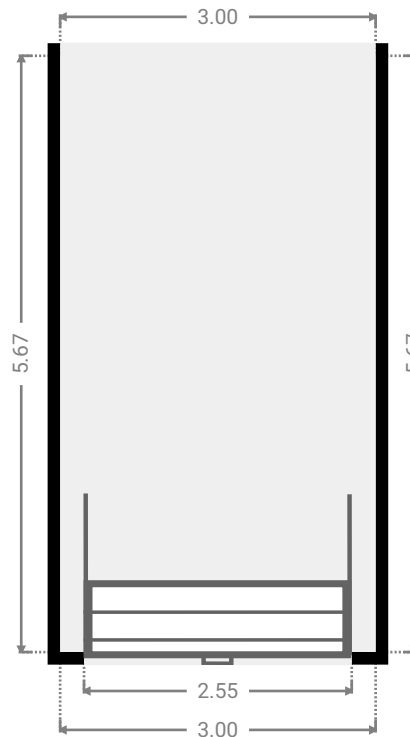

▼ **Other**
Ground Floor

WIDTH: 7.24 m • LENGTH: 1.94 m
AREA: 13.84 m² • PERIMETER: 18.03 m

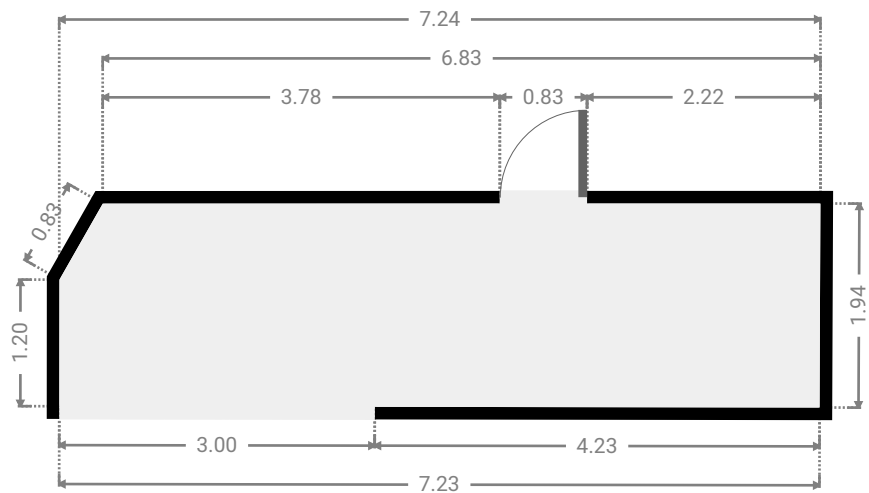
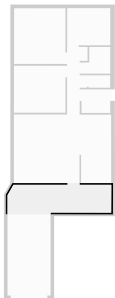

▼ Living Room
Ground Floor

WIDTH: 4.58 m • LENGTH: 4.78 m
AREA: 21.87 m² • PERIMETER: 18.71 m

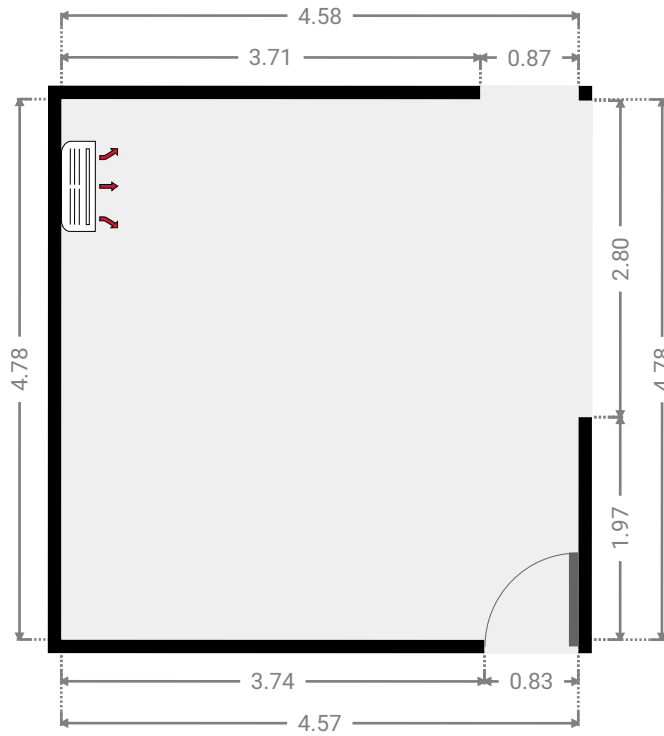
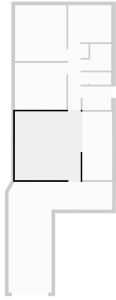

▼ Kitchen
Ground Floor

WIDTH: 2.10 m • LENGTH: 4.77 m
AREA: 10.00 m² • PERIMETER: 13.73 m

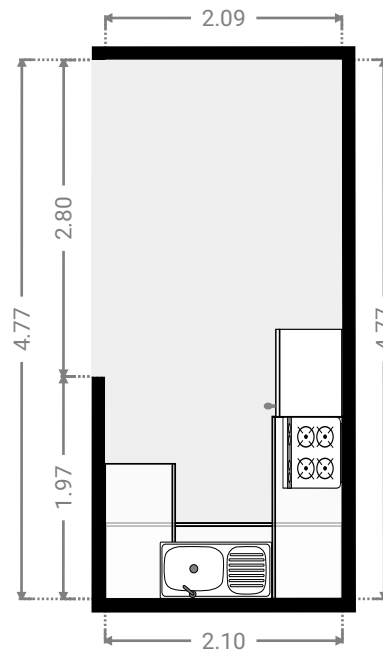
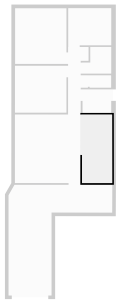

▼ **Hall**
Ground Floor

WIDTH: 1.43 m • LENGTH: 4.59 m
AREA: 5.00 m² • PERIMETER: 13.05 m

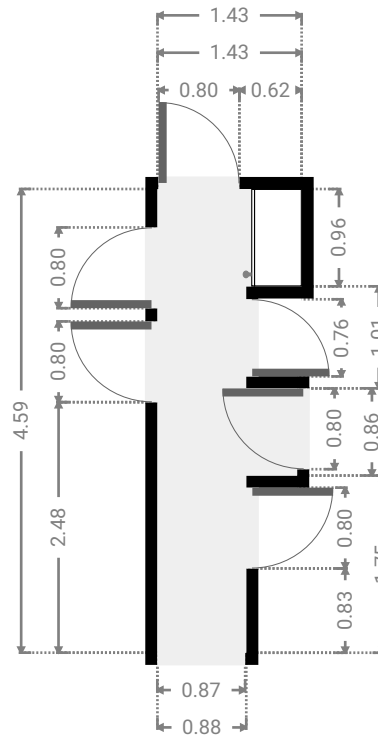
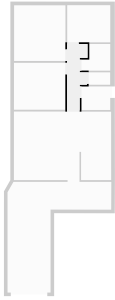

▼ **Laundry Room**
Ground Floor

WIDTH: 2.00 m • LENGTH: 1.64 m
AREA: 3.28 m² • PERIMETER: 7.28 m

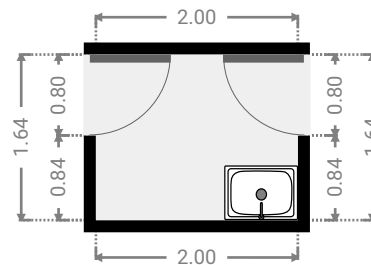
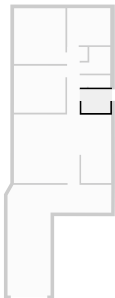

▼ **Bedroom**
Ground Floor

WIDTH: 3.59 m • LENGTH: 3.27 m
AREA: 11.74 m² • PERIMETER: 13.72 m

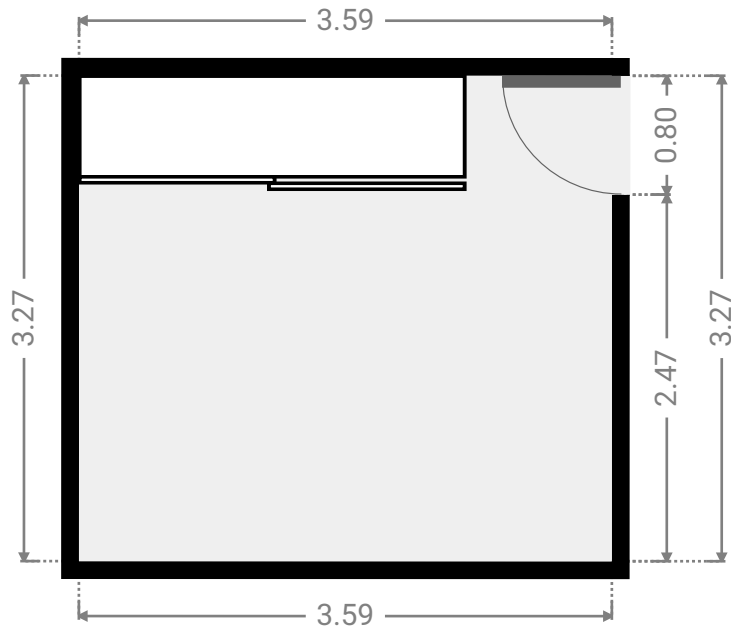
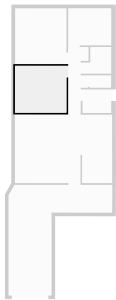

▼ **Master Bedroom**
Ground Floor

WIDTH: 3.58 m • LENGTH: 3.88 m
AREA: 13.89 m² • PERIMETER: 14.92 m

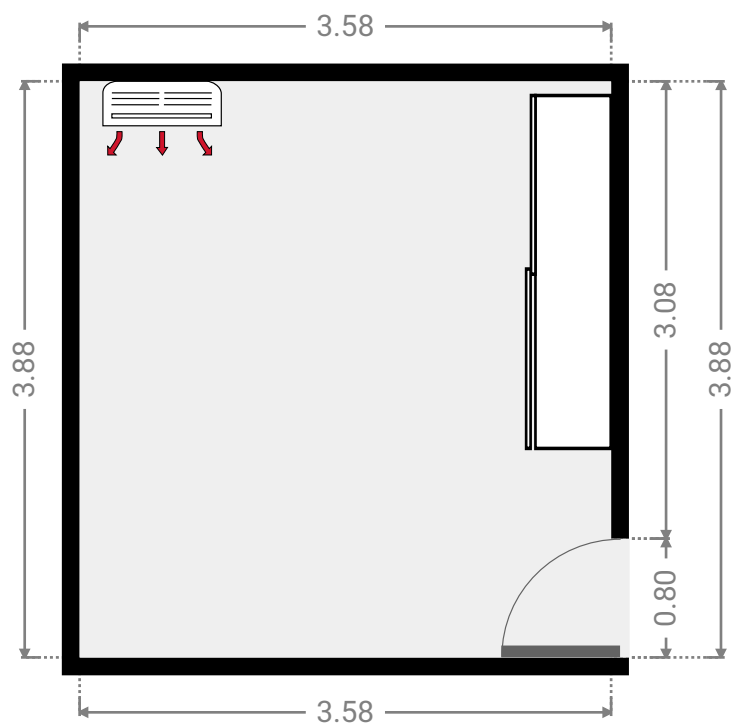

▼ **Bedroom**
Ground Floor

WIDTH: 3.00 m • LENGTH: 2.59 m
AREA: 7.77 m² • PERIMETER: 11.18 m

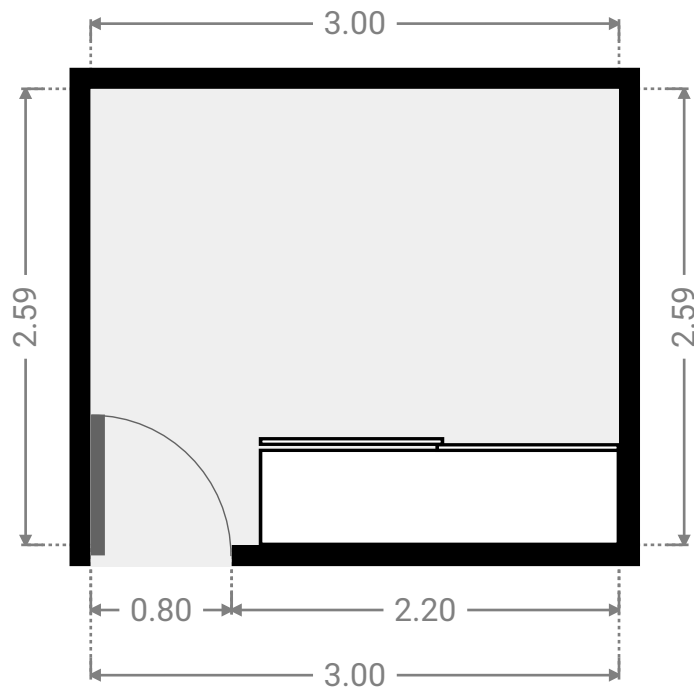
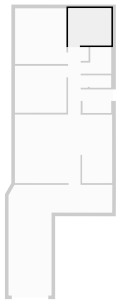

▼ **Bathroom**
Ground Floor

WIDTH: 2.01 m • LENGTH: 1.86 m
AREA: 3.14 m² • PERIMETER: 7.74 m

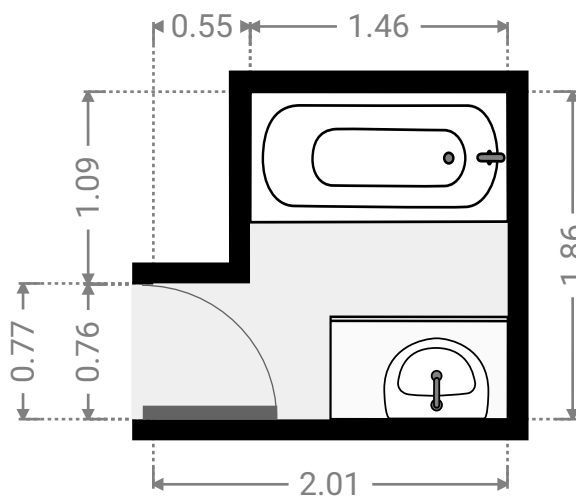

▼ Toilet
Ground Floor

WIDTH: 1.50 m • LENGTH: 0.86 m
AREA: 1.30 m² • PERIMETER: 4.73 m

