

239 Flowers Avenue

Created on
2021-05-24

Floors
2

▼ Ground Floor



▼ **Stairway**
Ground Floor

WIDTH: 2.96 m • LENGTH: 1.83 m
AREA: 5.42 m² • PERIMETER: 9.58 m

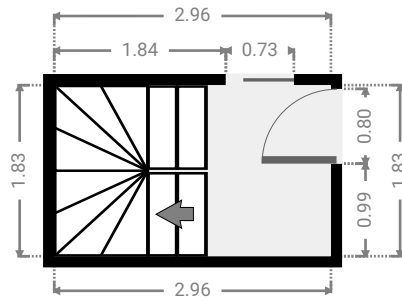

▼ **Living Room**
Ground Floor

WIDTH: 8.34 m • LENGTH: 3.47 m
AREA: 24.56 m² • PERIMETER: 25.03 m

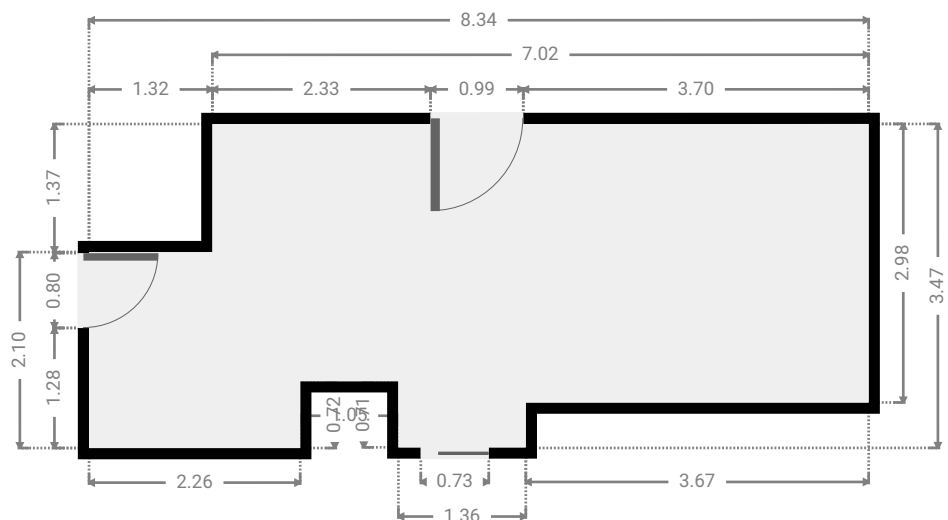
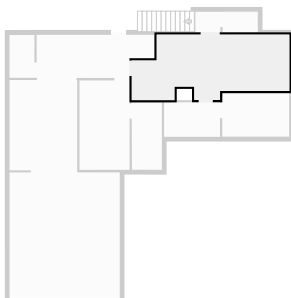

▼ Laundry Room
Ground Floor

WIDTH: 6.23 m • LENGTH: 2.28 m
AREA: 12.84 m² • PERIMETER: 17.02 m

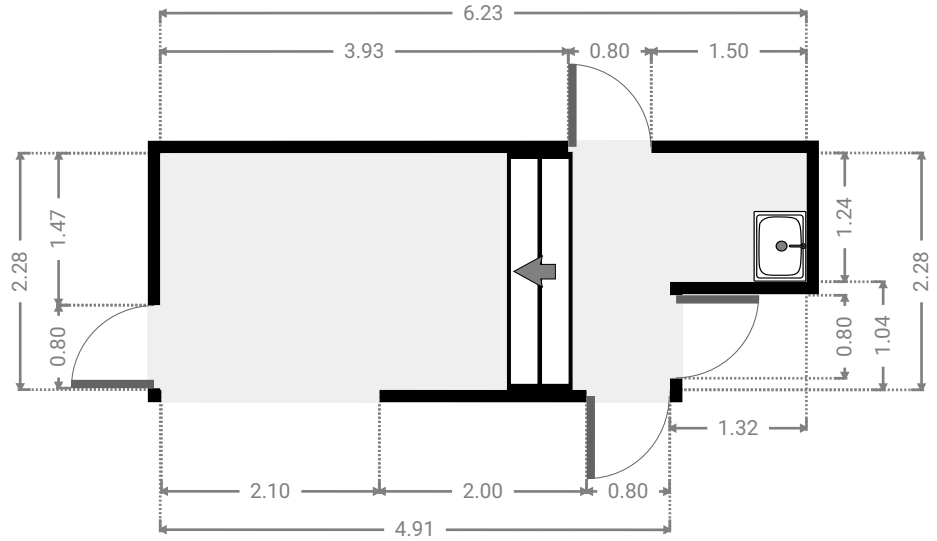
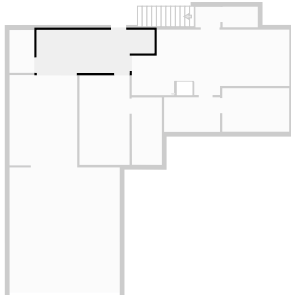

▼ Garage
Ground Floor

WIDTH: 3.58 m • LENGTH: 4.78 m
AREA: 17.11 m² • PERIMETER: 16.72 m

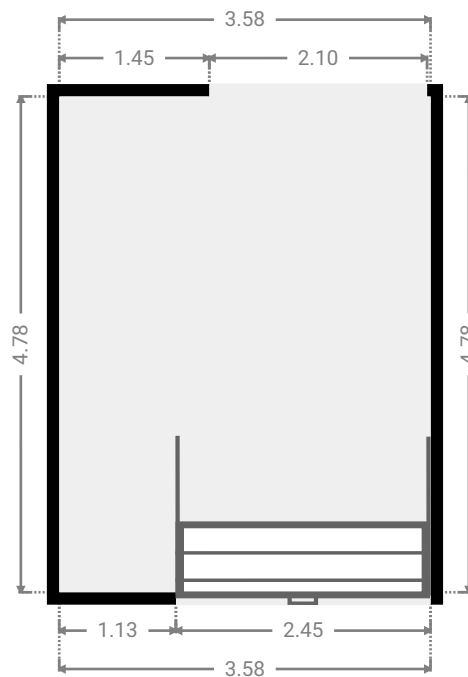
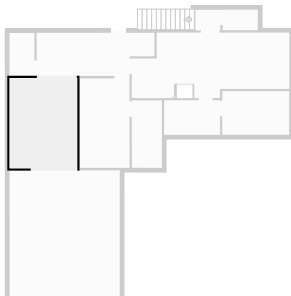

▼ **Closet**
Ground Floor

WIDTH: 1.32 m • LENGTH: 2.27 m
AREA: 2.98 m² • PERIMETER: 7.17 m

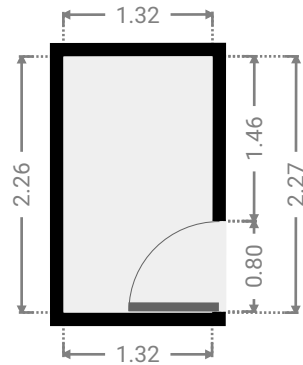
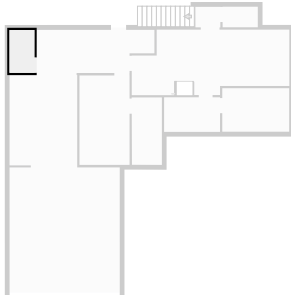

▼ **Bedroom**
Ground Floor

WIDTH: 2.65 m • LENGTH: 4.73 m
AREA: 12.53 m² • PERIMETER: 14.76 m

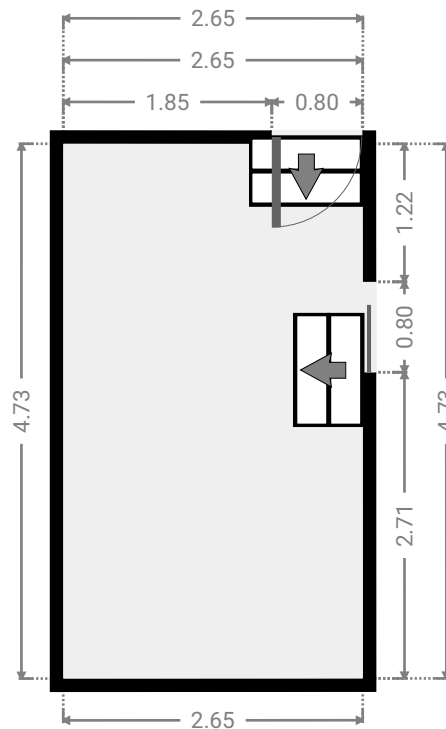
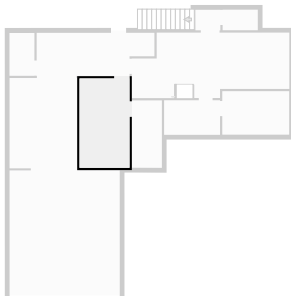

▼ **Closet**
Ground Floor

WIDTH: 1.61 m • LENGTH: 3.57 m
AREA: 5.67 m² • PERIMETER: 10.32 m

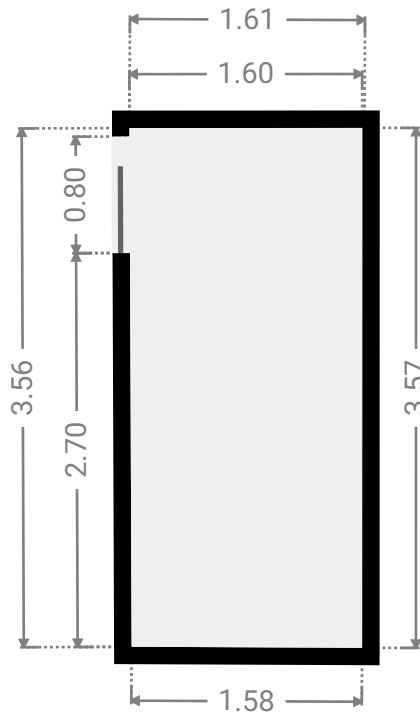
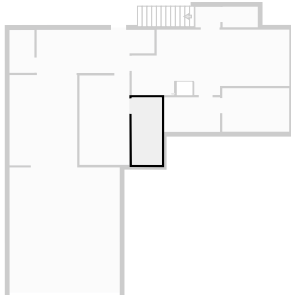

▼ **Other**
Ground Floor

WIDTH: 1.33 m • LENGTH: 1.09 m
AREA: 1.43 m² • PERIMETER: 4.81 m

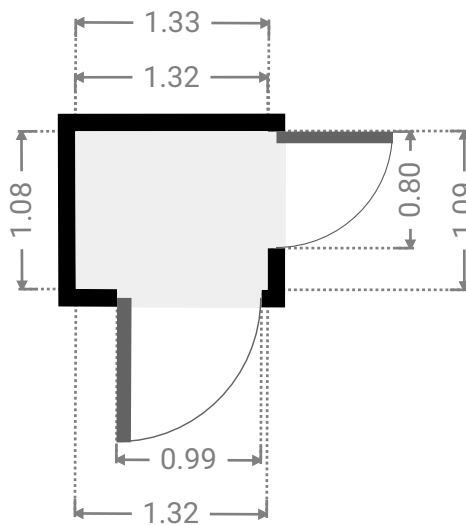
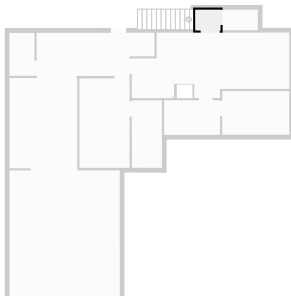

▼ Toilet
Ground Floor

WIDTH: 1.86 m • LENGTH: 1.09 m
AREA: 2.02 m² • PERIMETER: 5.90 m

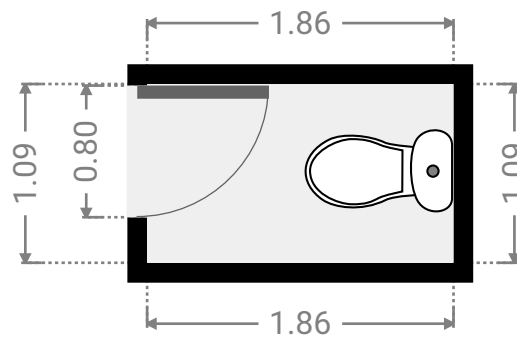
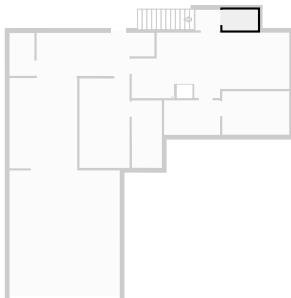

▼ Other
Ground Floor

WIDTH: 3.54 m • LENGTH: 2.30 m
AREA: 8.14 m² • PERIMETER: 11.68 m

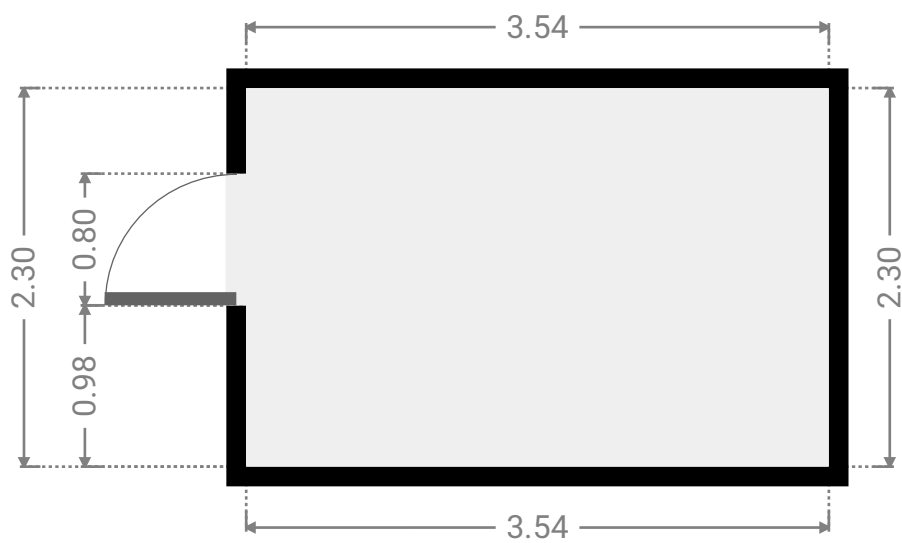
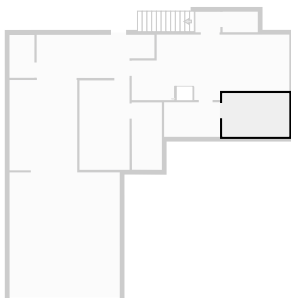

▼ **Garage**
Ground Floor

WIDTH: 5.83 m • LENGTH: 6.50 m
AREA: 37.89 m² • PERIMETER: 24.66 m

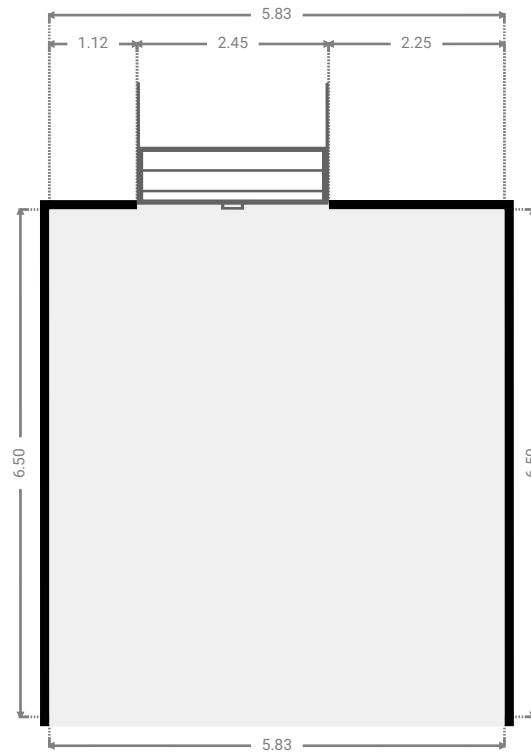

▼ 1st Floor

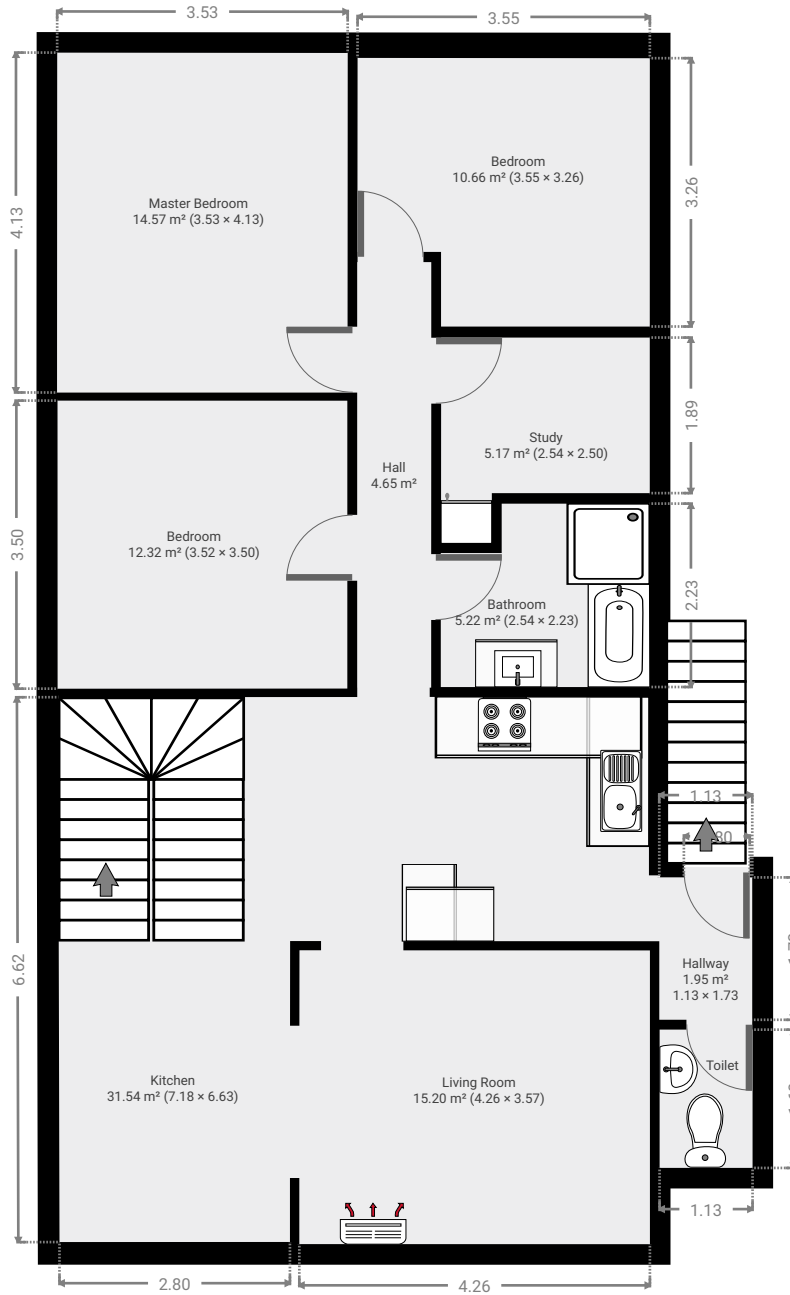

▼ Kitchen
1st Floor

WIDTH: 6.63 m • LENGTH: 7.18 m
AREA: 31.54 m² • PERIMETER: 27.59 m

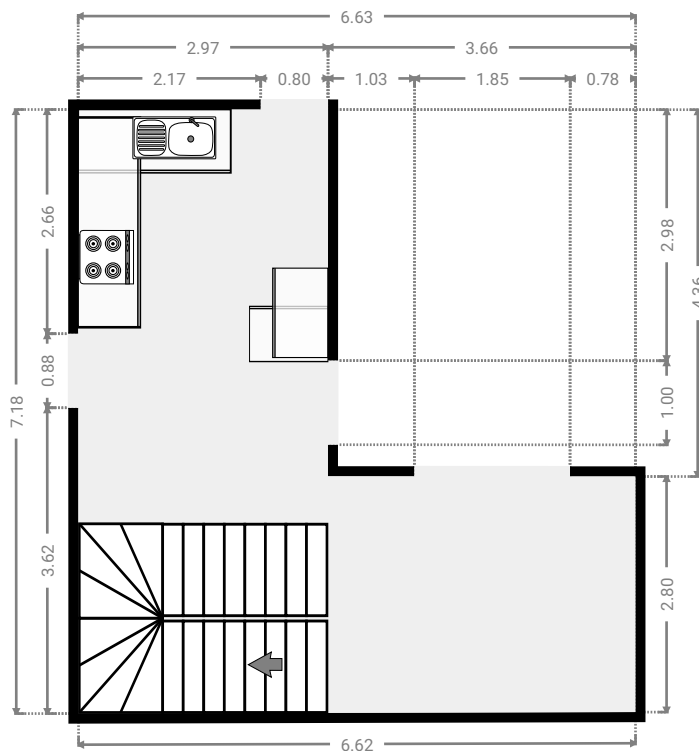
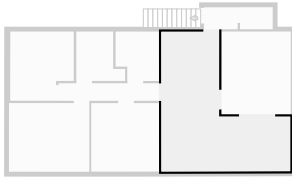

▼ Living Room
1st Floor

WIDTH: 3.57 m • LENGTH: 4.26 m
AREA: 15.20 m² • PERIMETER: 15.66 m

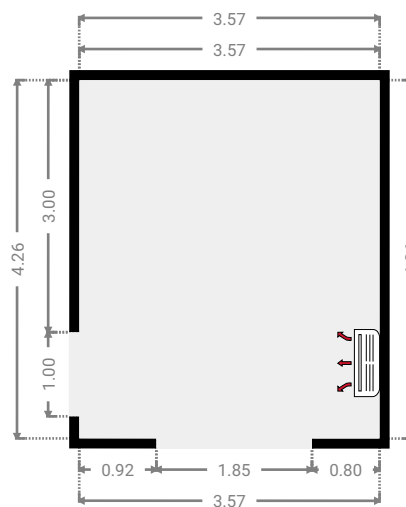
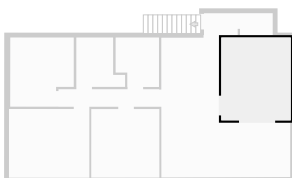

▼ **Hallway**
1st Floor

WIDTH: 1.73 m • LENGTH: 1.13 m
AREA: 1.95 m² • PERIMETER: 5.72 m

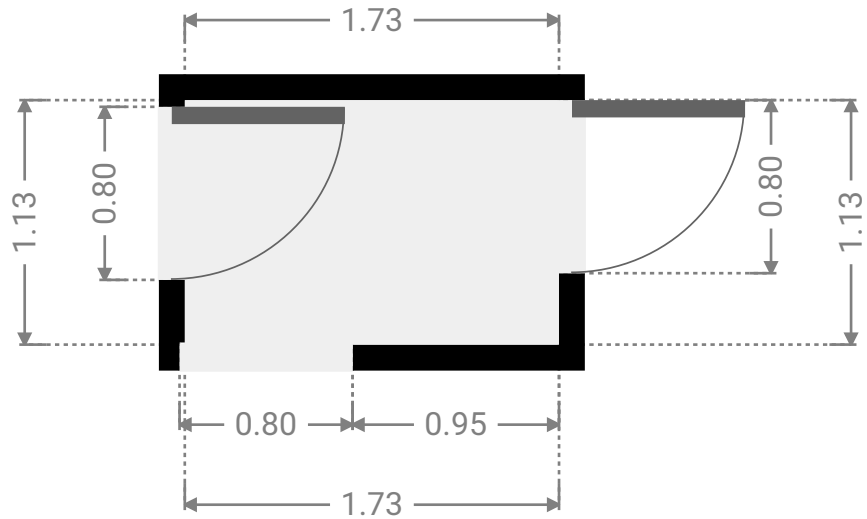
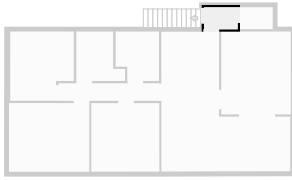

▼ **Toilet**
1st Floor

WIDTH: 1.68 m • LENGTH: 1.13 m
AREA: 1.90 m² • PERIMETER: 5.62 m

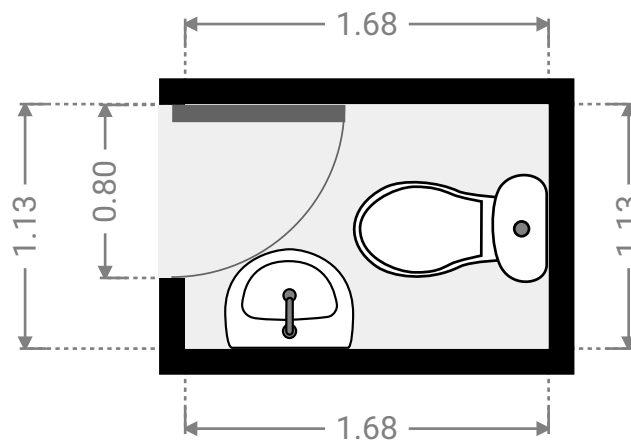
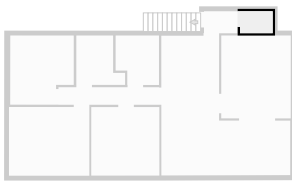

▼ **Hall**
1st Floor

WIDTH: 5.17 m • LENGTH: 0.90 m
AREA: 4.65 m² • PERIMETER: 12.14 m

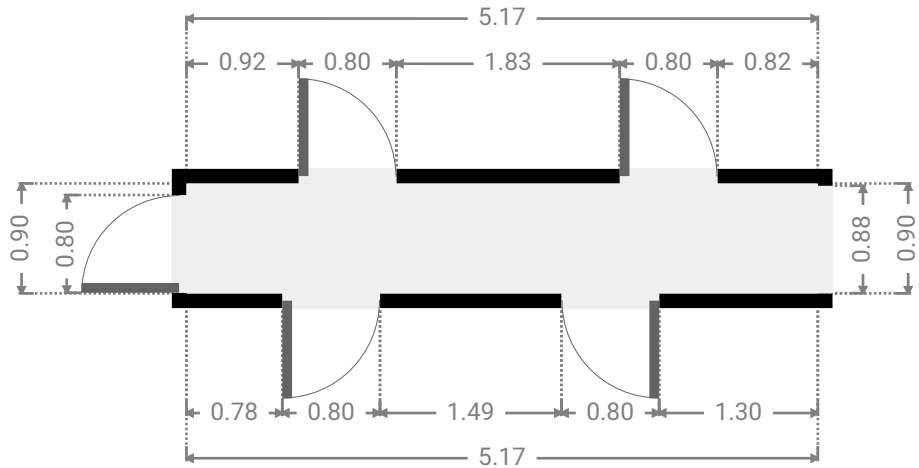
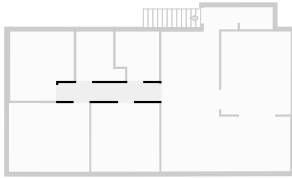

▼ **Bathroom**
1st Floor

WIDTH: 2.23 m • LENGTH: 2.54 m
AREA: 5.22 m² • PERIMETER: 9.54 m

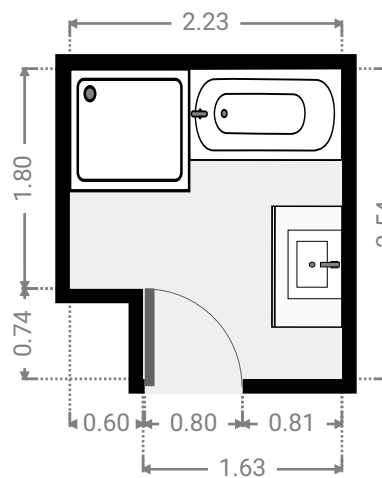
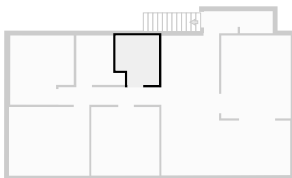

▼ **Bedroom**
1st Floor

WIDTH: 3.50 m • LENGTH: 3.52 m
AREA: 12.32 m² • PERIMETER: 14.04 m

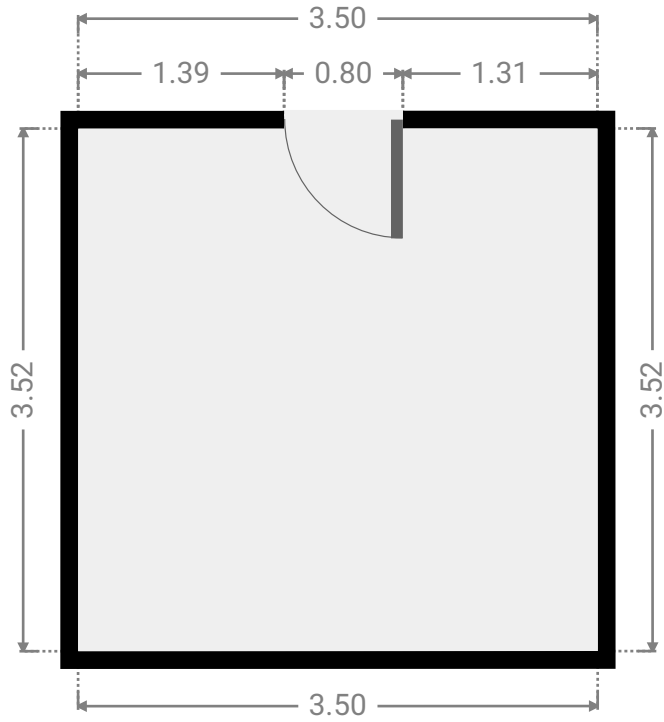
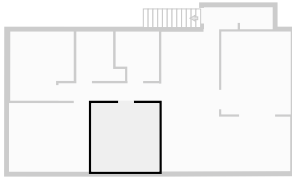

▼ **Study**
1st Floor

WIDTH: 2.50 m • LENGTH: 2.54 m
AREA: 5.17 m² • PERIMETER: 10.08 m

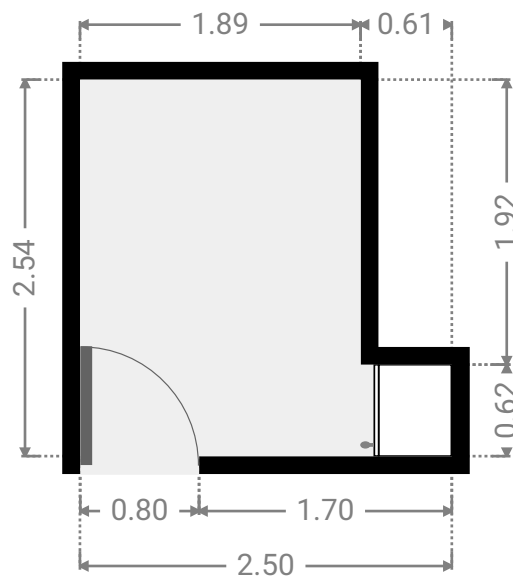
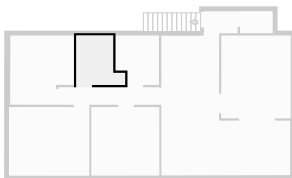

▼ **Bedroom**
1st Floor

WIDTH: 3.26 m • LENGTH: 3.55 m
AREA: 10.66 m² • PERIMETER: 13.63 m

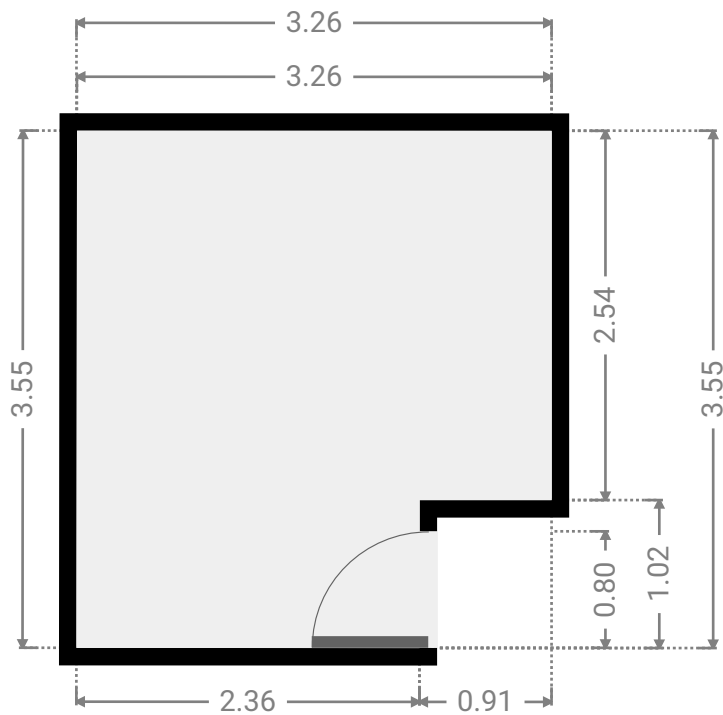
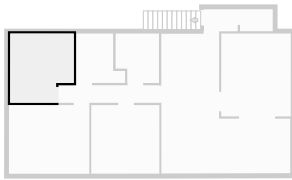

▼ **Master Bedroom**
1st Floor

WIDTH: 4.13 m • LENGTH: 3.53 m
AREA: 14.57 m² • PERIMETER: 15.32 m

