

# 235 Flannigan Street

Created on  
2021-08-05

Floors  
2

▼ Ground Floor

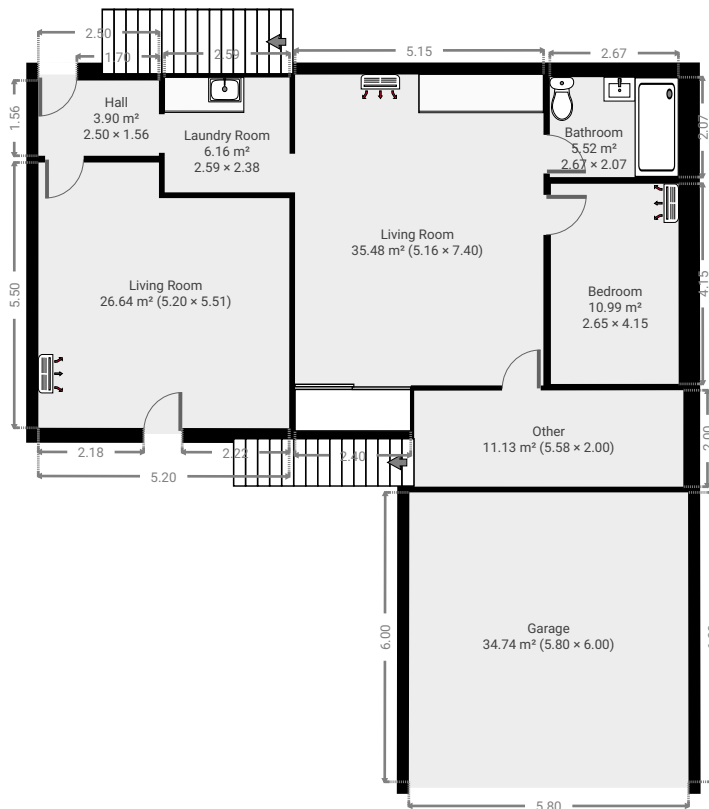
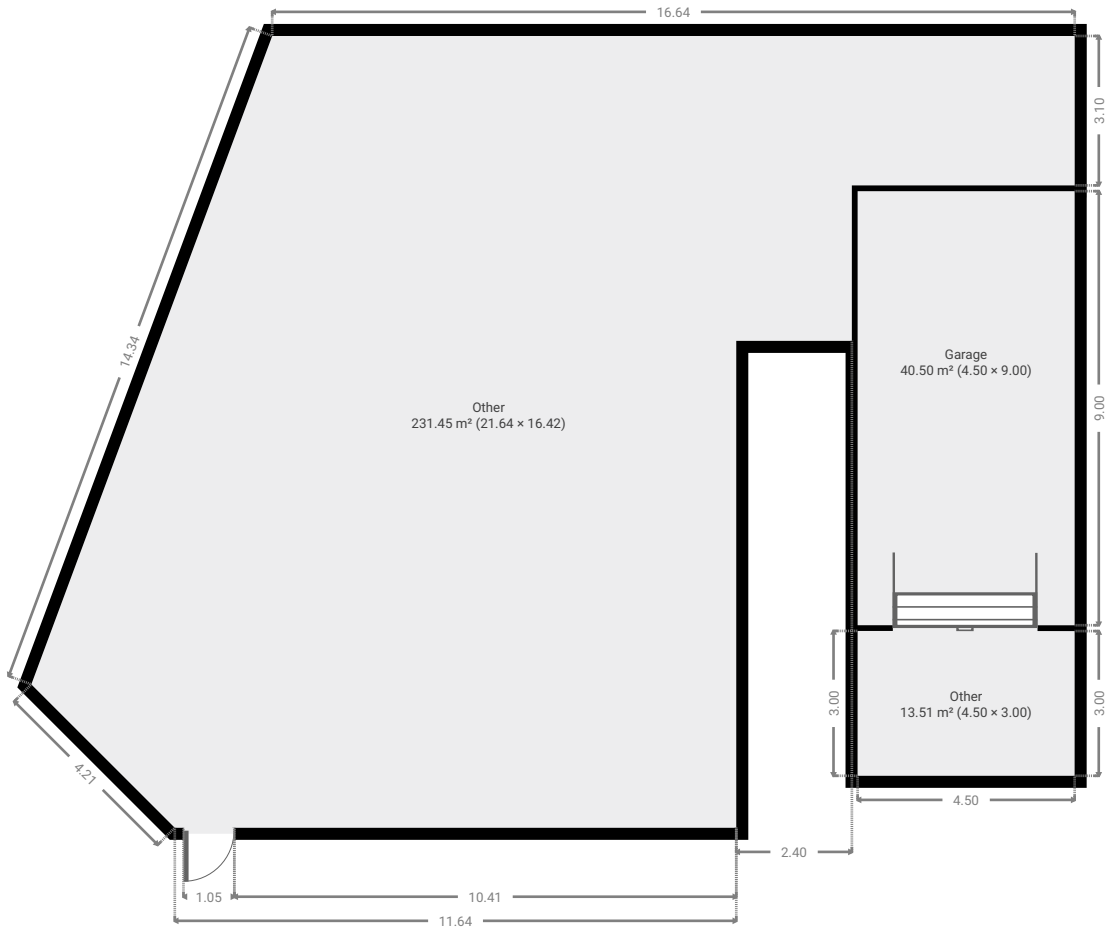

▼ **Living Room**  
Ground Floor

WIDTH: 5.16 m • LENGTH: 7.40 m  
AREA: 35.48 m<sup>2</sup> • PERIMETER: 25.09 m

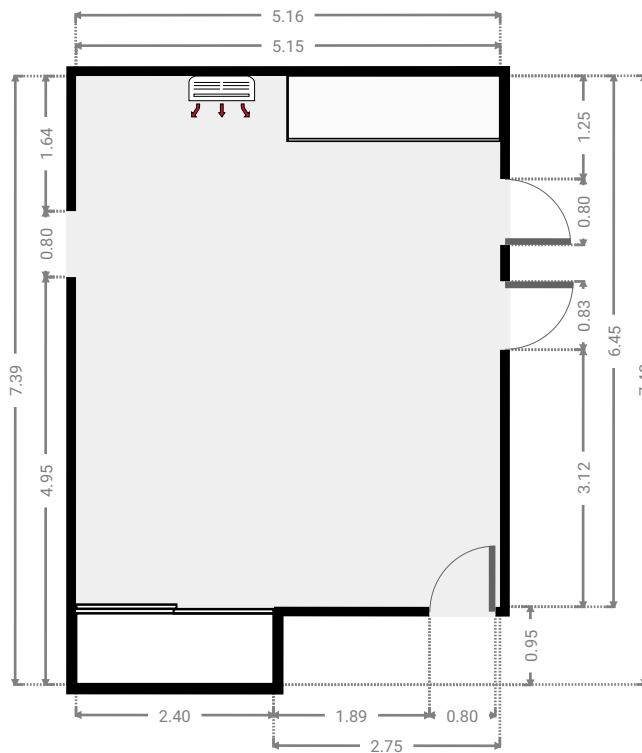
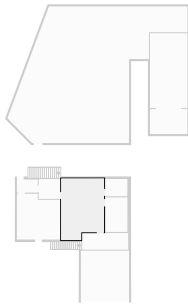

▼ **Bathroom**  
Ground Floor

WIDTH: 2.67 m • LENGTH: 2.07 m  
AREA: 5.52 m<sup>2</sup> • PERIMETER: 9.47 m

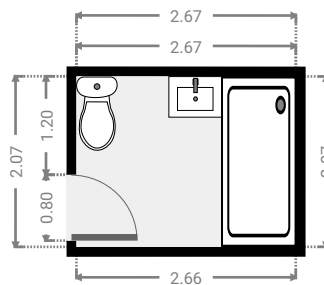
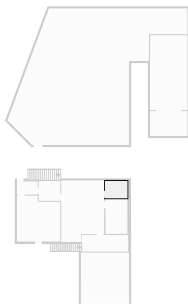

▼ Laundry Room  
Ground Floor

WIDTH: 2.59 m • LENGTH: 2.38 m  
AREA: 6.16 m<sup>2</sup> • PERIMETER: 9.94 m

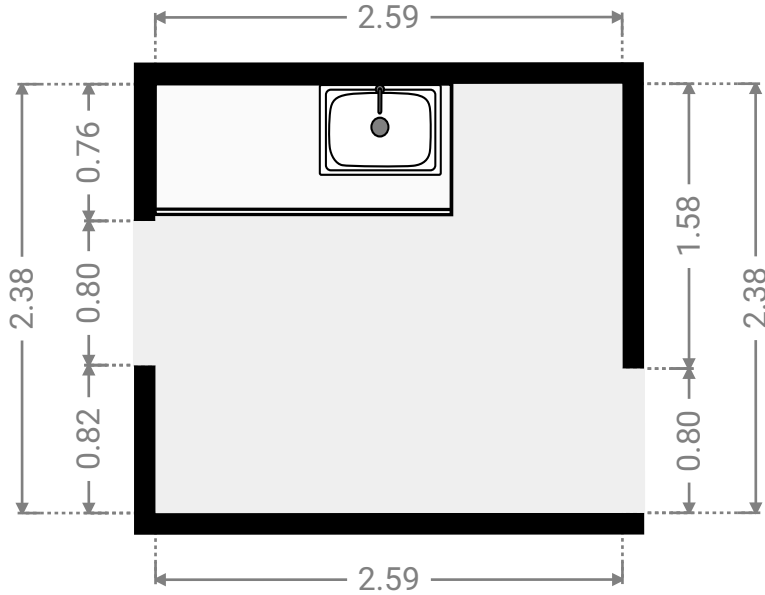

▼ Hall  
Ground Floor

WIDTH: 2.50 m • LENGTH: 1.56 m  
AREA: 3.90 m<sup>2</sup> • PERIMETER: 8.12 m

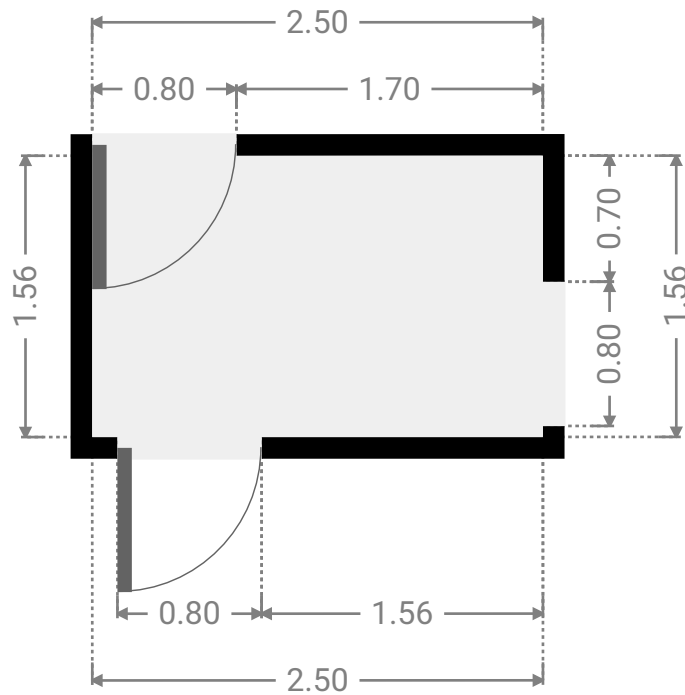

▼ Living Room  
Ground Floor

WIDTH: 5.20 m • LENGTH: 5.51 m  
AREA: 26.64 m<sup>2</sup> • PERIMETER: 21.41 m

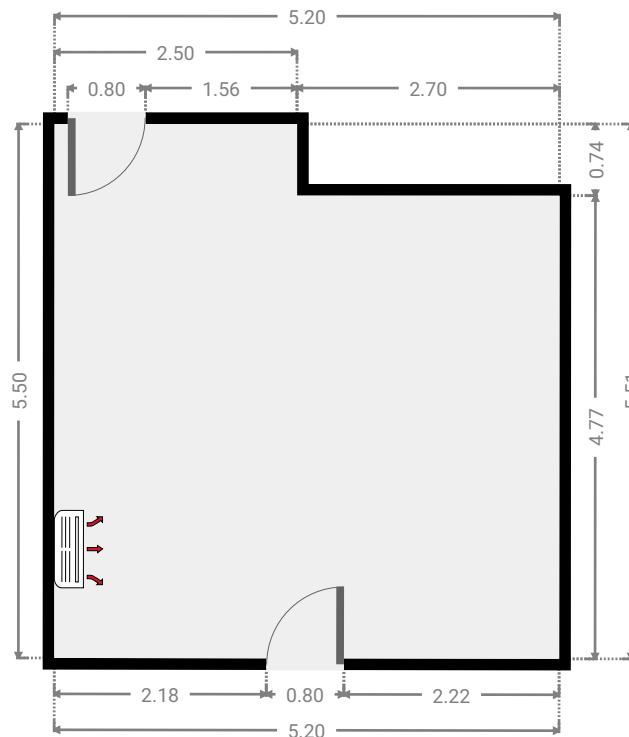
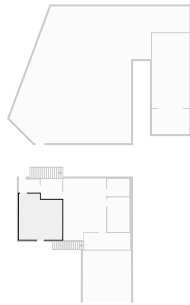

▼ Bedroom  
Ground Floor

WIDTH: 2.65 m • LENGTH: 4.15 m  
AREA: 10.99 m<sup>2</sup> • PERIMETER: 13.60 m

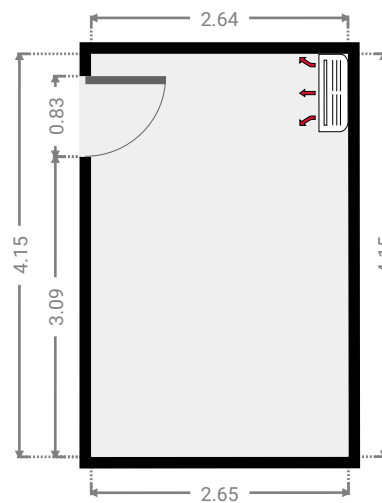
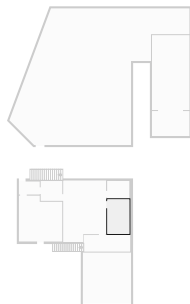

▼ **Garage**  
Ground Floor

WIDTH: 4.50 m • LENGTH: 9.00 m  
AREA: 40.50 m<sup>2</sup> • PERIMETER: 27.00 m

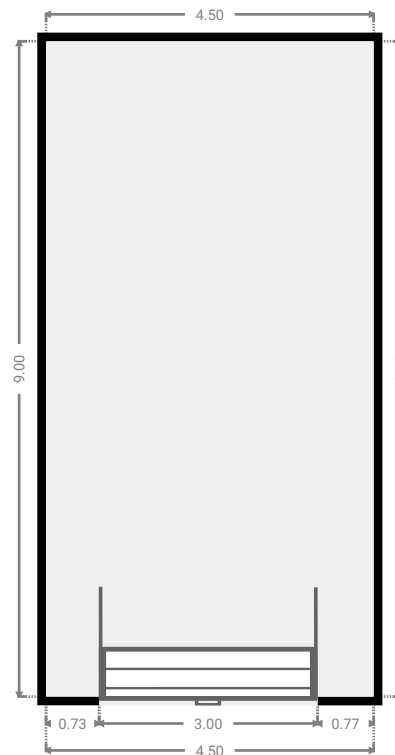
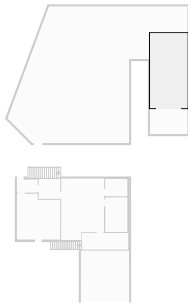

▼ **Other**  
Ground Floor

WIDTH: 4.50 m • LENGTH: 3.00 m  
AREA: 13.51 m<sup>2</sup> • PERIMETER: 15.00 m

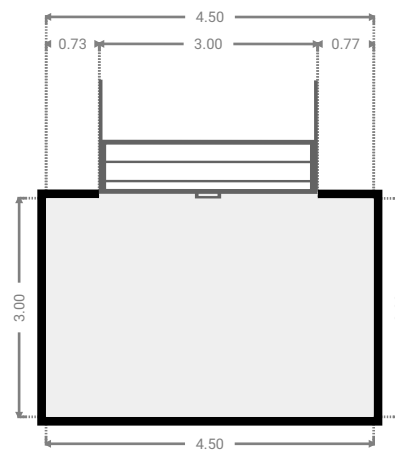
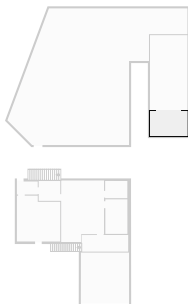

▼ Other  
Ground Floor

WIDTH: 21.64 m • LENGTH: 16.42 m  
AREA: 231.45 m<sup>2</sup> • PERIMETER: 70.27 m

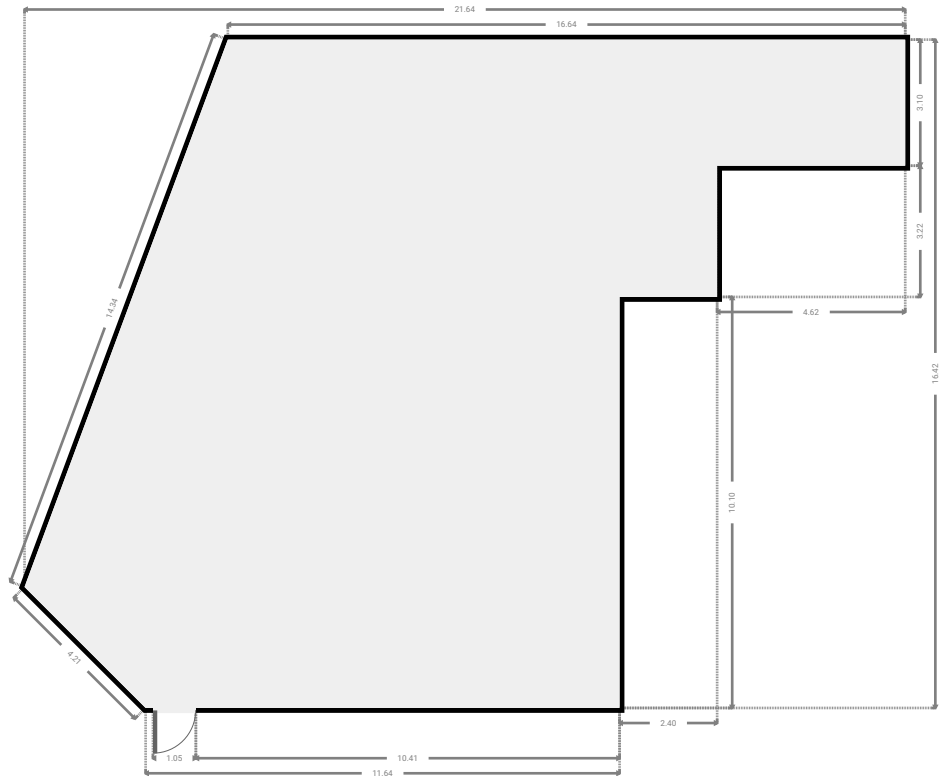
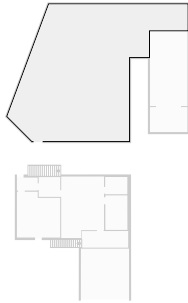

▼ Other  
Ground Floor

WIDTH: 5.58 m • LENGTH: 2.00 m  
AREA: 11.13 m<sup>2</sup> • PERIMETER: 15.15 m

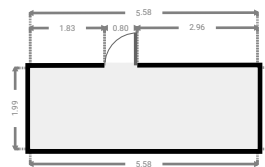

▼ **Garage**  
Ground Floor

WIDTH: 5.80 m • LENGTH: 6.00 m  
AREA: 34.74 m<sup>2</sup> • PERIMETER: 23.58 m

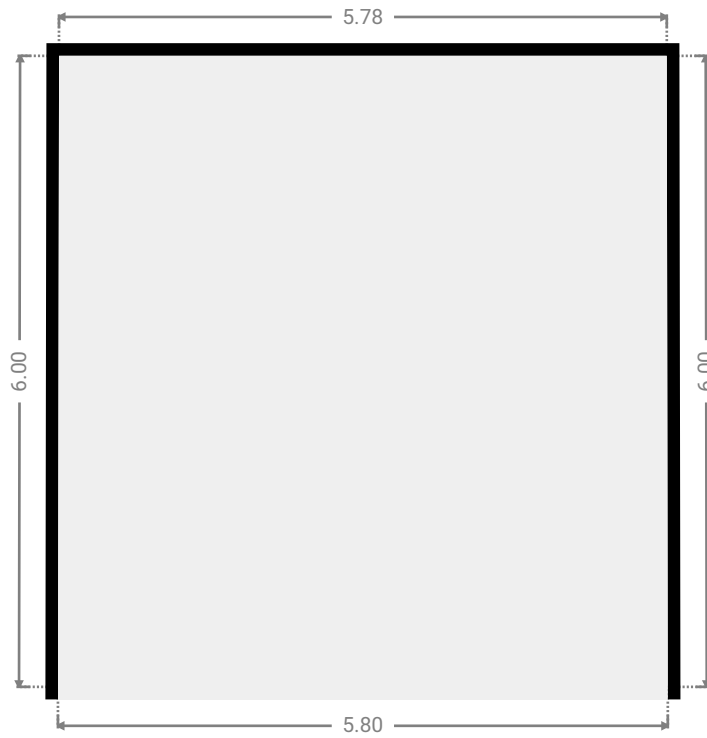
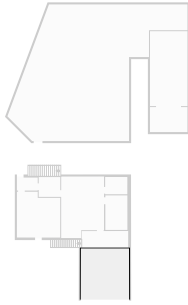



## ▼ 1st Floor

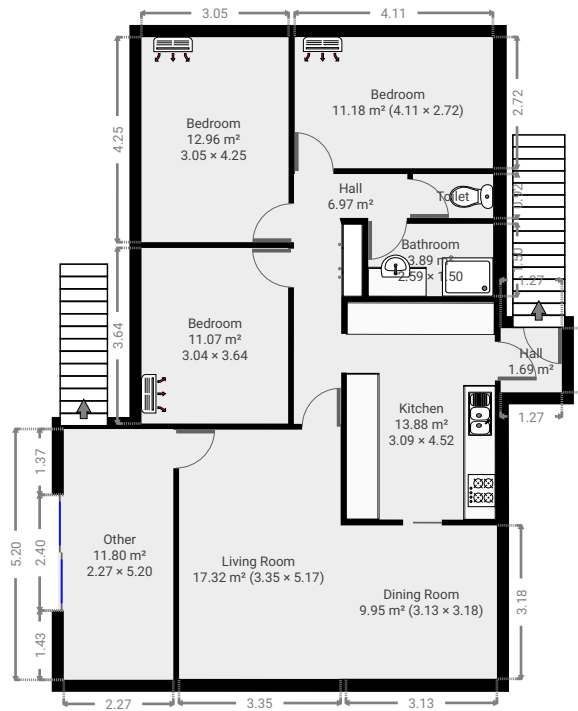

▼ Other  
1st Floor

WIDTH: 5.20 m • LENGTH: 2.27 m  
AREA: 11.80 m<sup>2</sup> • PERIMETER: 14.94 m

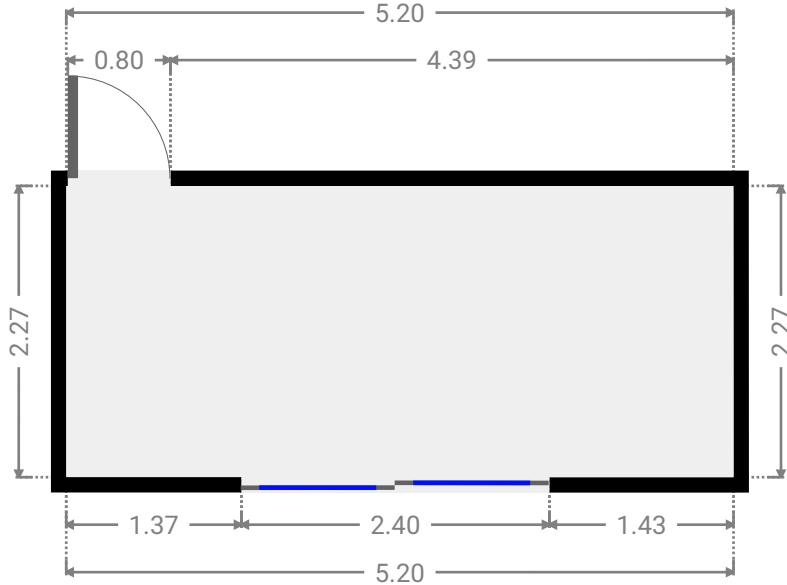
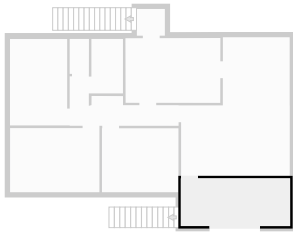

▼ Living Room  
1st Floor

WIDTH: 5.17 m • LENGTH: 3.35 m  
AREA: 17.32 m<sup>2</sup> • PERIMETER: 17.04 m

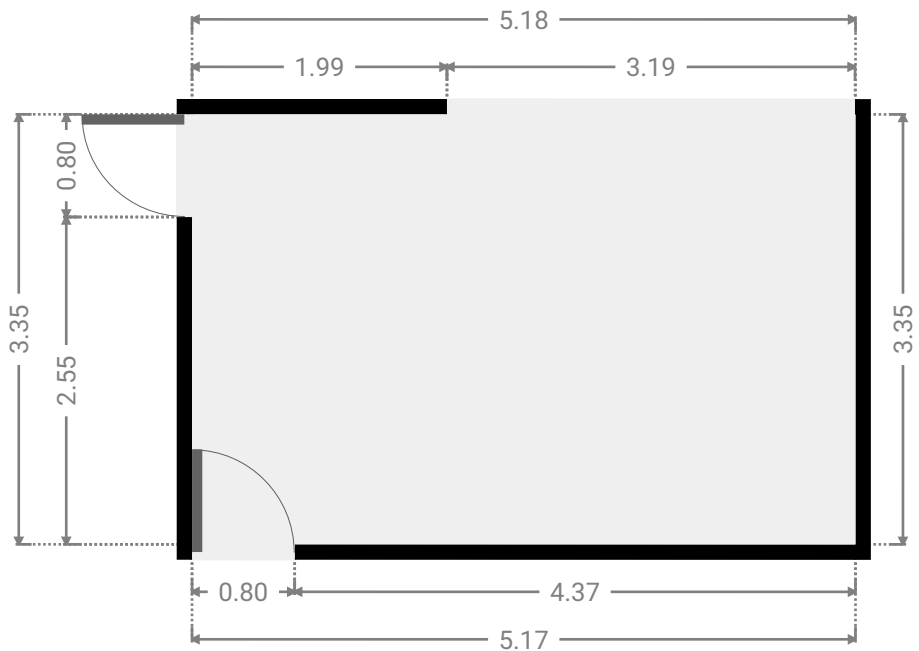
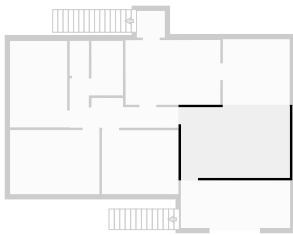

▼ **Dining Room**  
1st Floor

WIDTH: 3.18 m • LENGTH: 3.13 m  
AREA: 9.95 m<sup>2</sup> • PERIMETER: 12.62 m

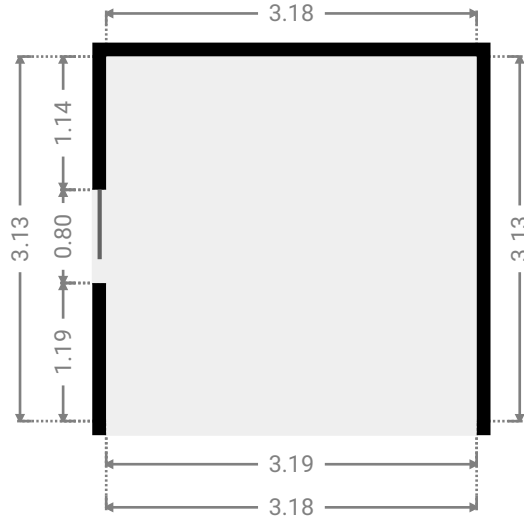
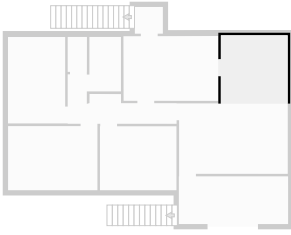

▼ **Hall**  
1st Floor

WIDTH: 5.18 m • LENGTH: 2.35 m  
AREA: 6.97 m<sup>2</sup> • PERIMETER: 15.96 m

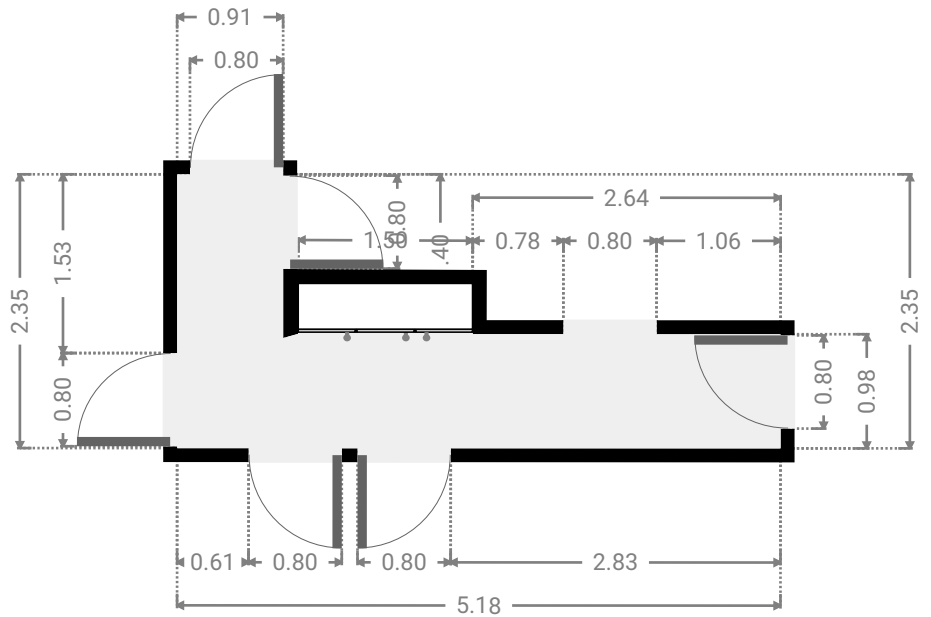
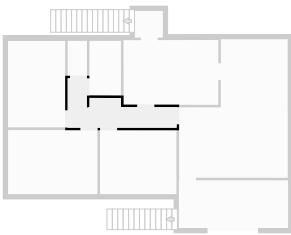

▼ **Bedroom**  
1st Floor

WIDTH: 3.64 m • LENGTH: 3.04 m  
AREA: 11.07 m<sup>2</sup> • PERIMETER: 13.36 m

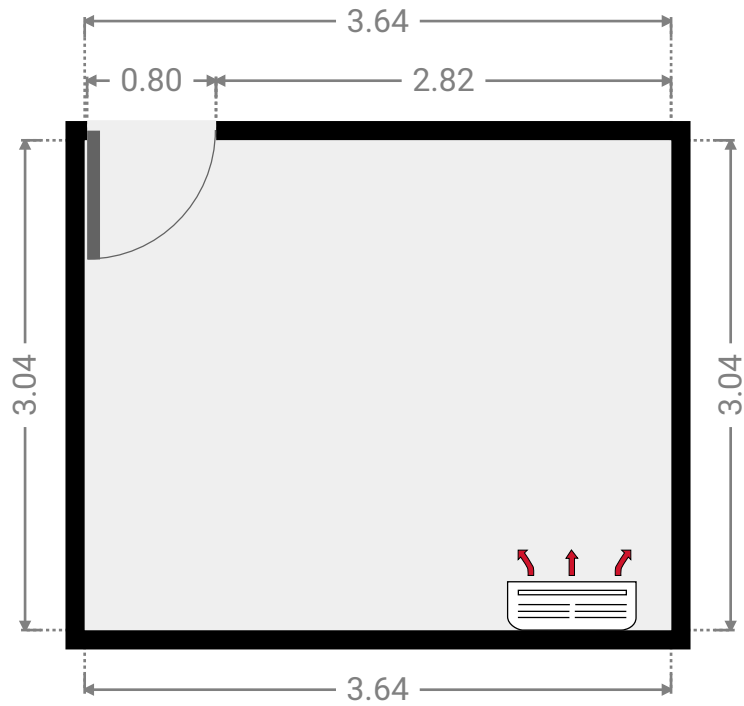
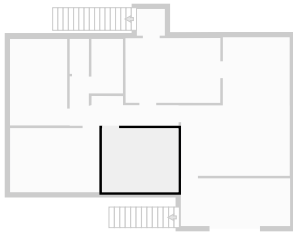

▼ **Bedroom**  
1st Floor

WIDTH: 4.25 m • LENGTH: 3.05 m  
AREA: 12.96 m<sup>2</sup> • PERIMETER: 14.60 m

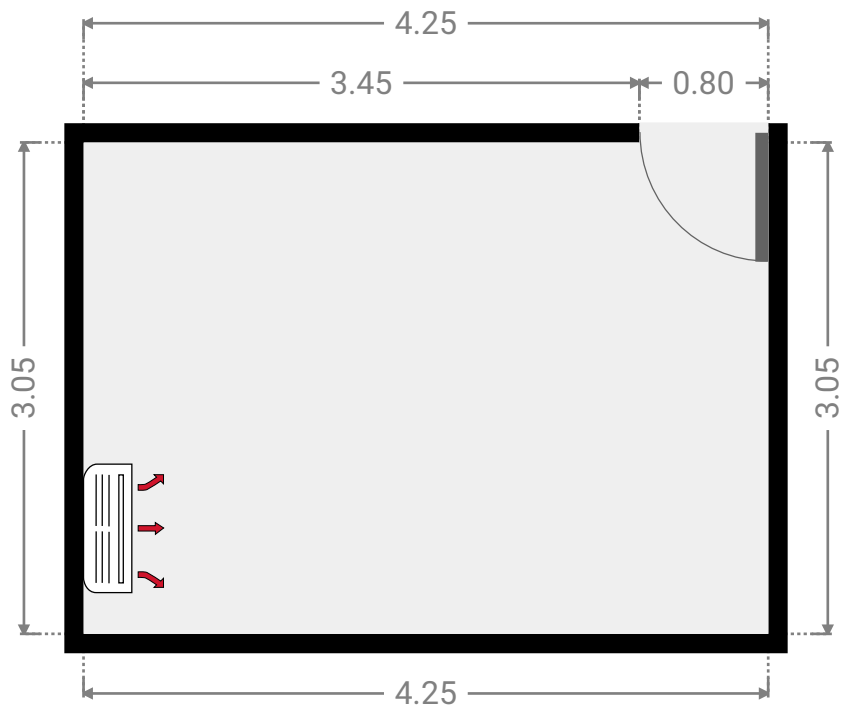
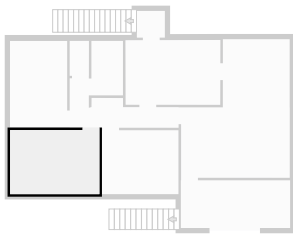

▼ **Bedroom**  
1st Floor

WIDTH: 2.72 m • LENGTH: 4.11 m  
AREA: 11.18 m<sup>2</sup> • PERIMETER: 13.66 m

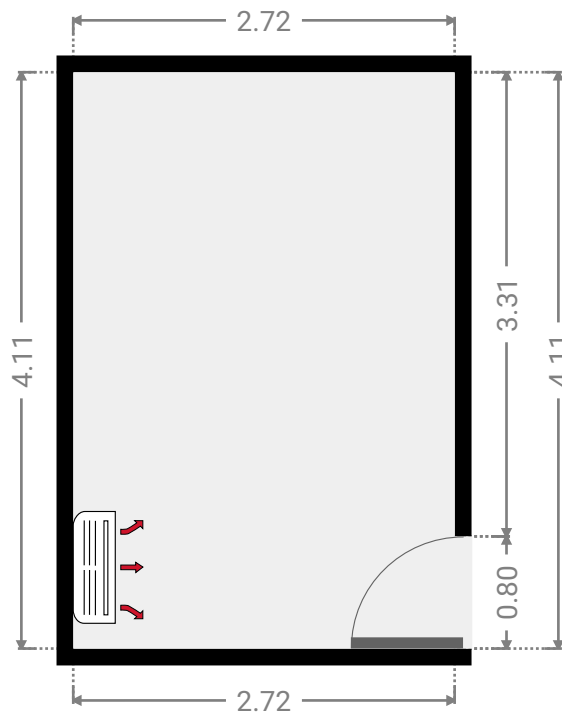
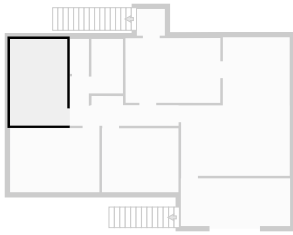

▼ **Toilet**  
1st Floor

WIDTH: 0.91 m • LENGTH: 1.67 m  
AREA: 1.52 m<sup>2</sup> • PERIMETER: 5.15 m

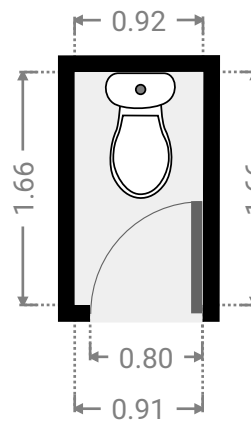

▼ **Bathroom**  
1st Floor

WIDTH: 1.50 m • LENGTH: 2.59 m  
AREA: 3.89 m<sup>2</sup> • PERIMETER: 8.18 m

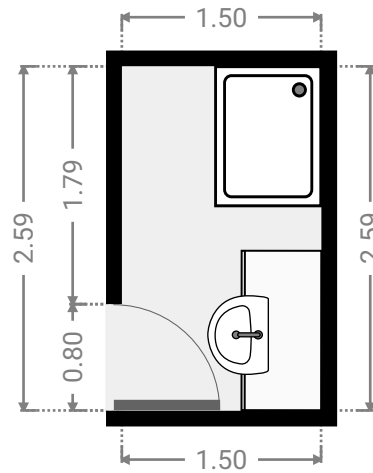
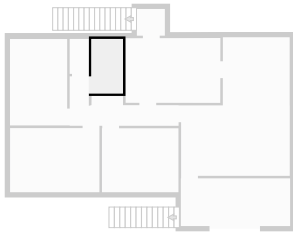

▼ **Kitchen**  
1st Floor

WIDTH: 4.52 m • LENGTH: 3.09 m  
AREA: 13.88 m<sup>2</sup> • PERIMETER: 15.17 m

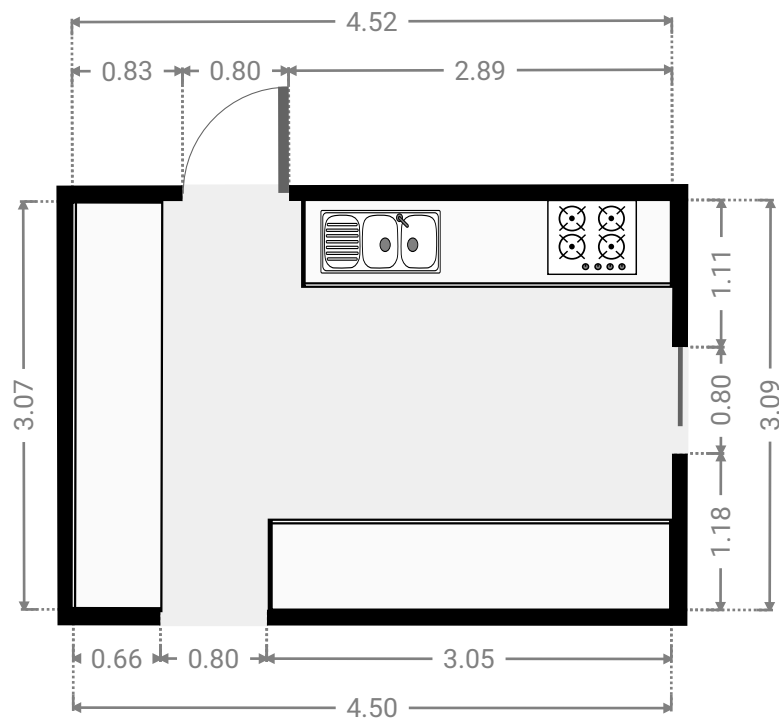
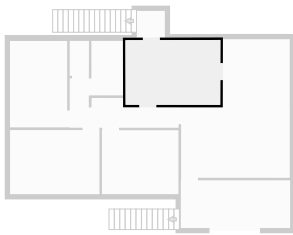

▼ **Hall**  
1st Floor

WIDTH: 1.33 m • LENGTH: 1.27 m  
AREA: 1.69 m<sup>2</sup> • PERIMETER: 5.20 m

