

23 Rockhampton Road , Yeppoon

SUBMITTED BY

Ray White Rockhampton Casey
stockers@cqoz.com

CREATED ON

2016-11-10

Floors

1

FLOORS: 1

▼ Ground Floor



THIS FLOORPLAN IS PROVIDED WITHOUT WARRANTY OF ANY KIND. SENSOPIA DISCLAIMS ANY WARRANTY INCLUDING, WITHOUT LIMITATION, SATISFACTORY QUALITY OR ACCURACY OF DIMENSIONS.

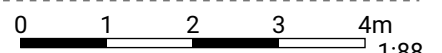

FLOORS: 1

▼ **Bathroom**
Ground Floor

WIDTH: 2.20 m • LENGTH: 3.04 m
AREA: 6.68 m² • PERIMETER: 10.48 m

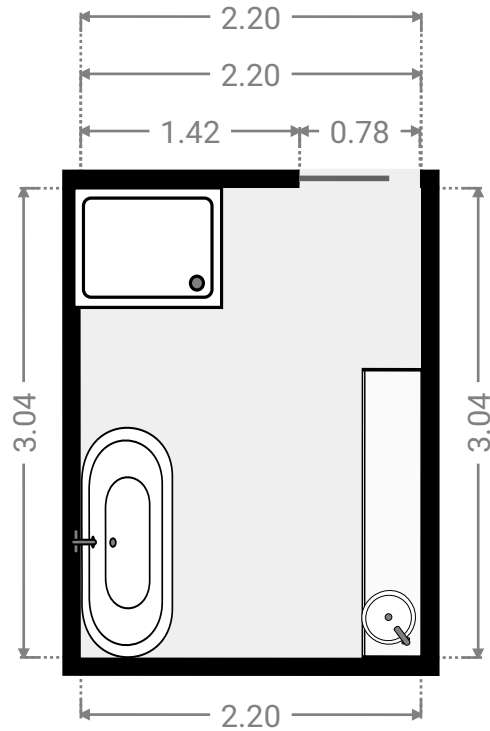
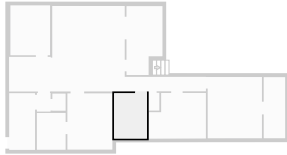

▼ **Bedroom**
Ground Floor

WIDTH: 2.66 m • LENGTH: 3.35 m
AREA: 8.91 m² • PERIMETER: 12.02 m

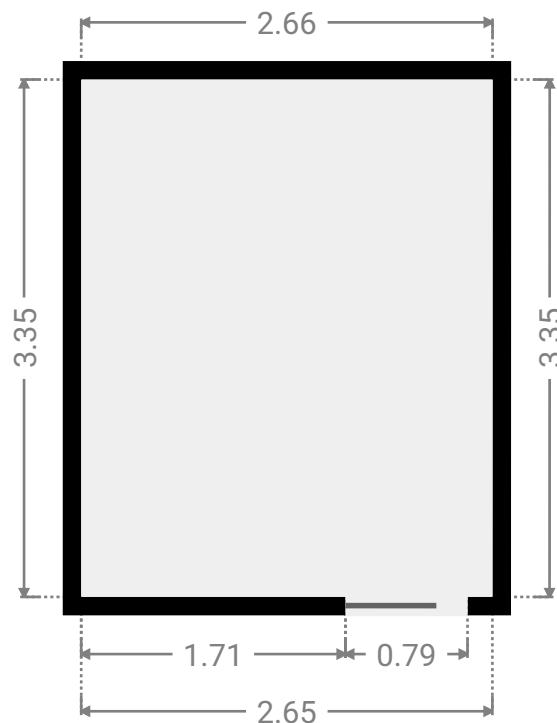

FLOORS: 1

▼ **Bedroom**
Ground Floor

WIDTH: 3.84 m • LENGTH: 3.07 m • CEILING HEIGHT: 2.17 m
AREA: 10.66 m² • PERIMETER: 13.79 m

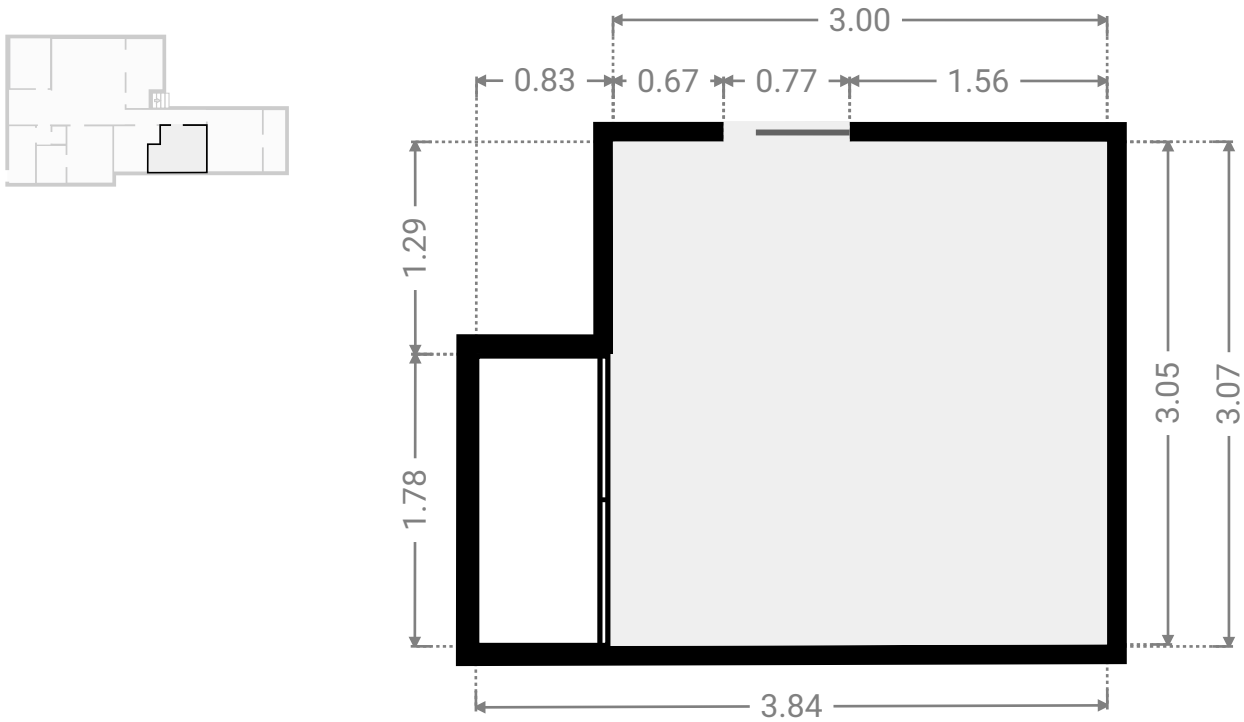

▼ **Dining Room**
Ground Floor

WIDTH: 2.79 m • LENGTH: 2.33 m
AREA: 6.49 m² • PERIMETER: 10.24 m

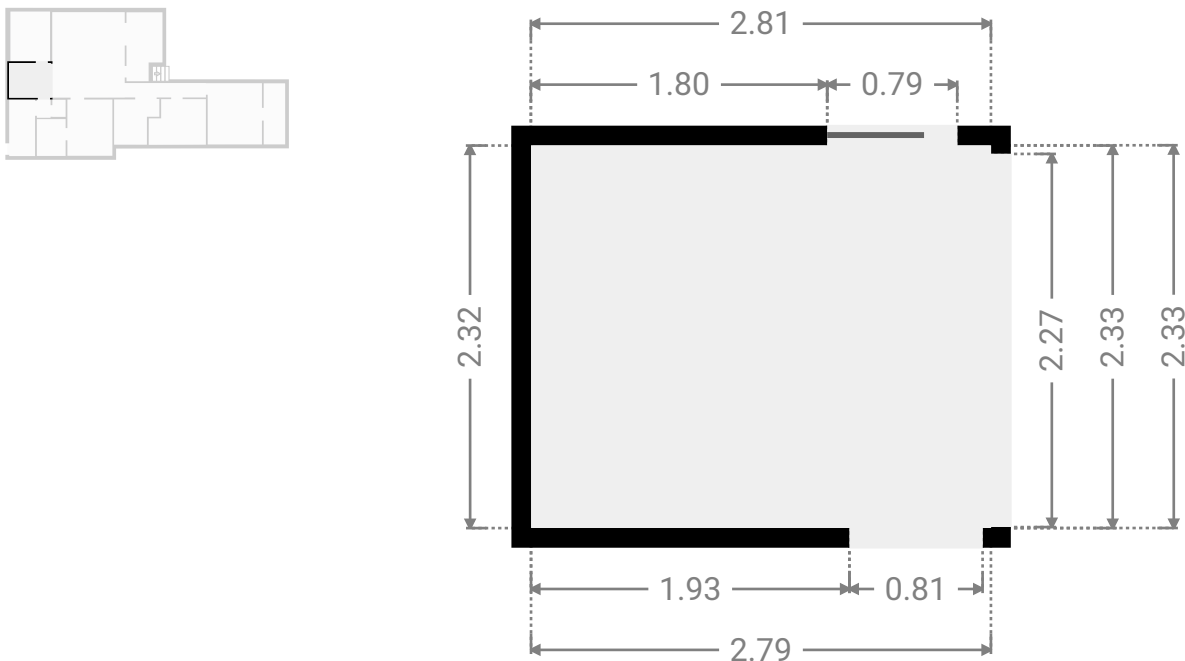

FLOORS: 1

▼ **Hall**
Ground Floor

WIDTH: 0.92 m • LENGTH: 1.25 m
AREA: 1.15 m² • PERIMETER: 4.34 m

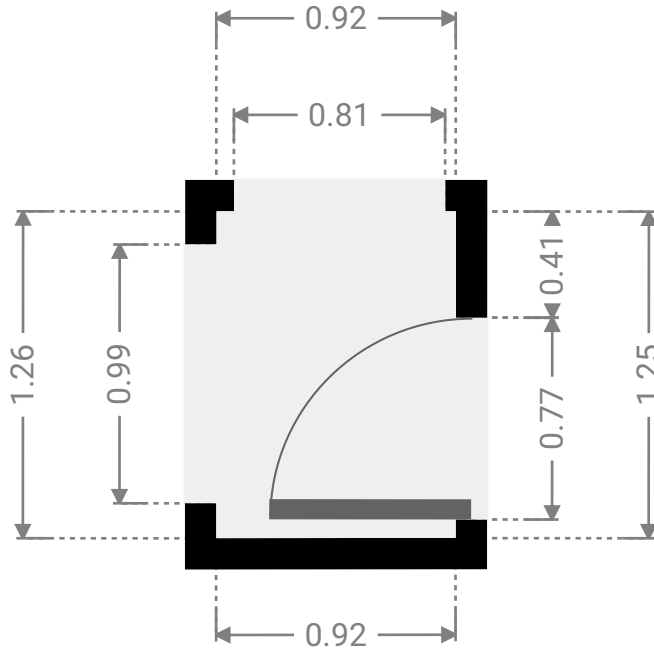
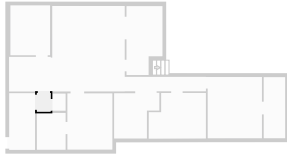

▼ **Closet**
Ground Floor

WIDTH: 0.89 m • LENGTH: 1.14 m
AREA: 1.02 m² • PERIMETER: 4.07 m

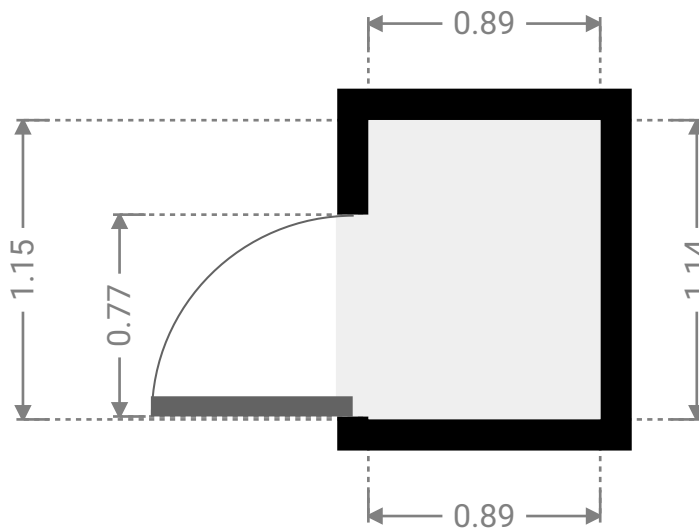

FLOORS: 1

▼ **Hall**
Ground Floor

WIDTH: 5.33 m • LENGTH: 0.97 m
AREA: 5.16 m² • PERIMETER: 12.59 m

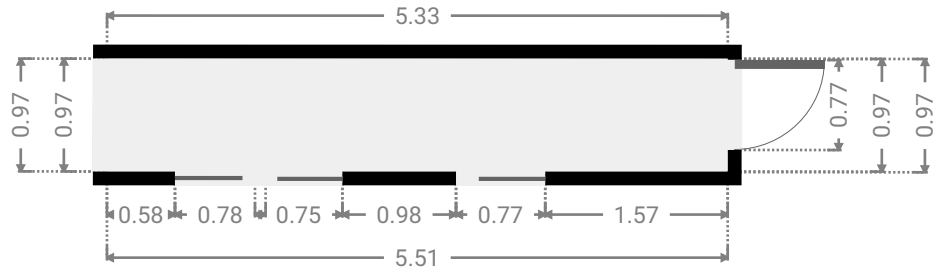
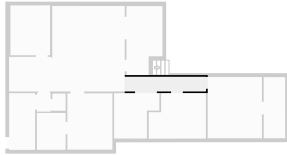

▼ **Kitchen**
Ground Floor

WIDTH: 3.02 m • LENGTH: 3.77 m
AREA: 11.39 m² • PERIMETER: 13.58 m

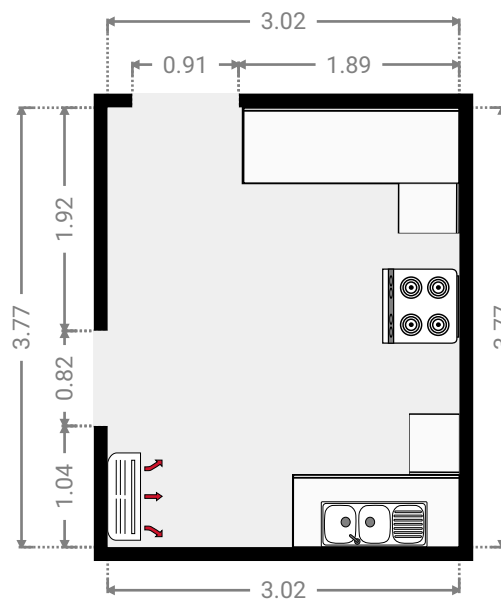
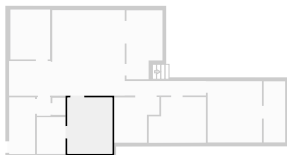

FLOORS: 1

▼ **Laundry Room**
Ground Floor

WIDTH: 1.74 m • LENGTH: 3.81 m
AREA: 6.61 m² • PERIMETER: 11.09 m

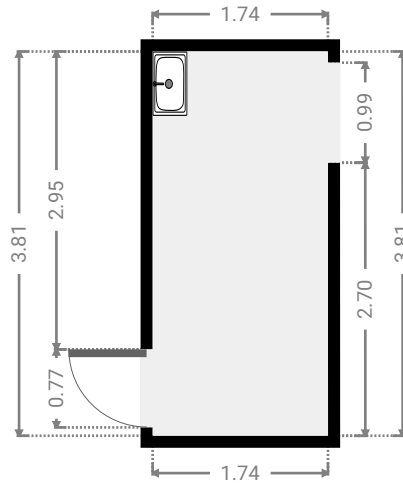
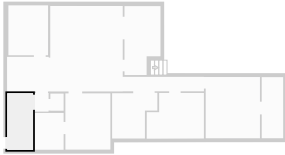

▼ **Living Room**
Ground Floor

WIDTH: 4.87 m • LENGTH: 5.73 m
AREA: 27.90 m² • PERIMETER: 21.20 m

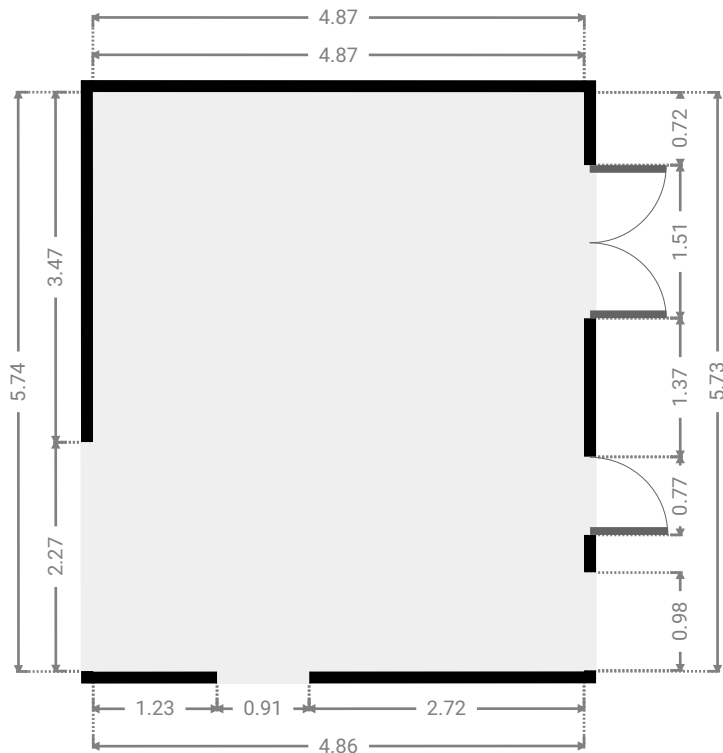
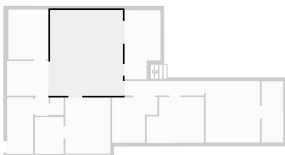

FLOORS: 1

▼ **Pantry**
Ground Floor

WIDTH: 1.93 m • LENGTH: 2.47 m
AREA: 4.76 m² • PERIMETER: 8.80 m

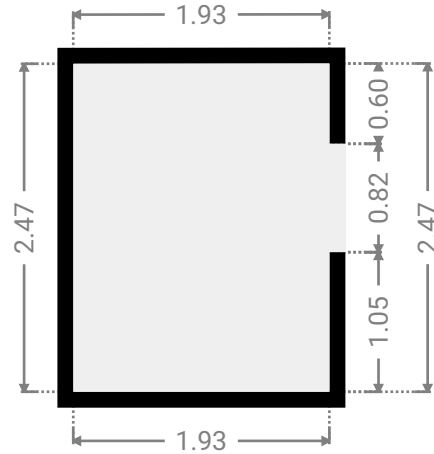

▼ **Patio**
Ground Floor

WIDTH: 2.41 m • LENGTH: 4.63 m • CEILING HEIGHT: 2.17 m
AREA: 9.98 m² • PERIMETER: 14.07 m

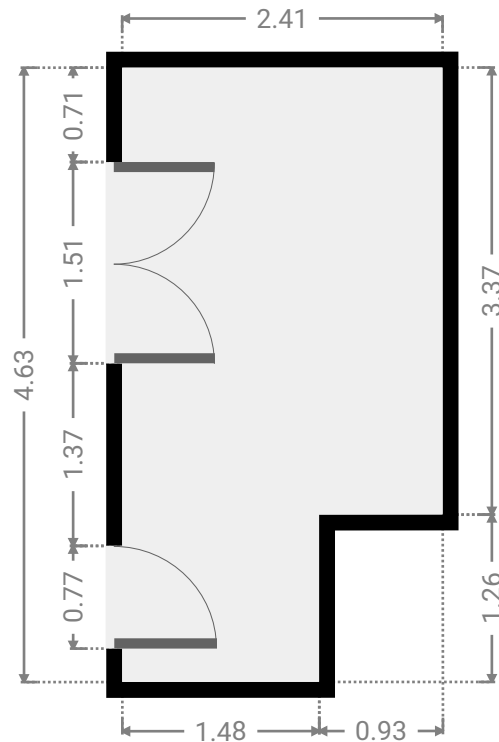
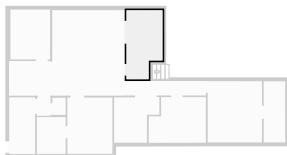

FLOORS: 1

▼ **Primary Bedroom**
Ground Floor

WIDTH: 3.64 m • LENGTH: 4.11 m
AREA: 14.96 m² • PERIMETER: 15.50 m

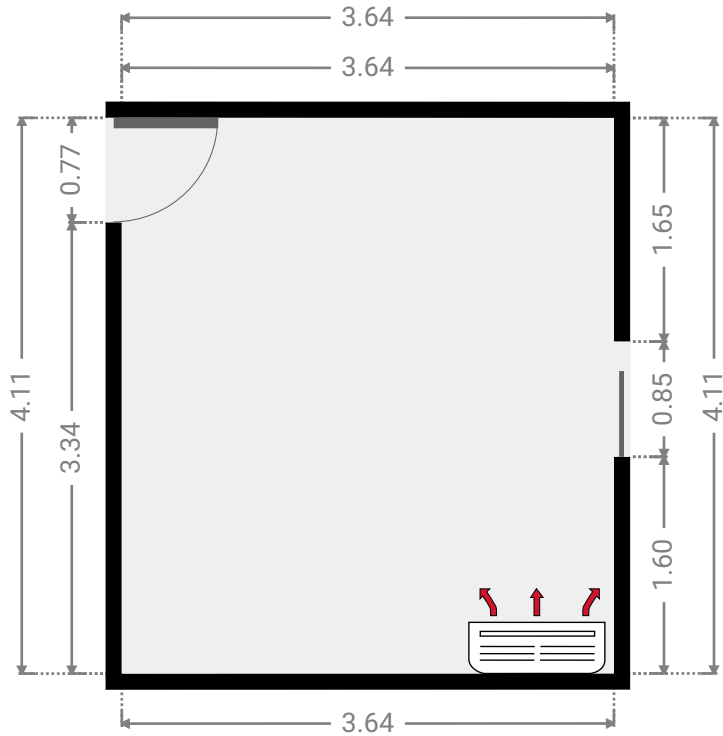
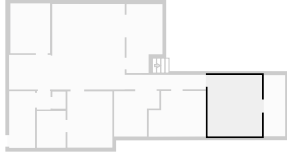

▼ **WIR**
Ground Floor

WIDTH: 1.44 m • LENGTH: 4.10 m
AREA: 5.90 m² • PERIMETER: 11.07 m

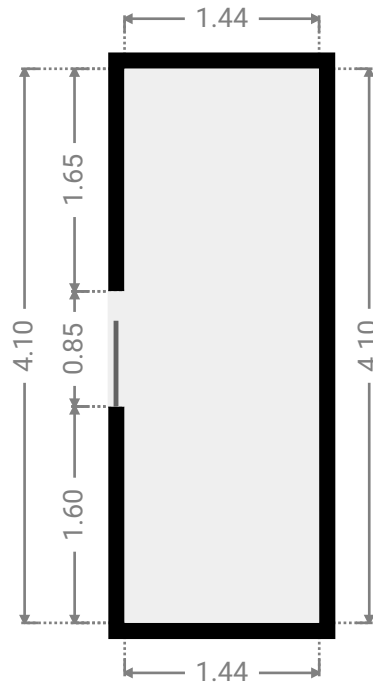

FLOORS: 1

▼ **Toilet**
Ground Floor

WIDTH: 1.12 m • LENGTH: 1.19 m
AREA: 1.33 m² • PERIMETER: 4.61 m

