

229A Murray street

SUBMITTED BY
Ray White Rockhampton Casey
stockers@cqoz.com

CREATED ON
2022-02-28

Floors
2

▼ Ground Floor

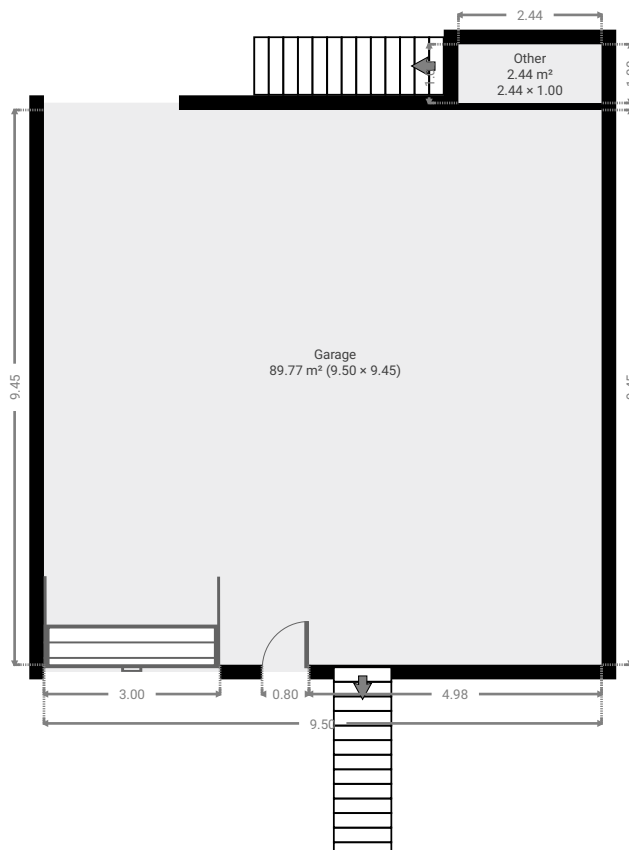
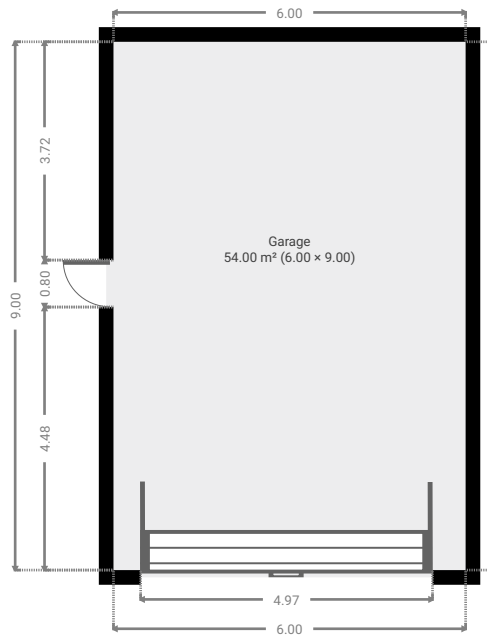

▼ **Garage**
Ground Floor

WIDTH: 9.50 m • LENGTH: 9.45 m
AREA: 89.77 m² • PERIMETER: 37.90 m

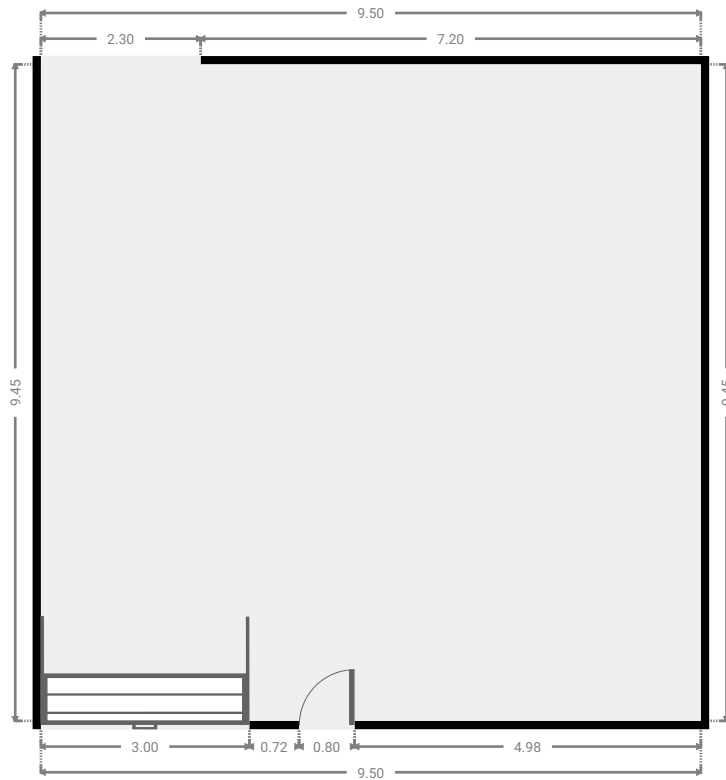

▼ **Other**
Ground Floor

WIDTH: 2.44 m • LENGTH: 1.00 m
AREA: 2.44 m² • PERIMETER: 6.88 m

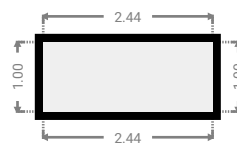

▼ Garage
Ground Floor

WIDTH: 6.00 m • LENGTH: 9.00 m
AREA: 54.00 m² • PERIMETER: 30.00 m

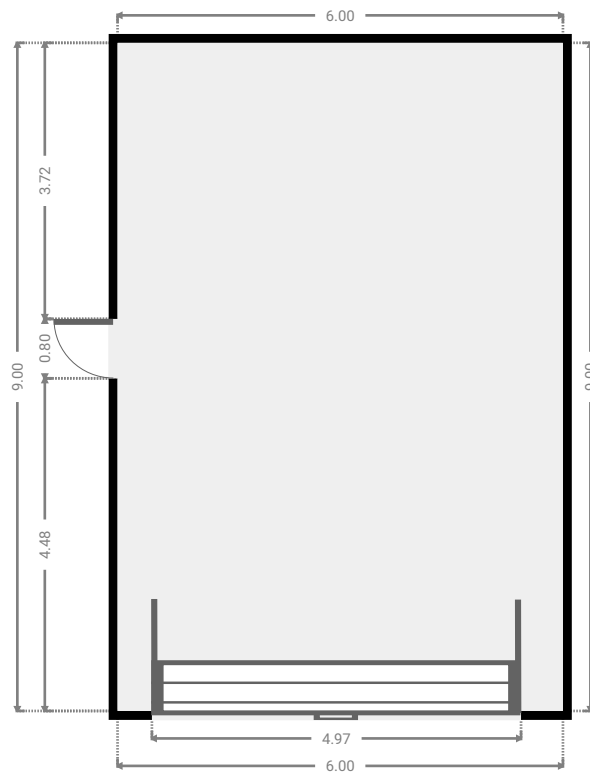

▼ 1st Floor

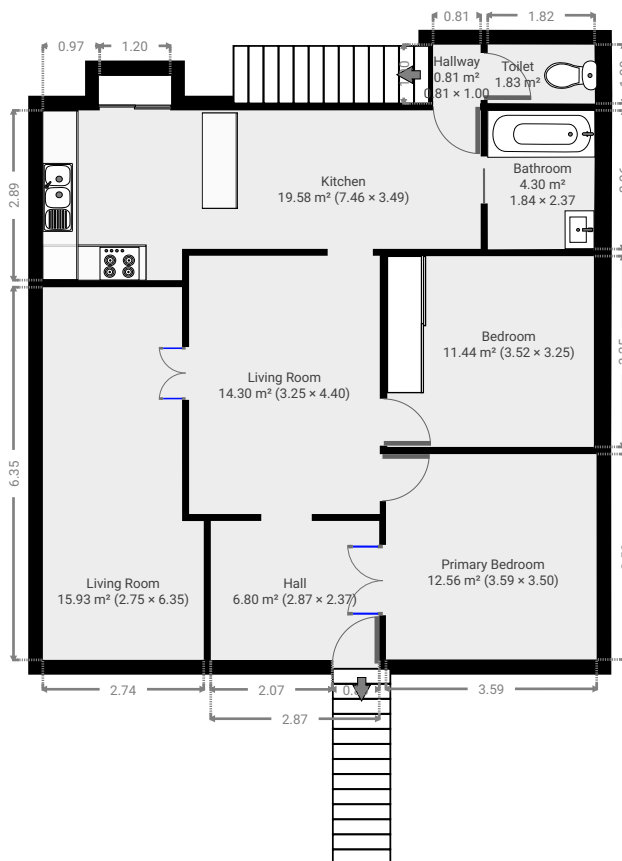

▼ Hall
1st Floor

WIDTH: 2.87 m • LENGTH: 2.37 m
AREA: 6.80 m² • PERIMETER: 10.48 m

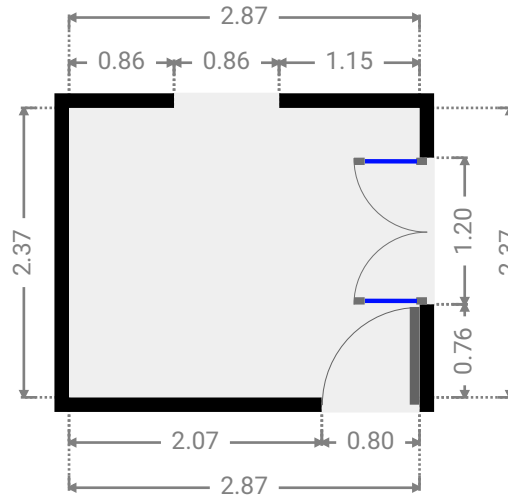
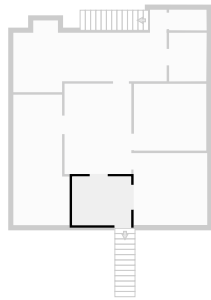

▼ Living Room
1st Floor

WIDTH: 3.25 m • LENGTH: 4.40 m
AREA: 14.30 m² • PERIMETER: 15.30 m

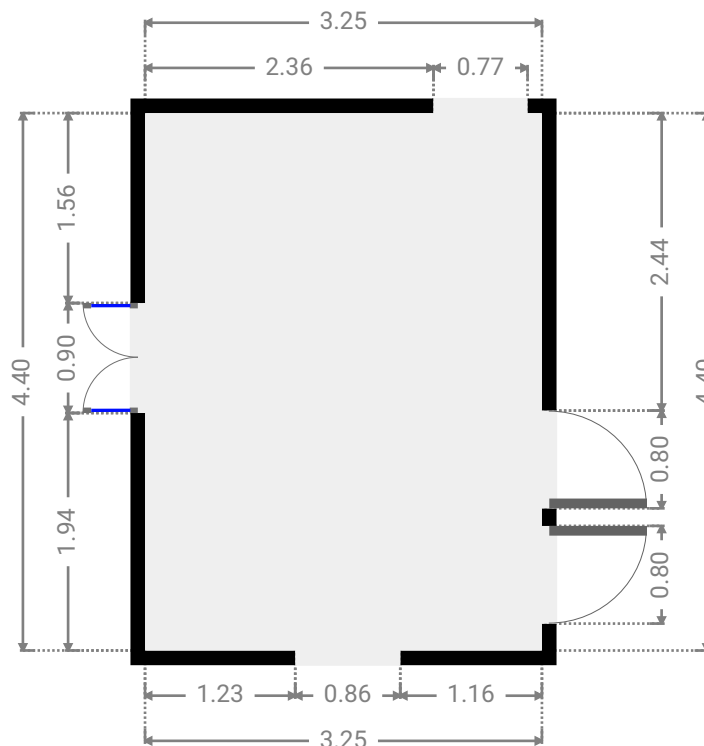
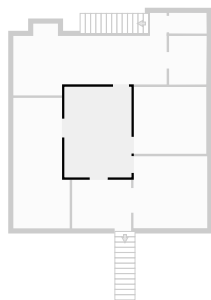

▼ **Primary Bedroom**
1st Floor

WIDTH: 3.59 m • LENGTH: 3.50 m
AREA: 12.56 m² • PERIMETER: 14.18 m

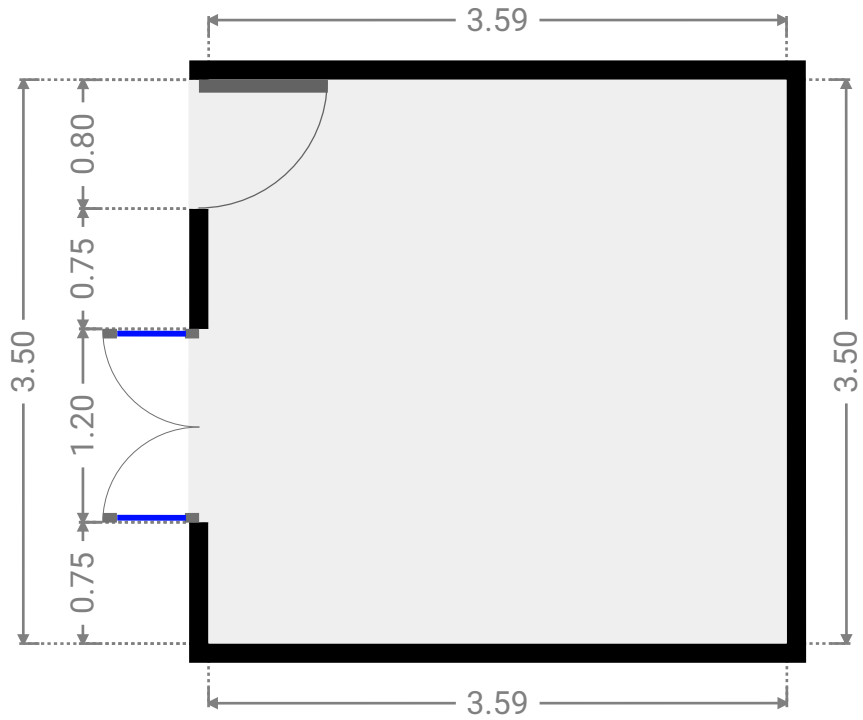
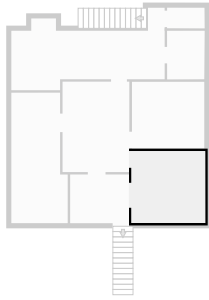

▼ **Bedroom**
1st Floor

WIDTH: 3.52 m • LENGTH: 3.25 m
AREA: 11.44 m² • PERIMETER: 13.54 m

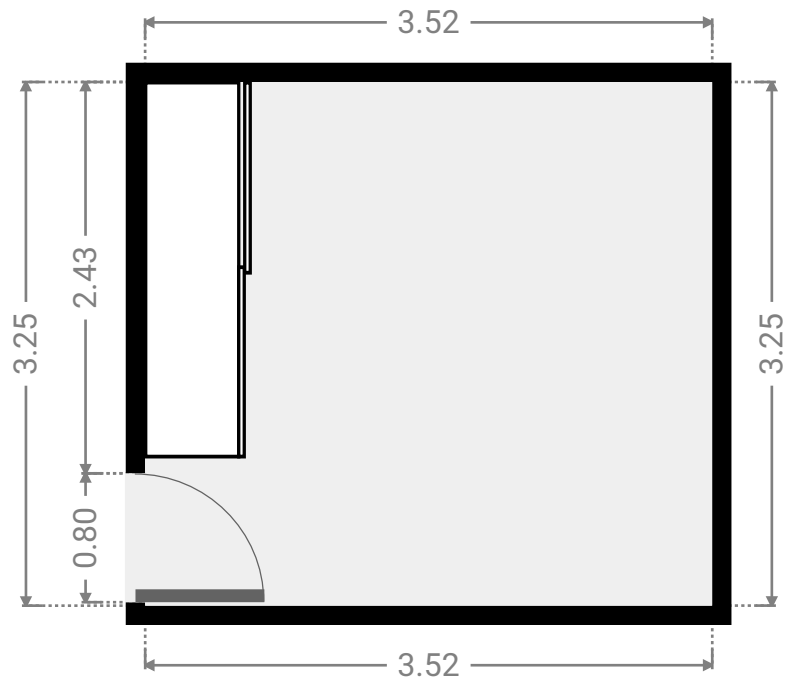
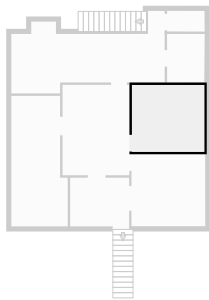

▼ Living Room
1st Floor

WIDTH: 2.75 m • LENGTH: 6.35 m
AREA: 15.93 m² • PERIMETER: 18.18 m

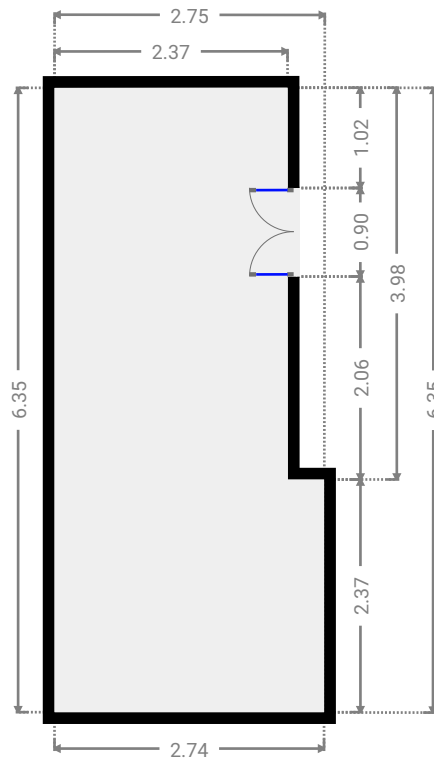
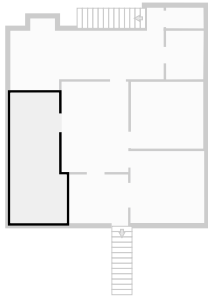

▼ Kitchen
1st Floor

WIDTH: 7.46 m • LENGTH: 3.49 m
AREA: 19.58 m² • PERIMETER: 21.90 m

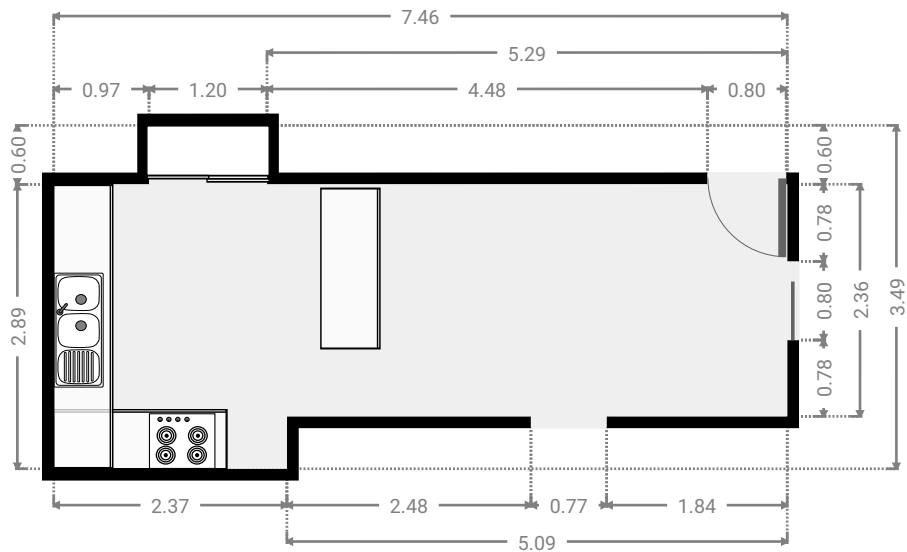
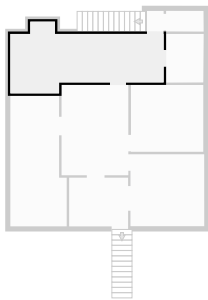

▼ **Bathroom**
1st Floor

WIDTH: 1.84 m • LENGTH: 2.37 m
AREA: 4.30 m² • PERIMETER: 8.36 m

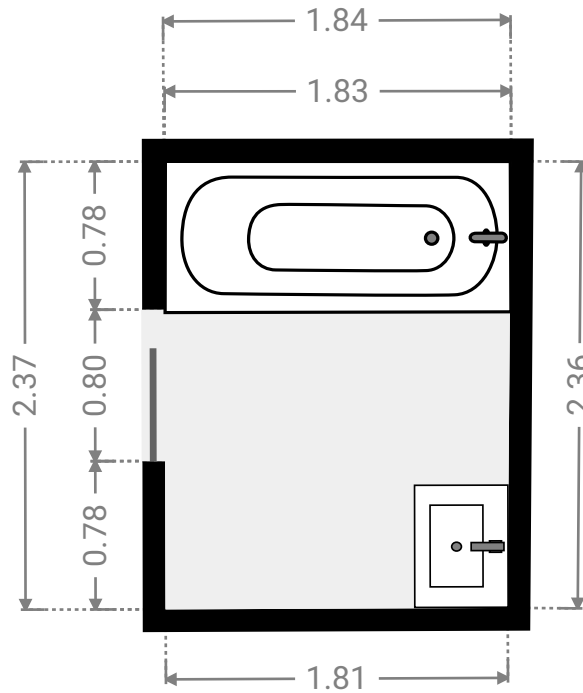
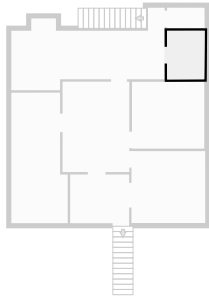

▼ **Toilet**
1st Floor

WIDTH: 1.83 m • LENGTH: 1.00 m
AREA: 1.83 m² • PERIMETER: 5.65 m

