

227 Farm Street

SUBMITTED BY

Ray White Rockhampton Casey
stockers@cqoz.com

CREATED ON

2022-10-12

Floors

2

▼ Ground Floor

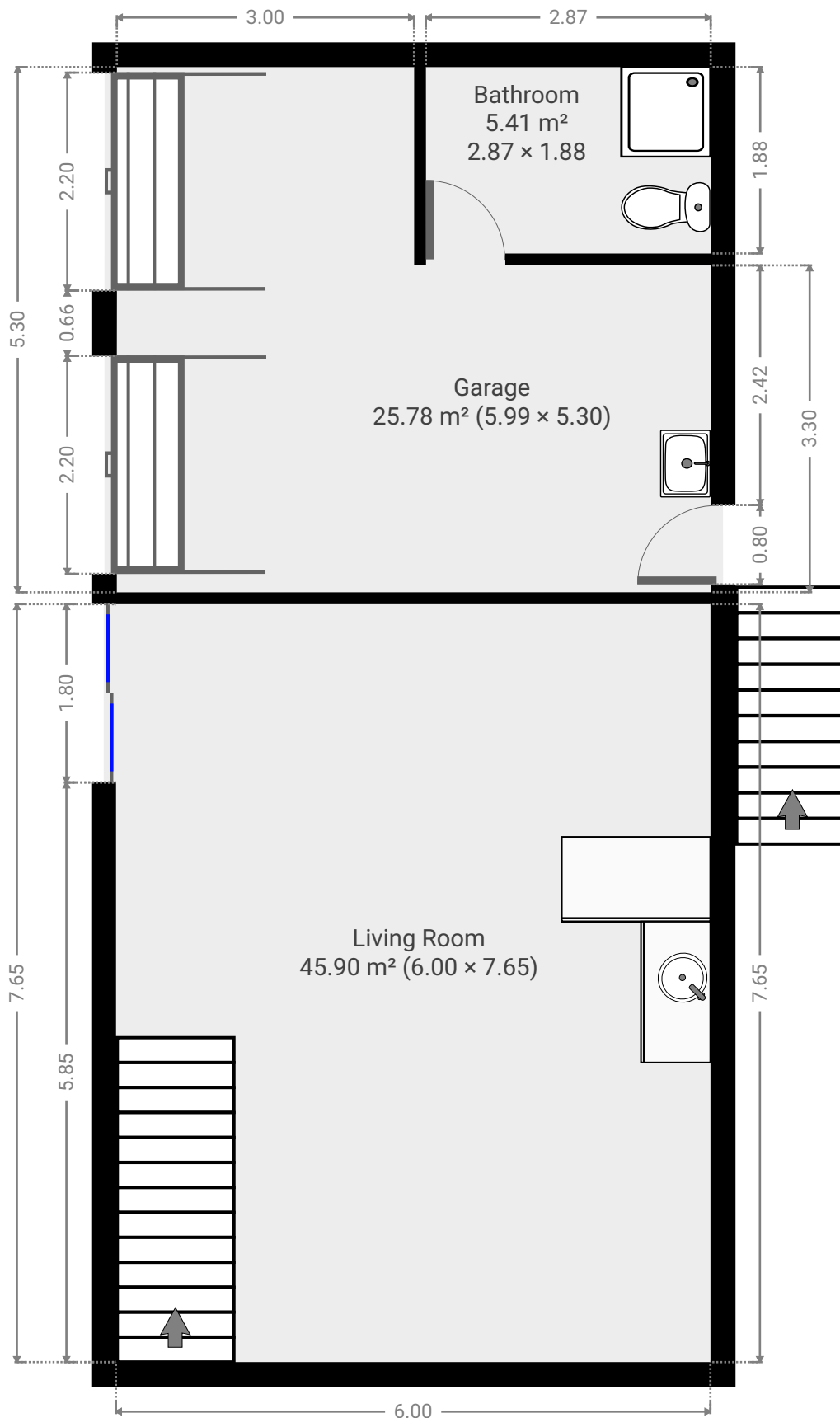

▼ **Bathroom**
Ground Floor

WIDTH: 1.88 m • LENGTH: 2.87 m
AREA: 5.41 m² • PERIMETER: 9.51 m

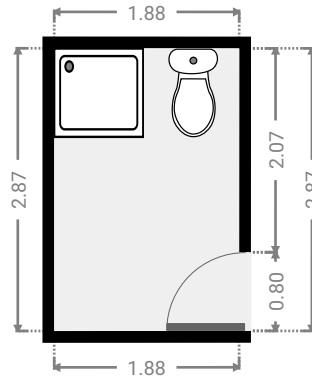

▼ **Garage**
Ground Floor

WIDTH: 5.30 m • LENGTH: 5.99 m
AREA: 25.78 m² • PERIMETER: 22.58 m

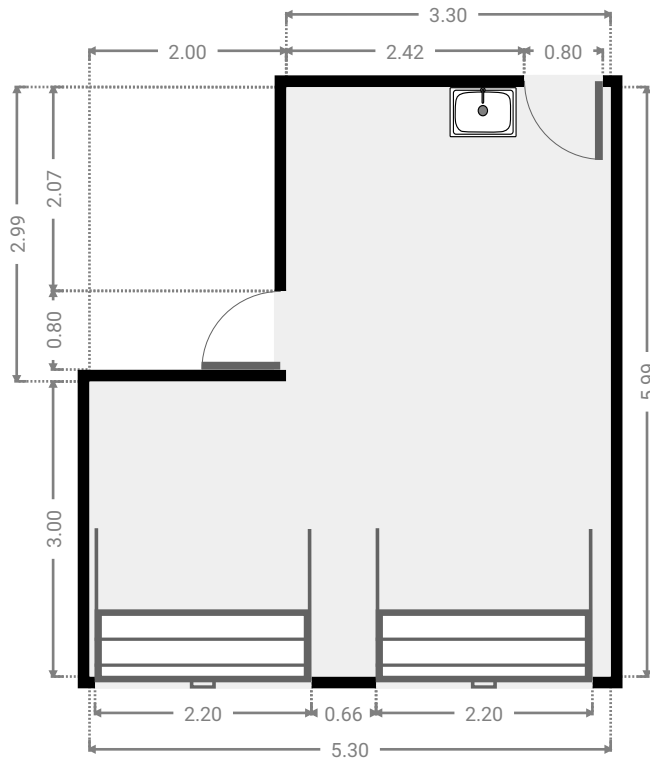
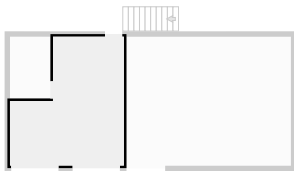

▼ **Living Room**
Ground Floor

WIDTH: 7.65 m • LENGTH: 6.00 m
AREA: 45.90 m² • PERIMETER: 27.30 m

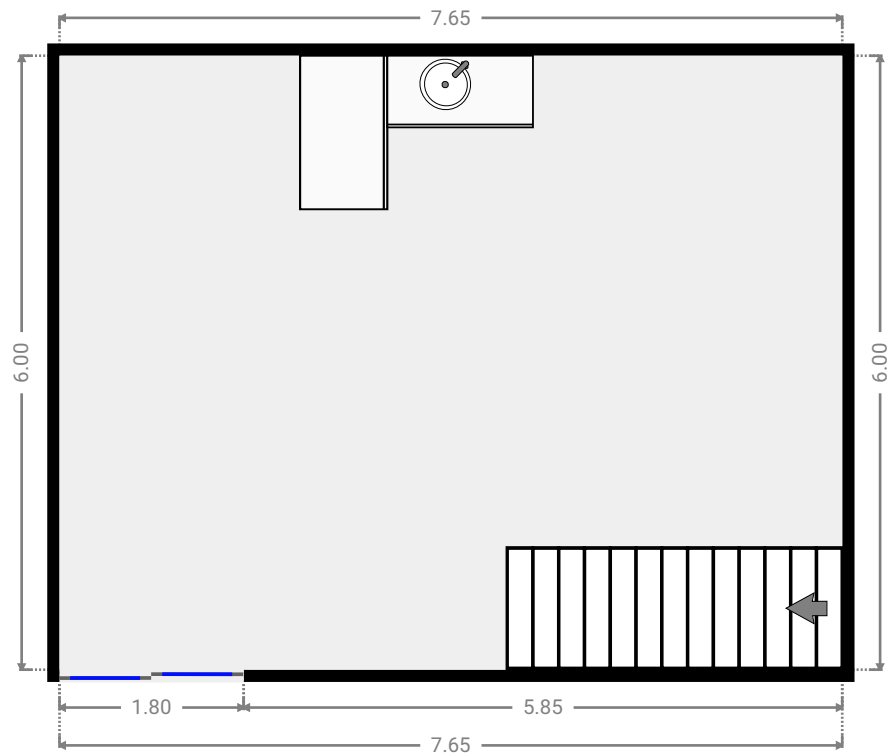
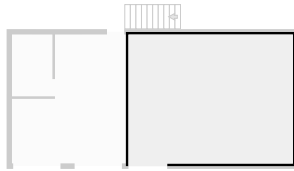

▼ 1st Floor

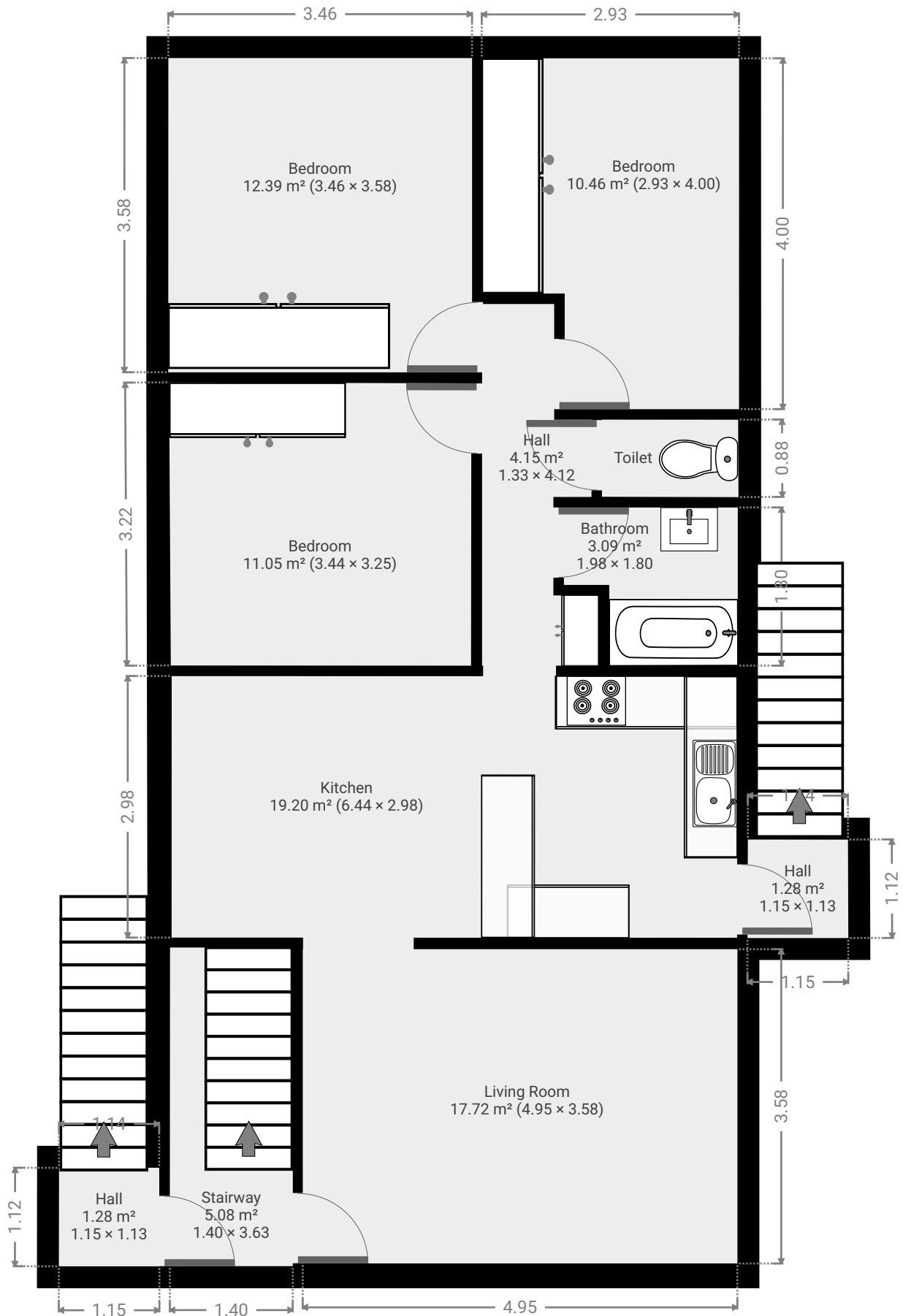

▼ **Bathroom**
1st Floor

WIDTH: 1.80 m • LENGTH: 1.98 m
AREA: 3.09 m² • PERIMETER: 7.56 m

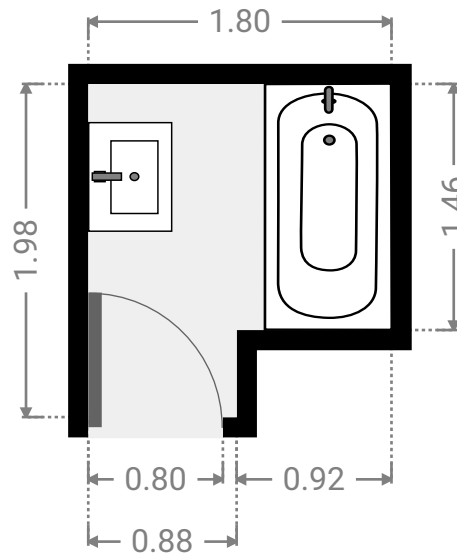
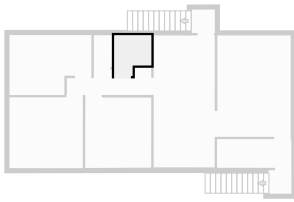

▼ **Bedroom**
1st Floor

WIDTH: 4.00 m • LENGTH: 2.93 m
AREA: 10.46 m² • PERIMETER: 13.85 m

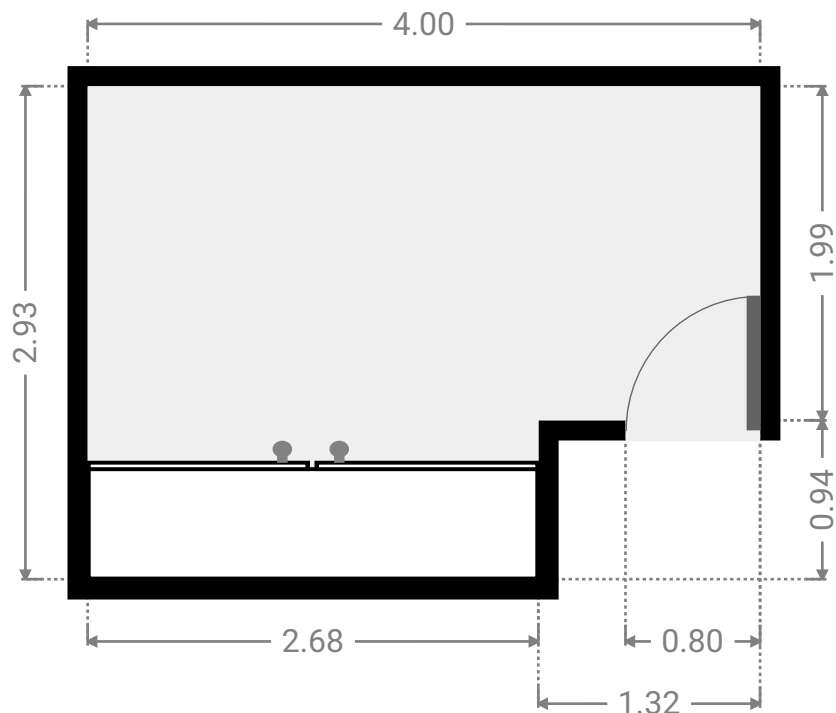
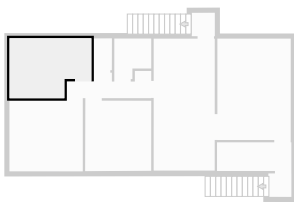

▼ **Bedroom**
1st Floor

WIDTH: 3.58 m • LENGTH: 3.46 m
AREA: 12.39 m² • PERIMETER: 14.08 m

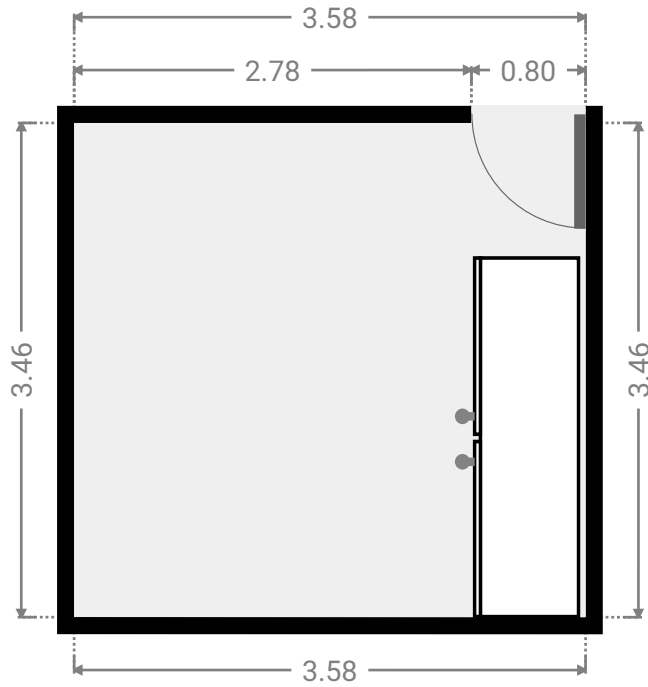
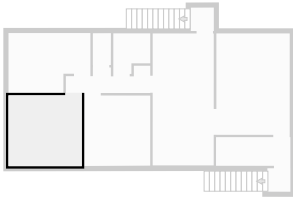

▼ **Bedroom**
1st Floor

WIDTH: 3.25 m • LENGTH: 3.44 m
AREA: 11.05 m² • PERIMETER: 13.30 m

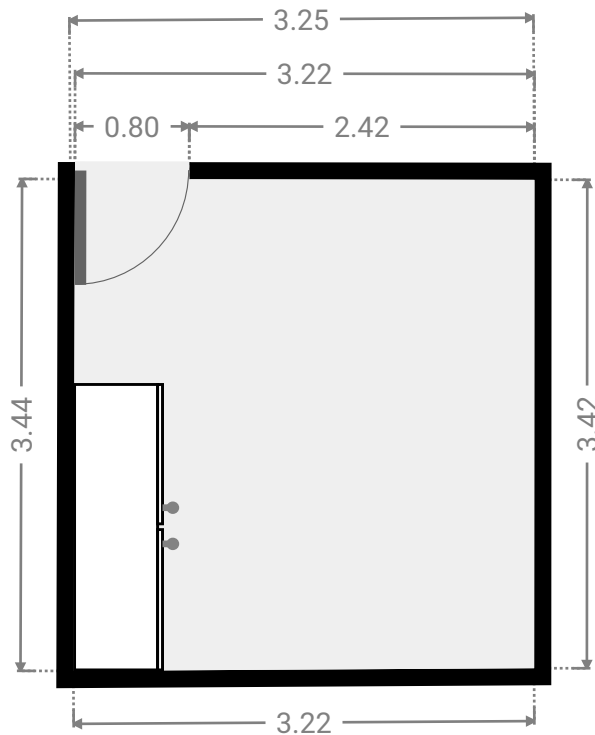
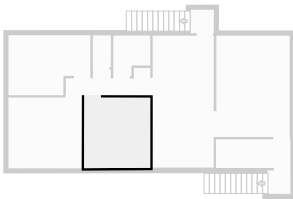

▼ **Hall**
1st Floor

WIDTH: 4.12 m • LENGTH: 1.33 m
AREA: 4.15 m² • PERIMETER: 11.77 m

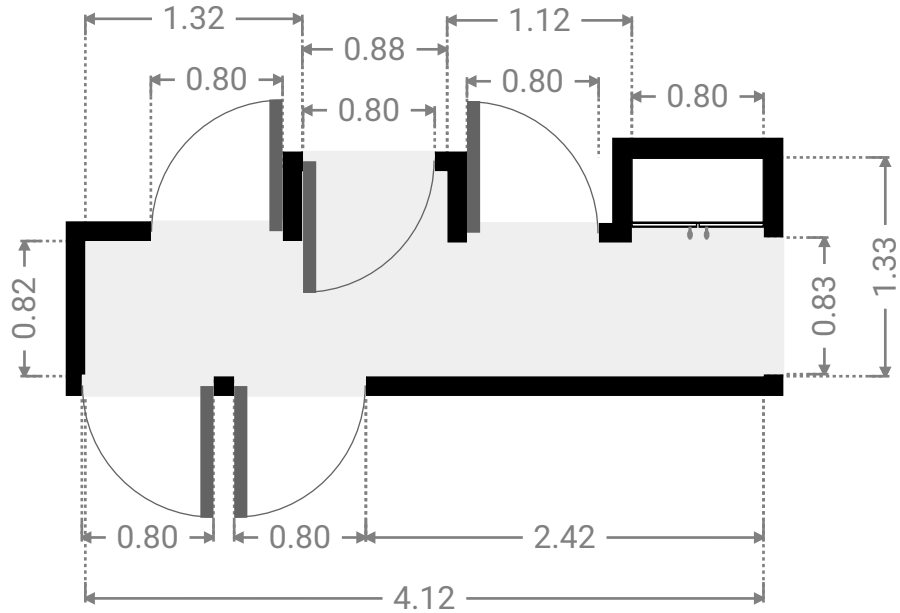
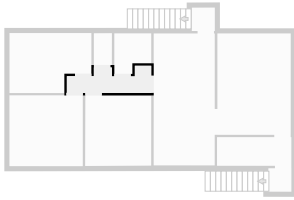

▼ **Hall**
1st Floor

WIDTH: 1.13 m • LENGTH: 1.15 m
AREA: 1.28 m² • PERIMETER: 4.53 m

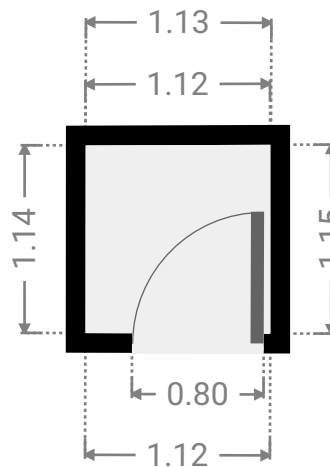
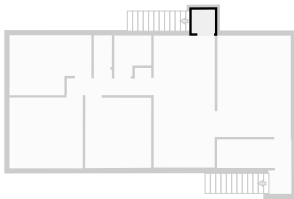

▼ **Hall**
1st Floor

WIDTH: 1.13 m • LENGTH: 1.15 m
AREA: 1.28 m² • PERIMETER: 4.53 m

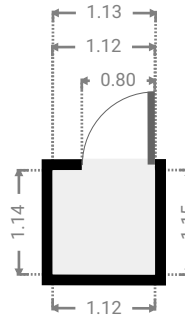
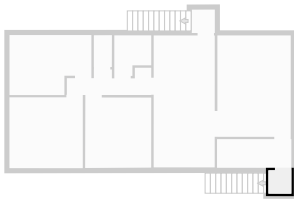

▼ **Kitchen**
1st Floor

WIDTH: 2.98 m • LENGTH: 6.44 m
AREA: 19.20 m² • PERIMETER: 18.84 m

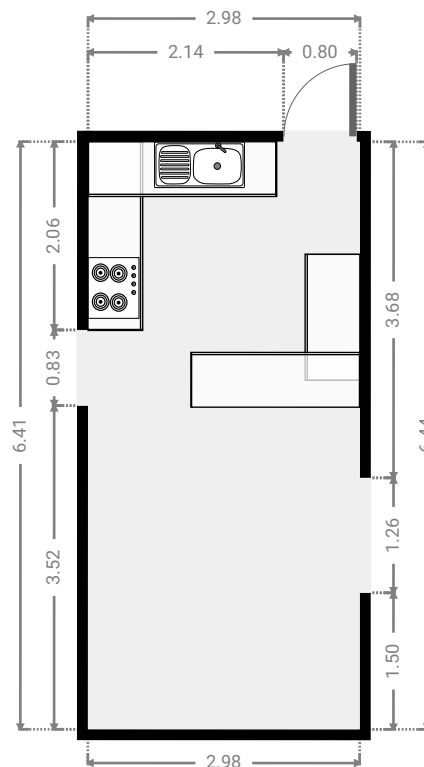
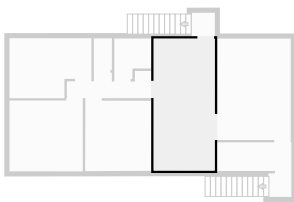

▼ **Living Room**
1st Floor

WIDTH: 3.58 m • LENGTH: 4.95 m
AREA: 17.72 m² • PERIMETER: 17.06 m

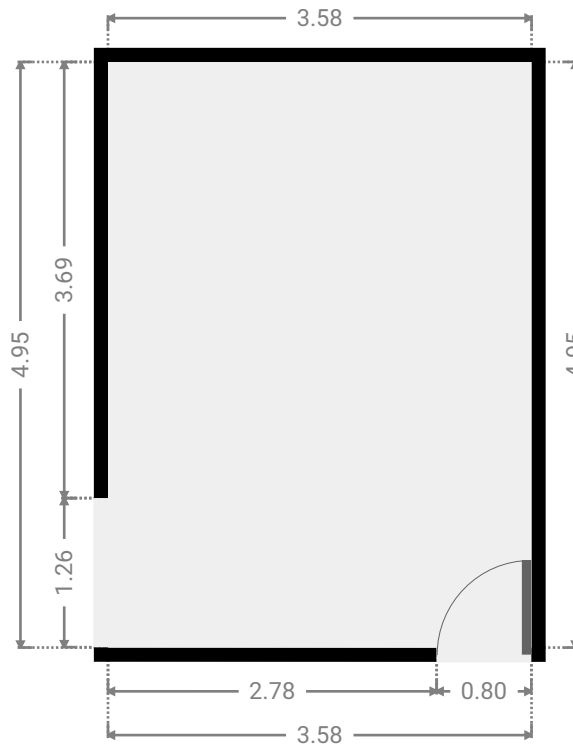
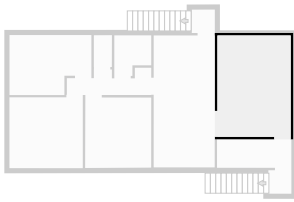

▼ **Stairway**
1st Floor

WIDTH: 3.63 m • LENGTH: 1.40 m
AREA: 5.08 m² • PERIMETER: 10.06 m

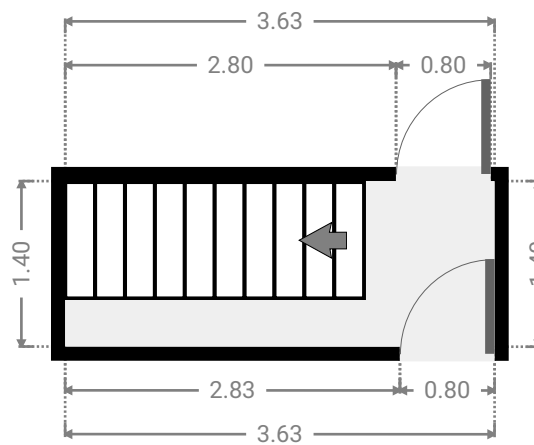
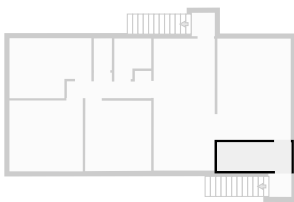

▼ Toilet
1st Floor

WIDTH: 0.88 m • LENGTH: 1.55 m
AREA: 1.37 m² • PERIMETER: 4.87 m

