

220 Kerrigan Street

SUBMITTED BY

Ray White Rockhampton Casey
stockers@cqoz.com

CREATED ON

2022-06-20

Floors

2

▼ Ground Floor



▼ **Bathroom**
Ground Floor

WIDTH: 2.95 m • LENGTH: 2.12 m
AREA: 6.26 m² • PERIMETER: 10.14 m

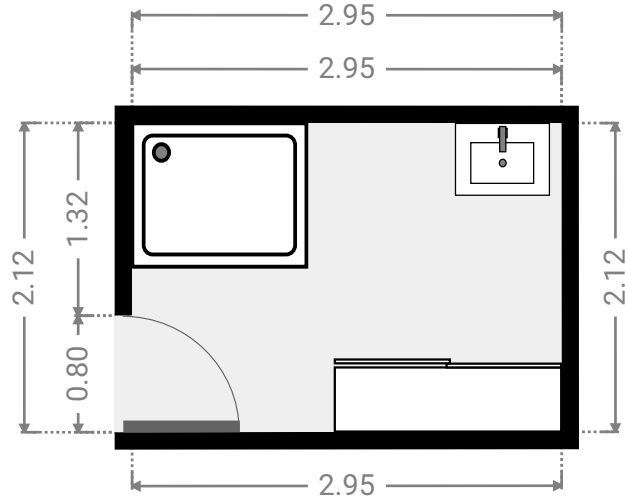
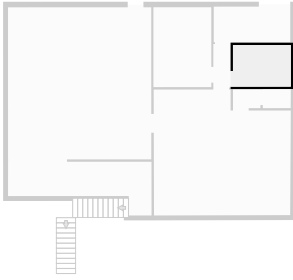

▼ **Bedroom**
Ground Floor

WIDTH: 2.95 m • LENGTH: 4.07 m
AREA: 12.01 m² • PERIMETER: 14.04 m

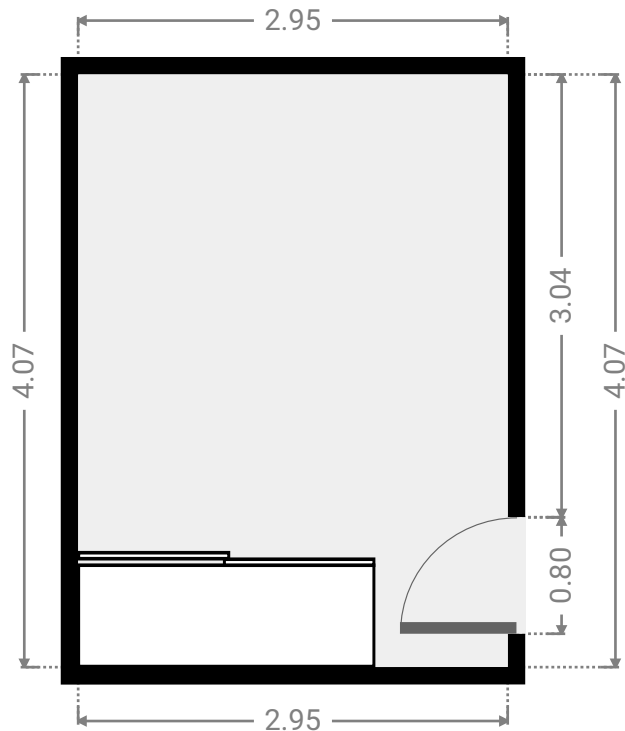
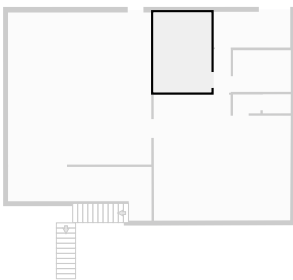

▼ **Garage**
Ground Floor

WIDTH: 7.30 m • LENGTH: 7.75 m
AREA: 56.57 m² • PERIMETER: 30.10 m

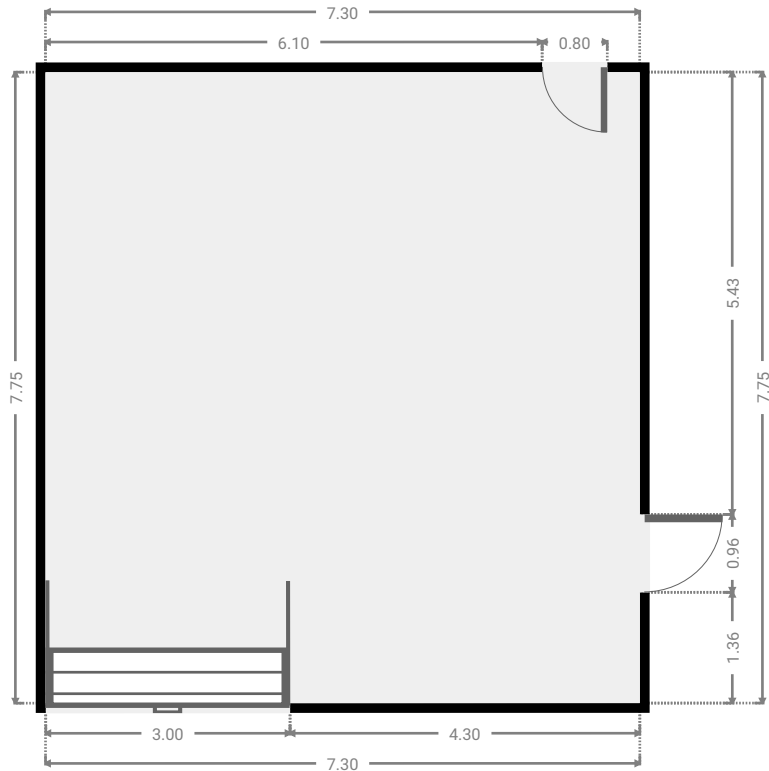
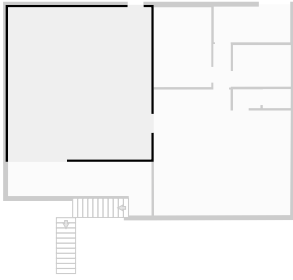

▼ **Hall**
Ground Floor

WIDTH: 1.40 m • LENGTH: 0.95 m
AREA: 1.34 m² • PERIMETER: 4.72 m

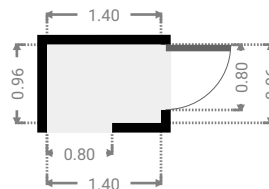
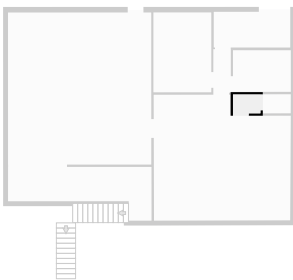

▼ Hall
Ground Floor

WIDTH: 0.89 m • LENGTH: 2.22 m
AREA: 1.97 m² • PERIMETER: 6.22 m

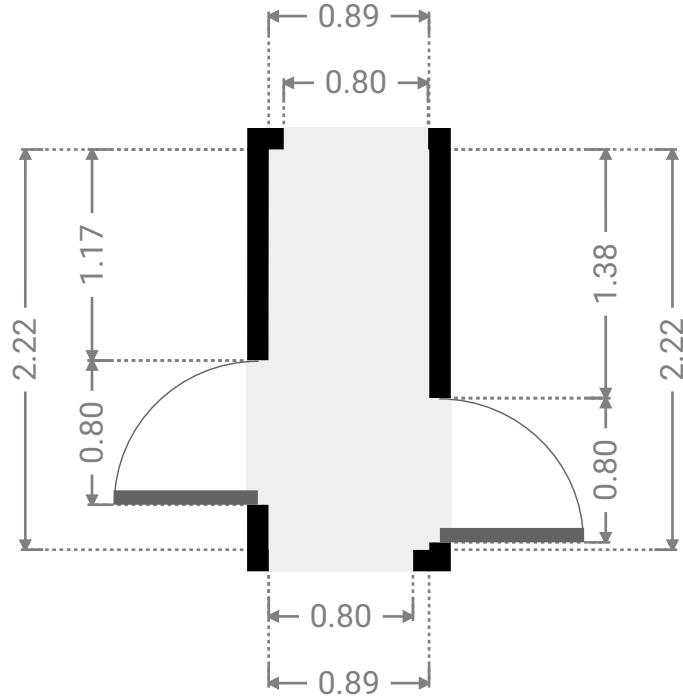

▼ Laundry Room
Ground Floor

WIDTH: 3.90 m • LENGTH: 1.82 m
AREA: 7.09 m² • PERIMETER: 11.44 m

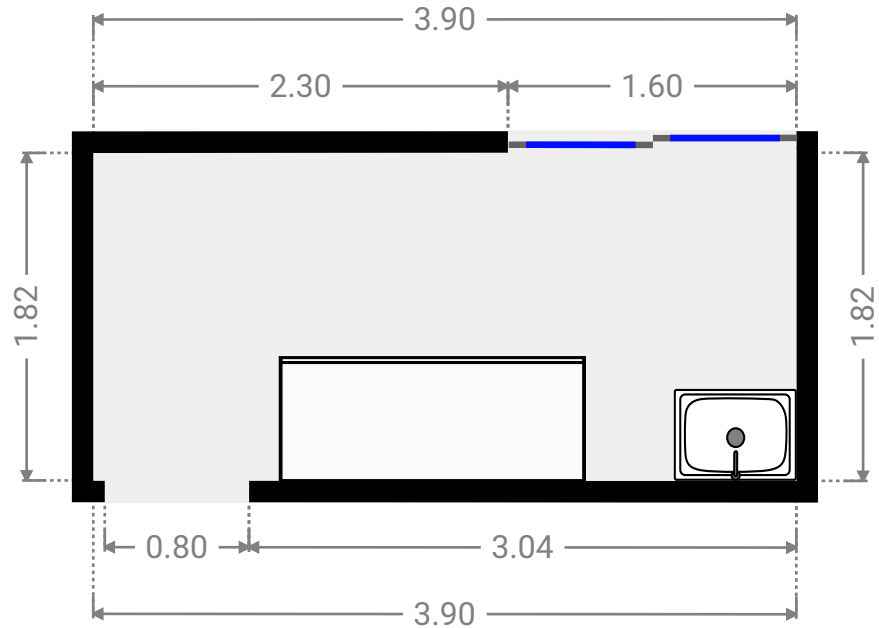
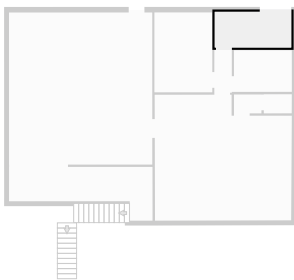

▼ Living Room
Ground Floor

WIDTH: 6.99 m • LENGTH: 6.40 m
AREA: 41.37 m² • PERIMETER: 26.75 m

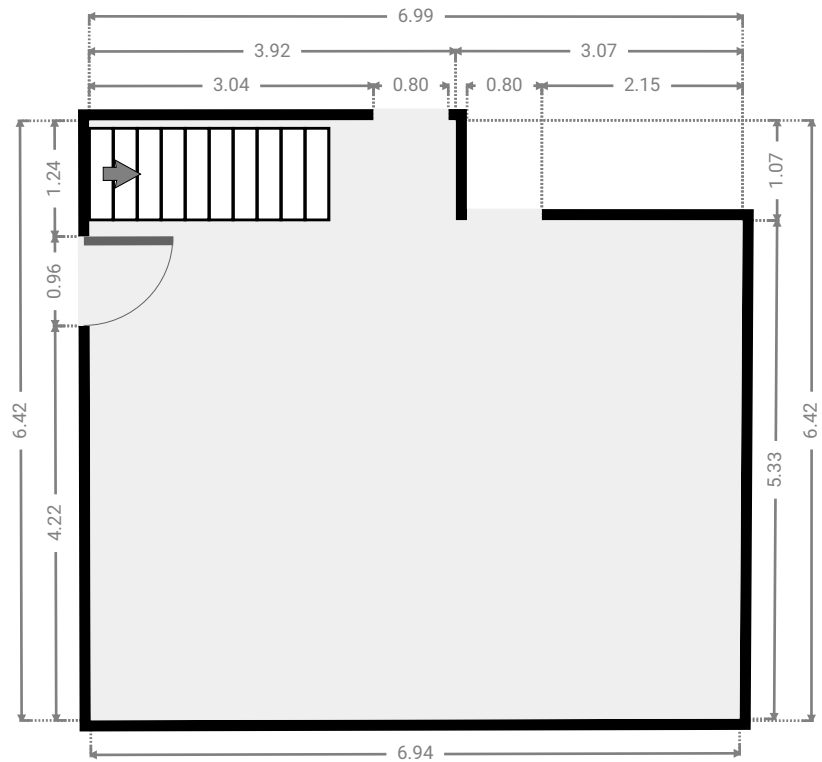
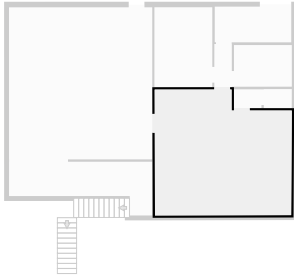

▼ Other
Ground Floor

WIDTH: 7.31 m • LENGTH: 2.74 m
AREA: 13.93 m² • PERIMETER: 20.10 m

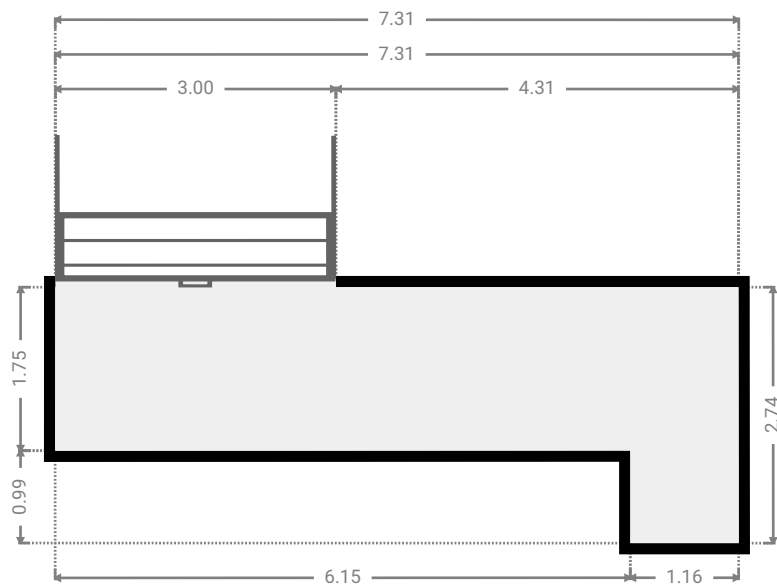
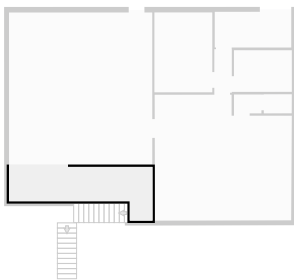

▼ Toilet
Ground Floor

WIDTH: 1.44 m • LENGTH: 0.96 m
AREA: 1.38 m² • PERIMETER: 4.79 m

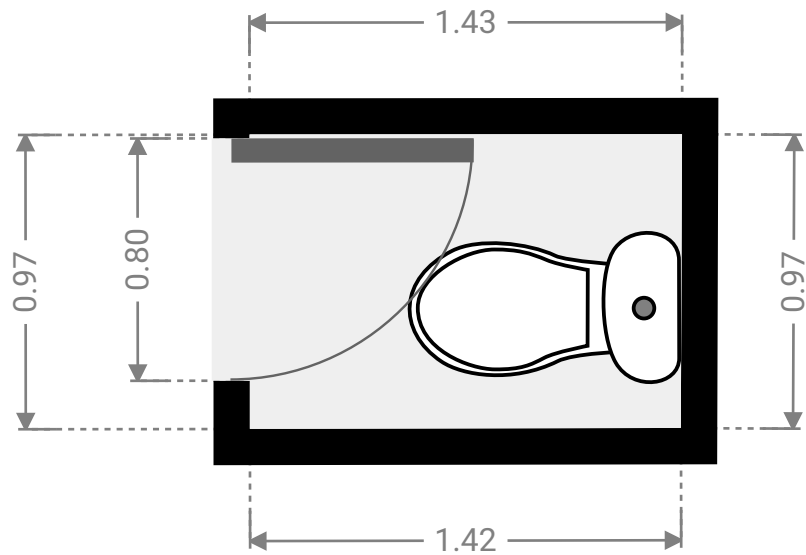
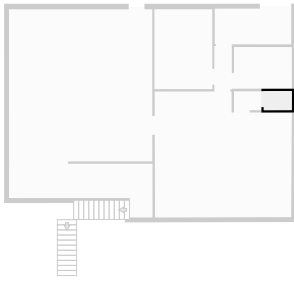

▼ 1st Floor

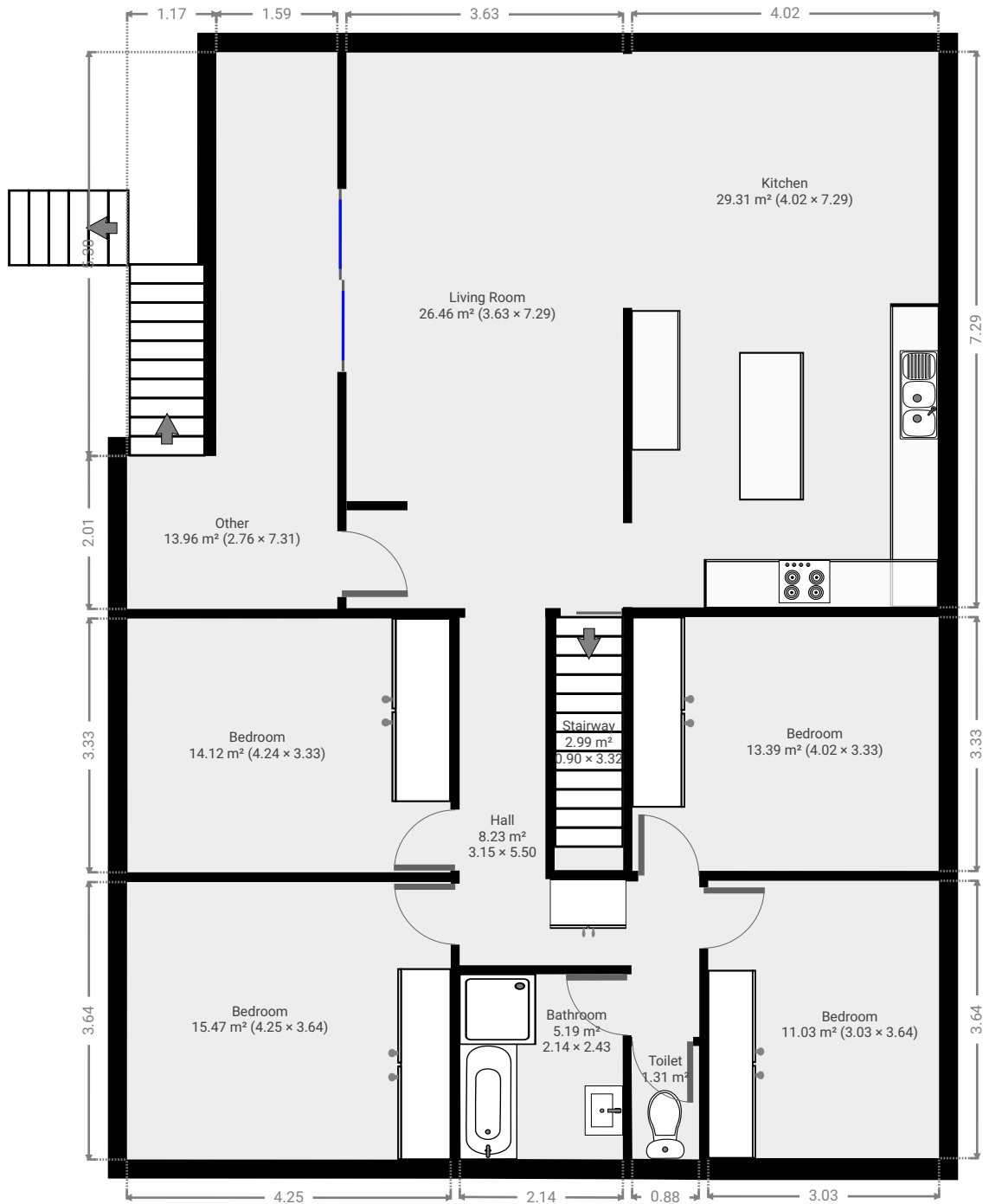

▼ **Bathroom**
1st Floor

WIDTH: 2.43 m • LENGTH: 2.14 m
AREA: 5.19 m² • PERIMETER: 9.13 m

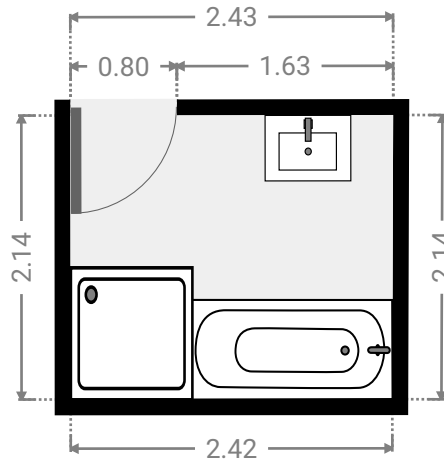
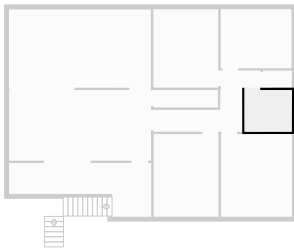

▼ **Bedroom**
1st Floor

WIDTH: 3.33 m • LENGTH: 4.24 m
AREA: 14.12 m² • PERIMETER: 15.14 m

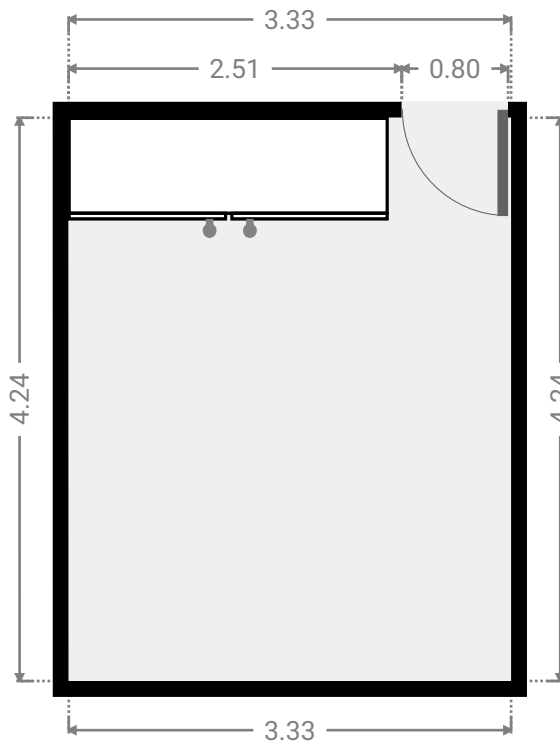
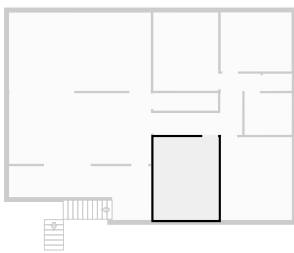

▼ **Bedroom**
1st Floor

WIDTH: 3.64 m • LENGTH: 4.25 m
AREA: 15.47 m² • PERIMETER: 15.78 m

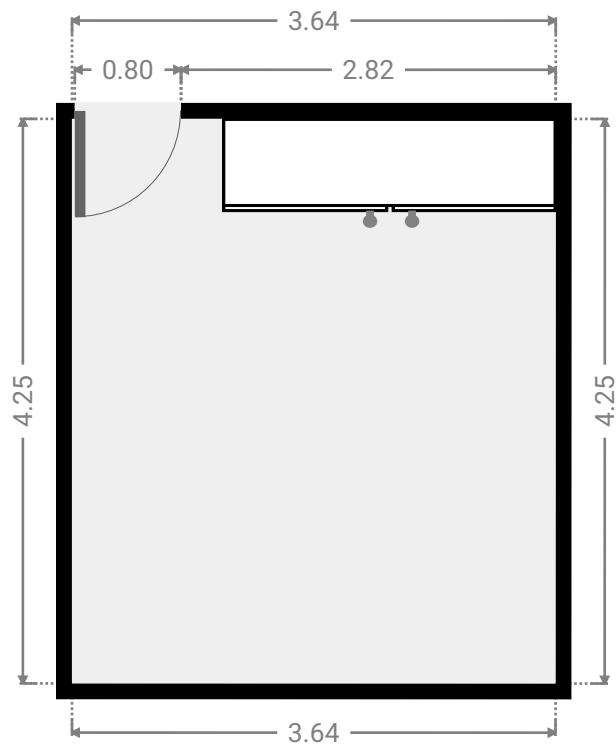
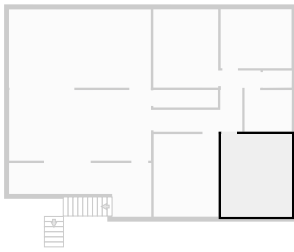

▼ **Bedroom**
1st Floor

WIDTH: 3.33 m • LENGTH: 4.02 m
AREA: 13.39 m² • PERIMETER: 14.70 m

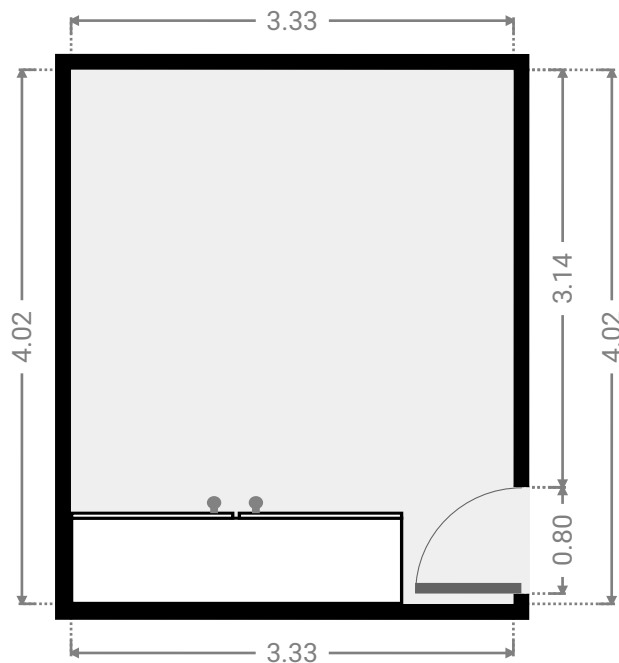
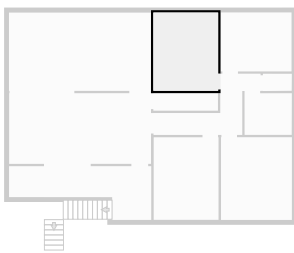

▼ **Bedroom**
1st Floor

WIDTH: 3.64 m • LENGTH: 3.03 m
AREA: 11.03 m² • PERIMETER: 13.34 m

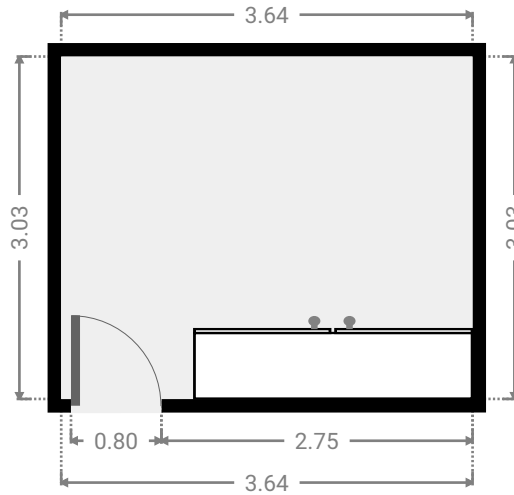
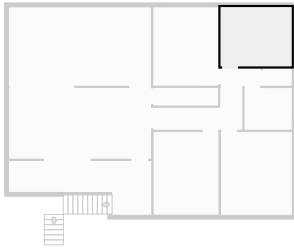

▼ **Hall**
1st Floor

WIDTH: 5.50 m • LENGTH: 3.15 m
AREA: 8.23 m² • PERIMETER: 17.29 m

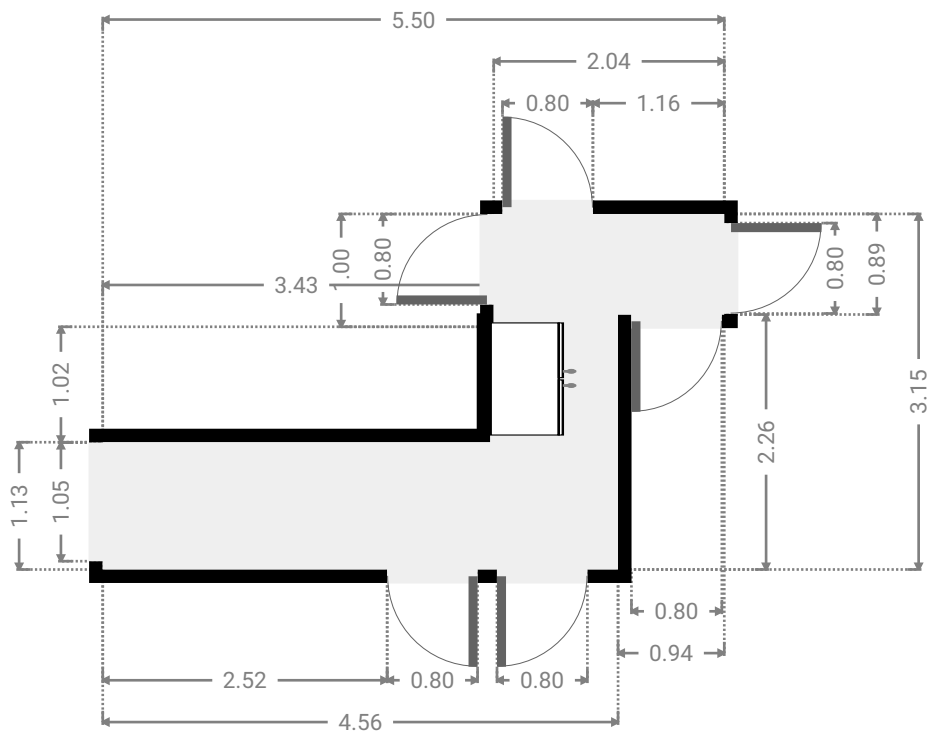
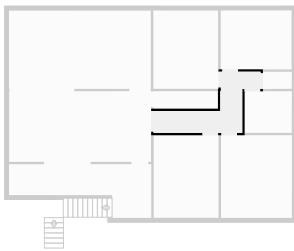

▼ **Kitchen**
1st Floor

WIDTH: 7.29 m • LENGTH: 4.02 m
AREA: 29.31 m² • PERIMETER: 22.62 m

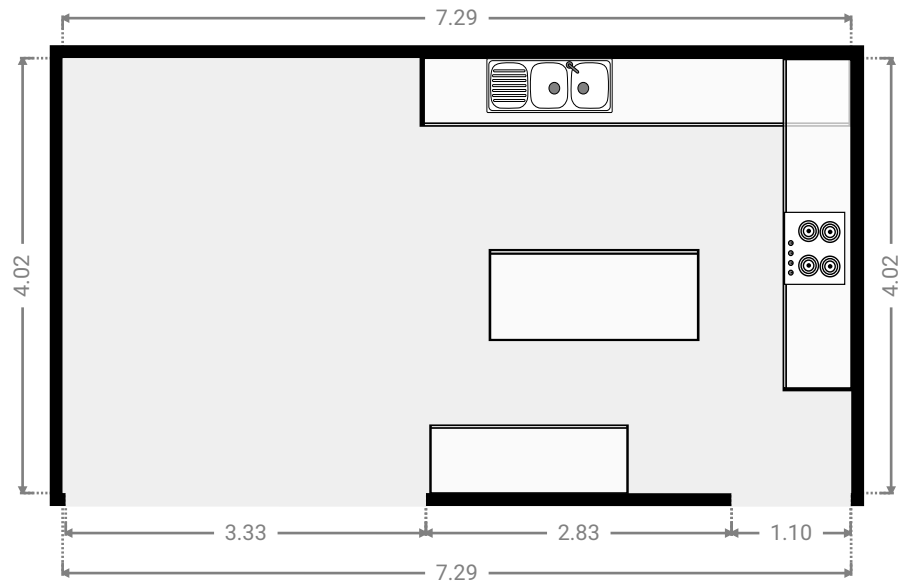
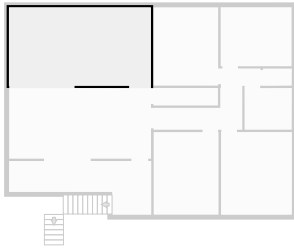

▼ **Living Room**
1st Floor

WIDTH: 7.29 m • LENGTH: 3.63 m
AREA: 26.46 m² • PERIMETER: 21.84 m

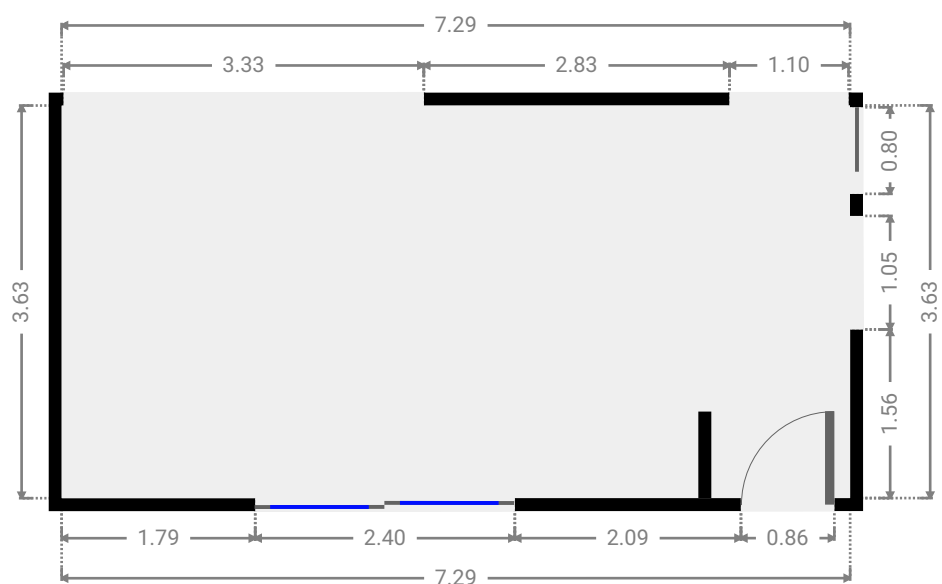
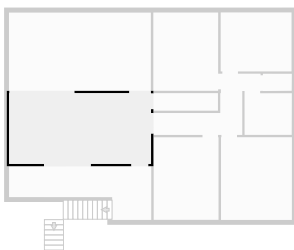

▼ Other
1st Floor

WIDTH: 7.31 m • LENGTH: 2.76 m
AREA: 13.96 m² • PERIMETER: 20.13 m

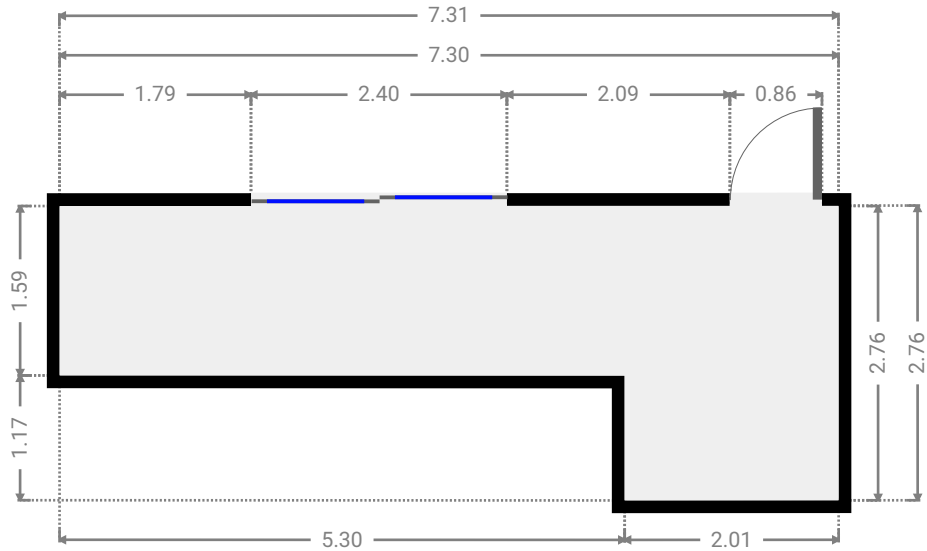
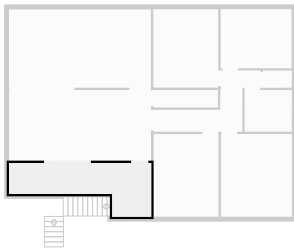

▼ Stairway
1st Floor

WIDTH: 3.32 m • LENGTH: 0.90 m
AREA: 2.99 m² • PERIMETER: 8.44 m

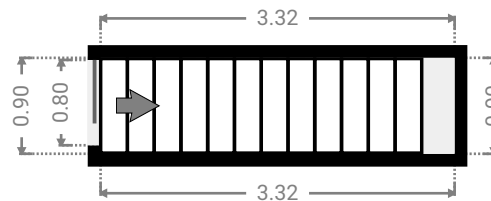
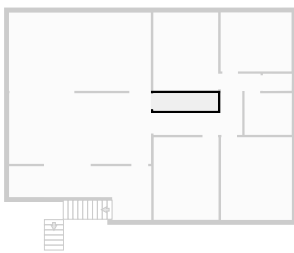

▼ Toilet
1st Floor

WIDTH: 1.49 m • LENGTH: 0.89 m
AREA: 1.31 m² • PERIMETER: 4.73 m

