

# 212 FARM street

**SUBMITTED BY**  
Ray White Rockhampton Casey  
stockers@cqoz.com

---

**CREATED ON**  
2022-05-09

---

**Floors**  
2

---

▼ Basement

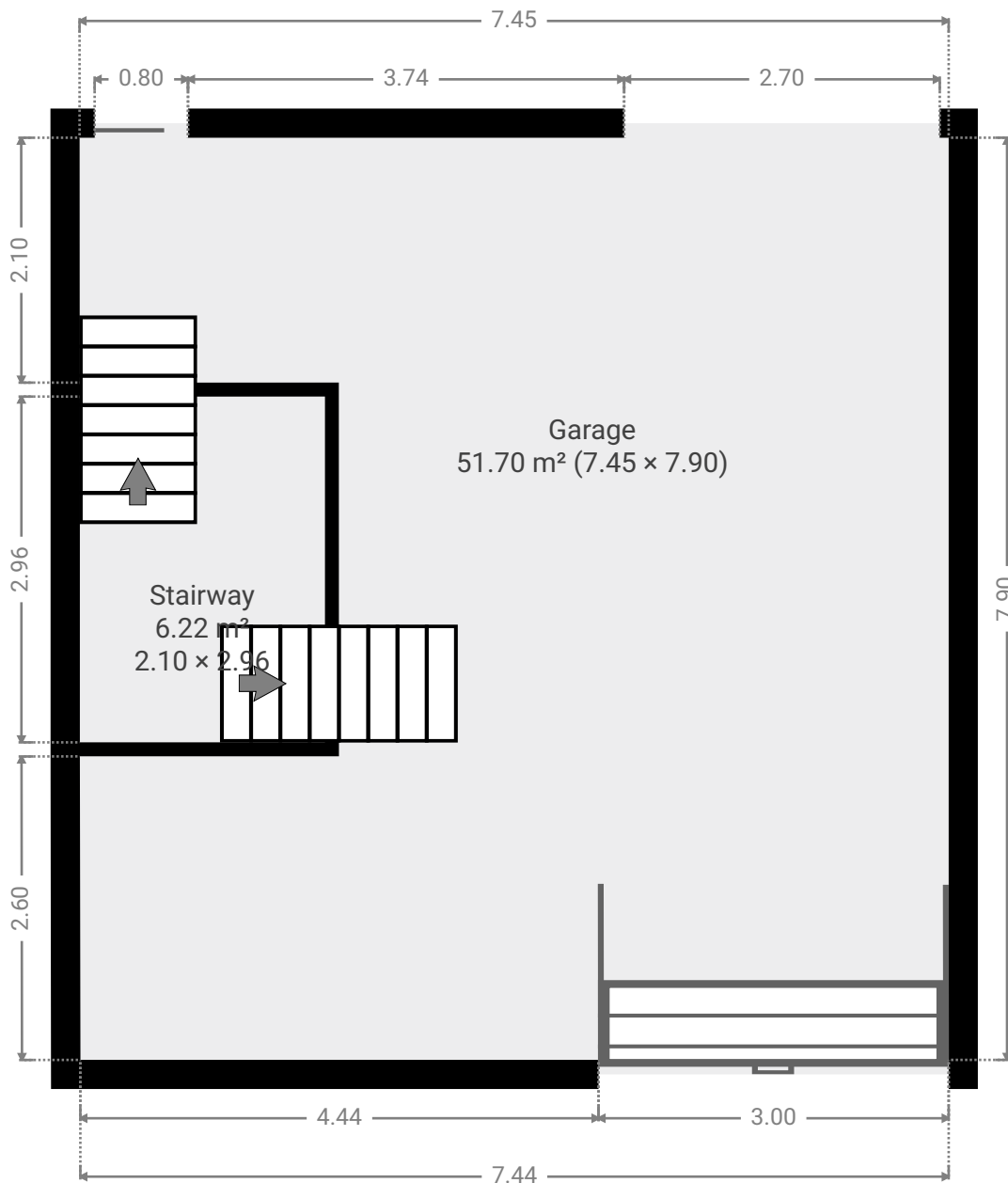

▼ **Garage**  
Basement

WIDTH: 7.45 m • LENGTH: 7.90 m  
AREA: 51.70 m<sup>2</sup> • PERIMETER: 35.13 m

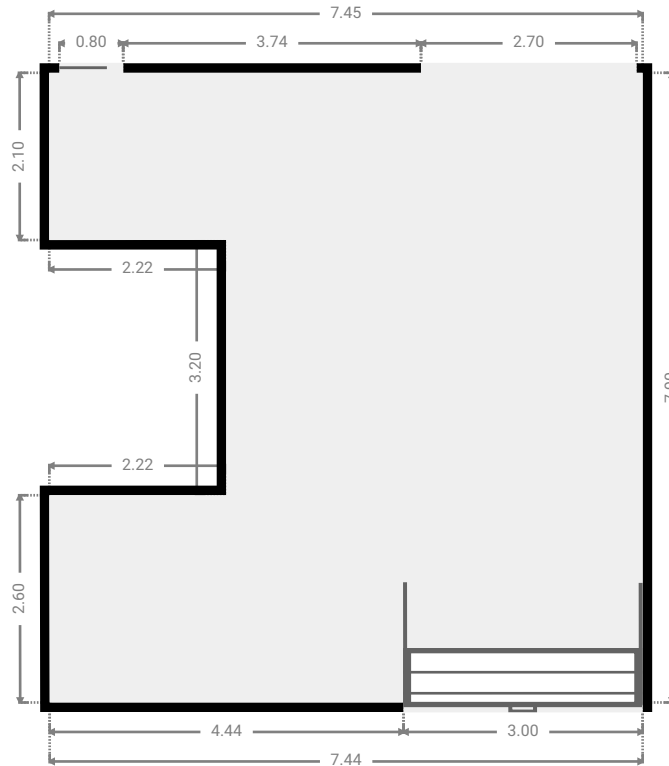
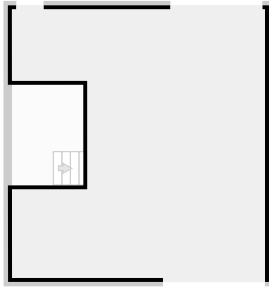

▼ **Stairway**  
Basement

WIDTH: 2.10 m • LENGTH: 2.96 m  
AREA: 6.22 m<sup>2</sup> • PERIMETER: 10.13 m

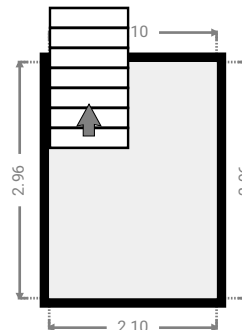
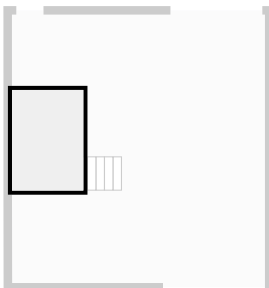

▼ Ground Floor

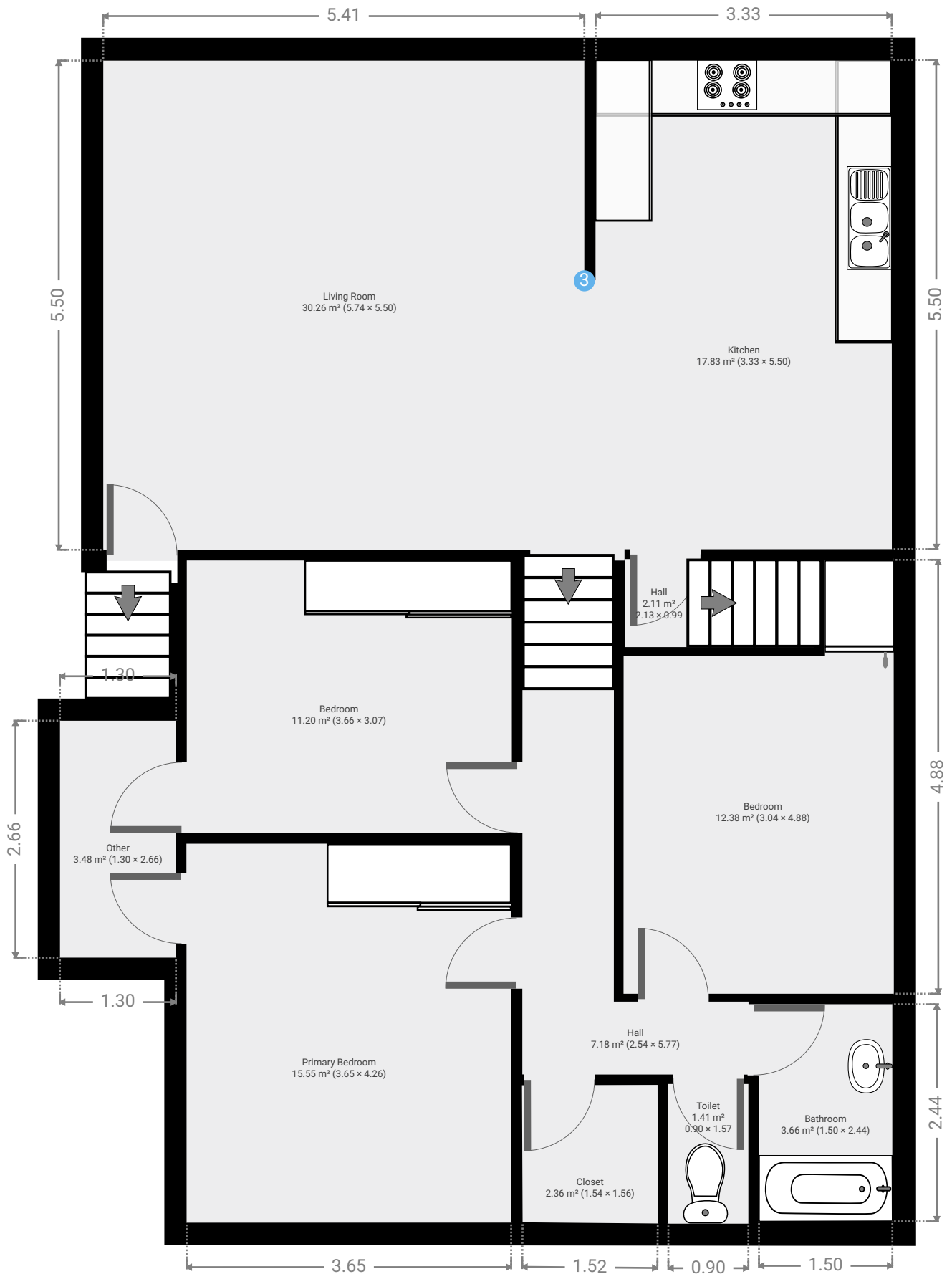

THIS FLOORPLAN IS PROVIDED WITHOUT WARRANTY OF ANY KIND. SENSOPIA DISCLAIMS ANY WARRANTY INCLUDING, WITHOUT LIMITATION, SATISFACTORY QUALITY OR ACCURACY OF DIMENSIONS.

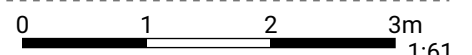

▼ **Living Room**  
Ground Floor

WIDTH: 5.50 m • LENGTH: 5.74 m  
AREA: 30.26 m<sup>2</sup> • PERIMETER: 22.17 m

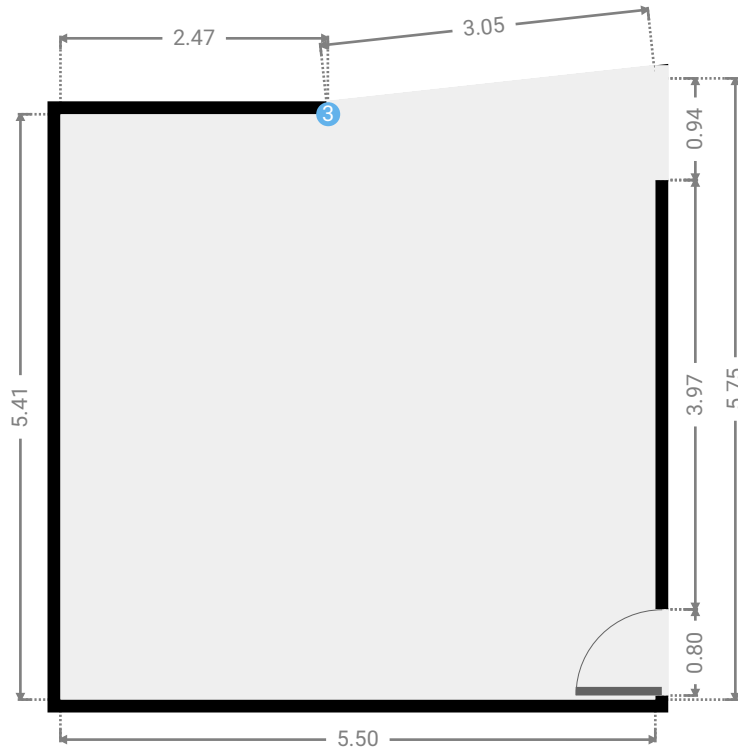
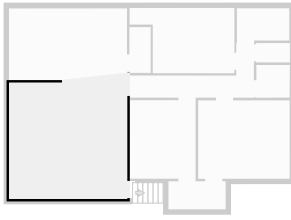

▼ **Living Room/Ground Floor**

**3 OPENING**

Height  
0.00 m



▼ **Kitchen**  
Ground Floor

WIDTH: 5.50 m • LENGTH: 3.33 m  
AREA: 17.83 m<sup>2</sup> • PERIMETER: 17.36 m

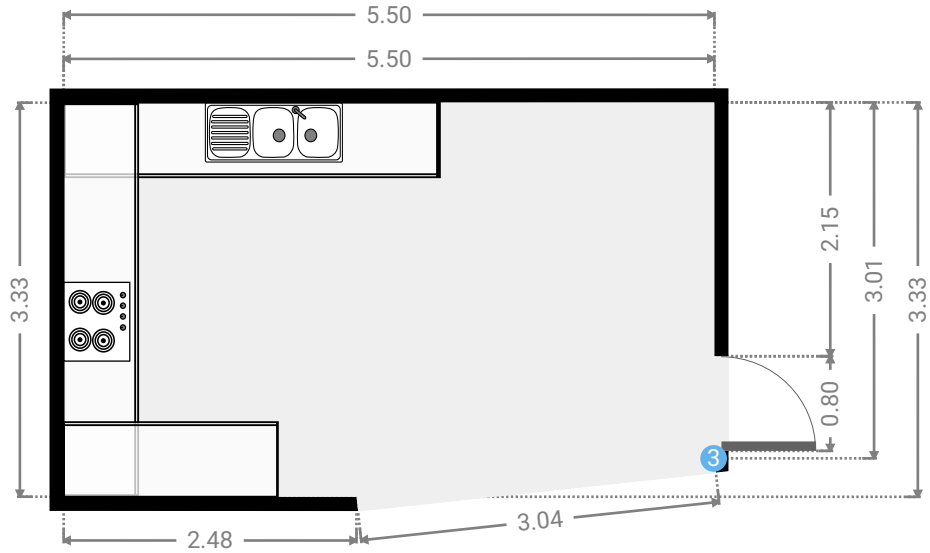
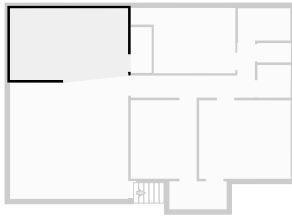

▼ **Hall**  
Ground Floor

WIDTH: 0.99 m • LENGTH: 2.13 m  
AREA: 2.11 m<sup>2</sup> • PERIMETER: 6.24 m

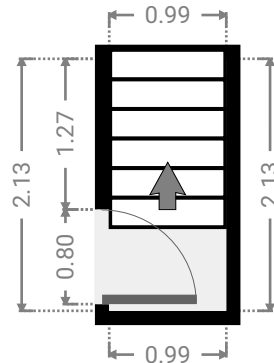
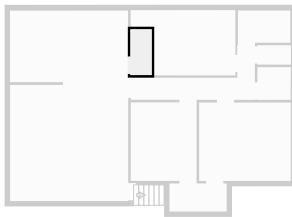

▼ **Hall**  
Ground Floor

WIDTH: 5.77 m • LENGTH: 2.54 m  
AREA: 7.18 m<sup>2</sup> • PERIMETER: 16.63 m

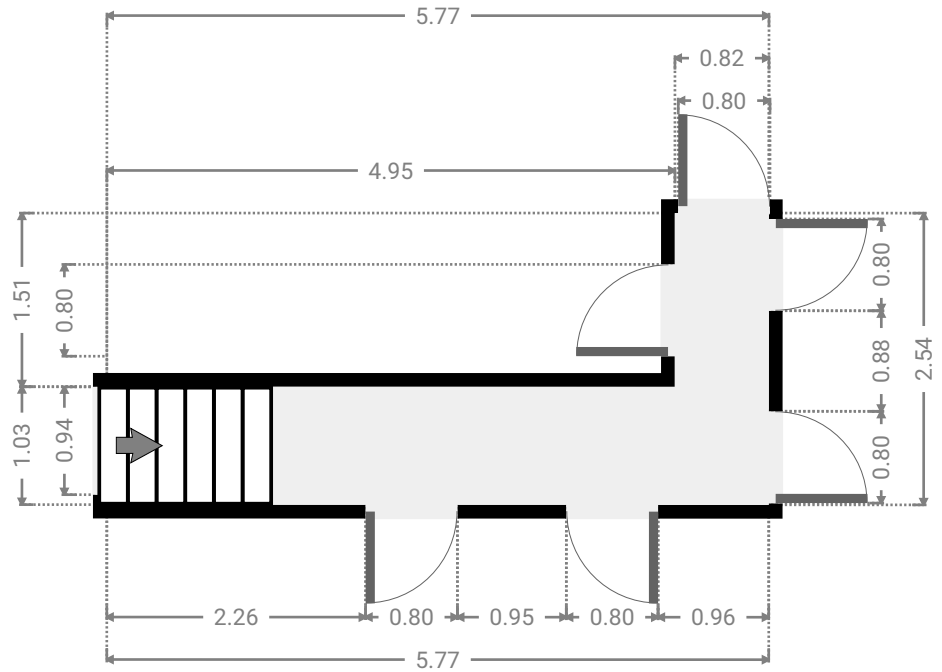
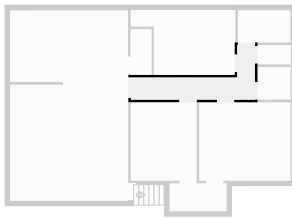

▼ **Bathroom**  
Ground Floor

WIDTH: 2.44 m • LENGTH: 1.50 m  
AREA: 3.66 m<sup>2</sup> • PERIMETER: 7.88 m

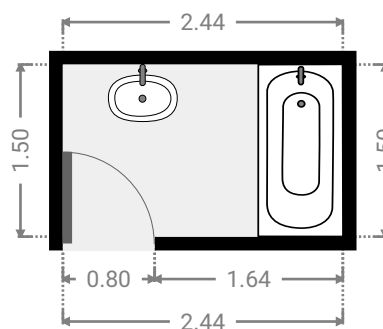
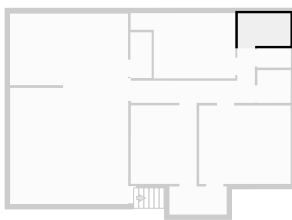

▼ **Bedroom**  
Ground Floor

WIDTH: 4.88 m • LENGTH: 3.04 m  
AREA: 12.38 m<sup>2</sup> • PERIMETER: 15.83 m

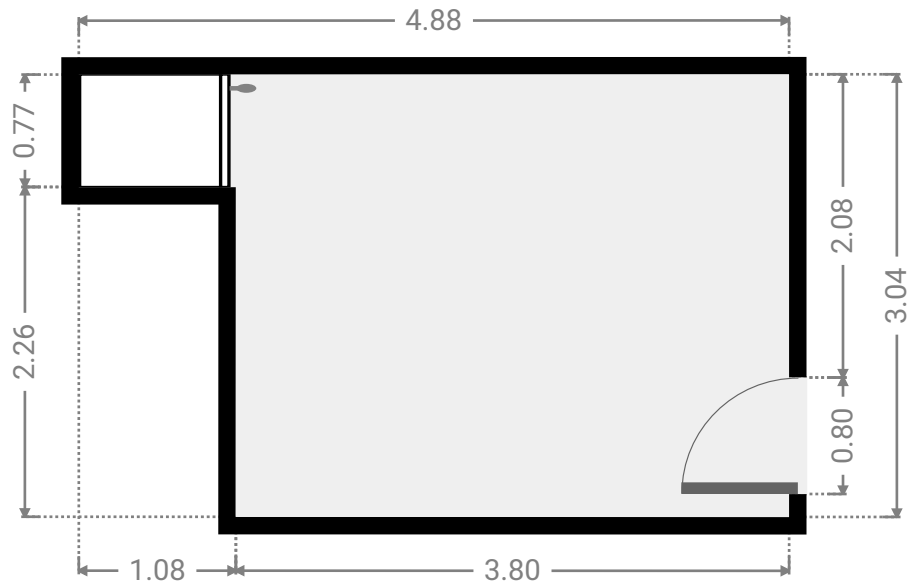
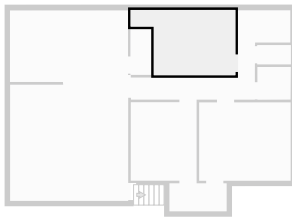

▼ **Toilet**  
Ground Floor

WIDTH: 1.57 m • LENGTH: 0.90 m  
AREA: 1.41 m<sup>2</sup> • PERIMETER: 4.94 m

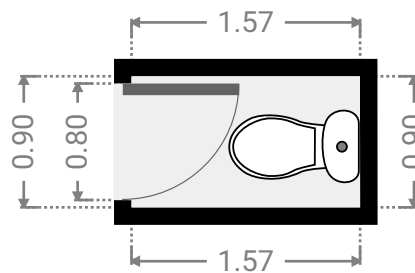



▼ **Closet**  
Ground Floor

WIDTH: 1.56 m • LENGTH: 1.54 m  
AREA: 2.36 m<sup>2</sup> • PERIMETER: 6.14 m

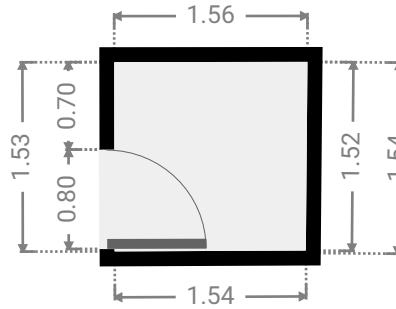

▼ **Primary Bedroom**  
Ground Floor

WIDTH: 4.26 m • LENGTH: 3.65 m  
AREA: 15.55 m<sup>2</sup> • PERIMETER: 15.82 m

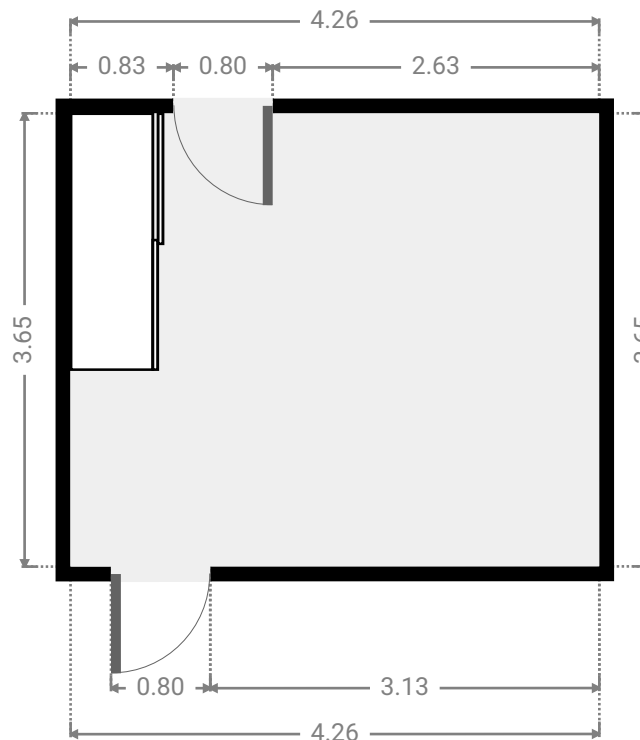
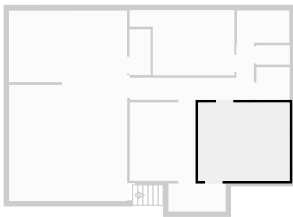

▼ **Bedroom**  
Ground Floor

WIDTH: 3.07 m • LENGTH: 3.66 m  
AREA: 11.20 m<sup>2</sup> • PERIMETER: 13.44 m

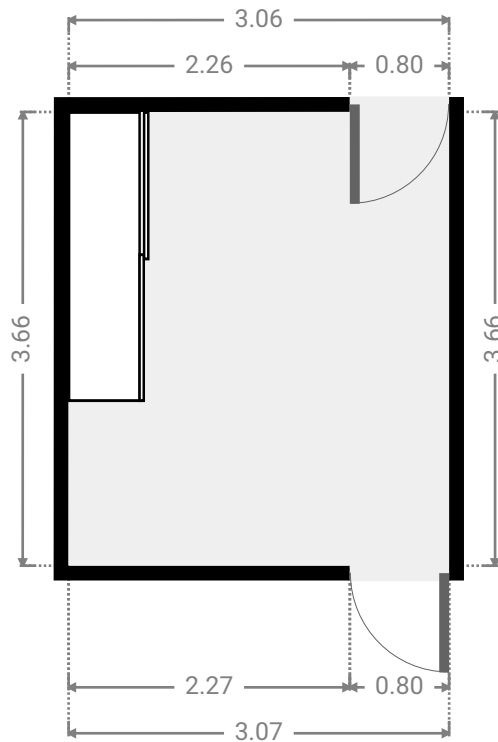
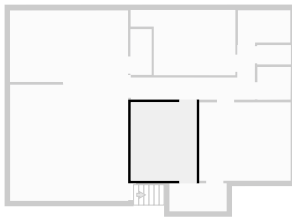

▼ **Other**  
Ground Floor

WIDTH: 2.66 m • LENGTH: 1.30 m  
AREA: 3.48 m<sup>2</sup> • PERIMETER: 7.94 m

