

21 Sage street

SUBMITTED BY

Ray White Rockhampton Casey
stockers@cqoz.com

CREATED ON

2022-03-02

Floors

2

▼ Ground Floor

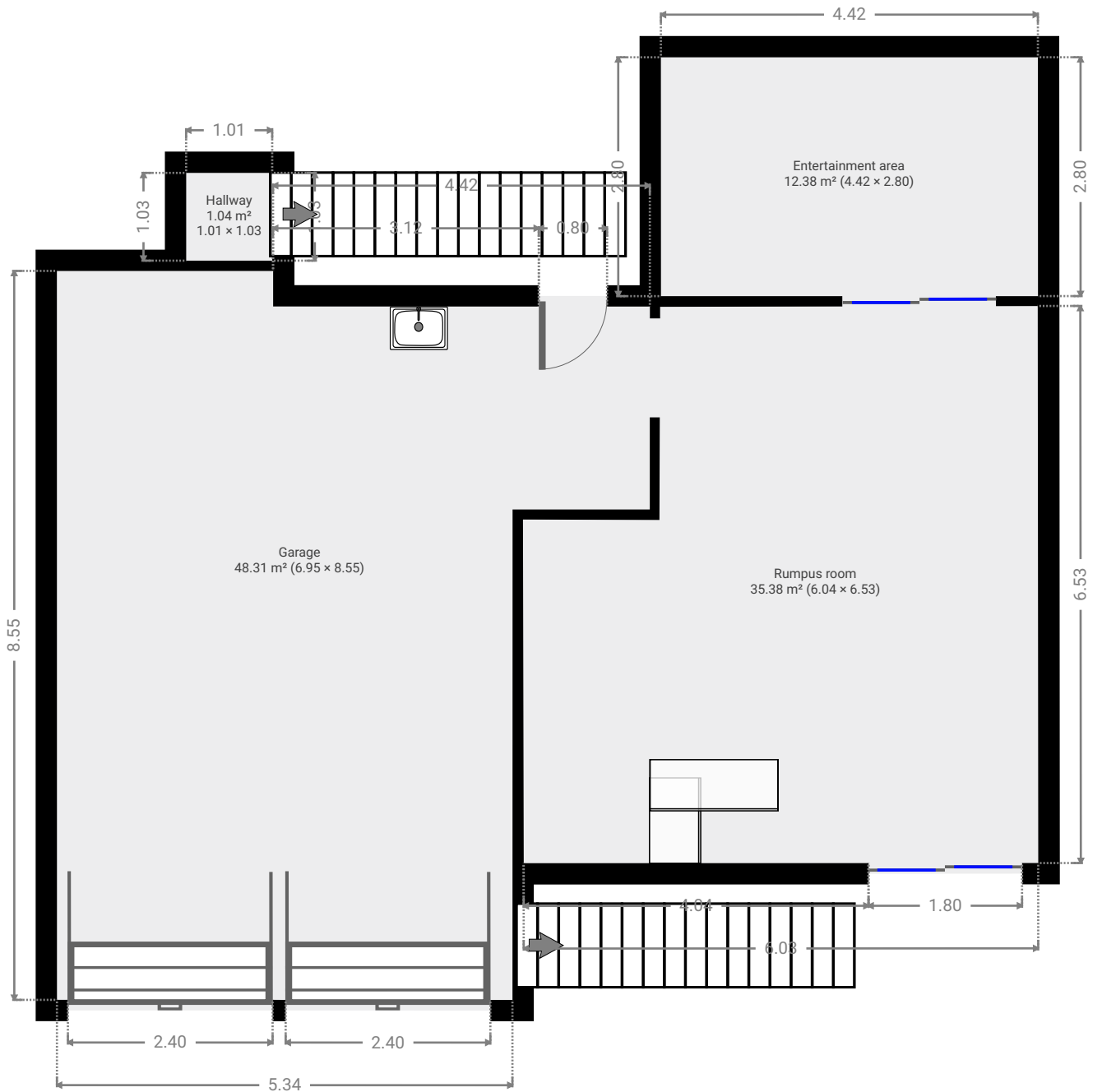

▼ Rumpus room Ground Floor

WIDTH: 6.25 m • LENGTH: 6.52 m
AREA: 35.38 m² • PERIMETER: 25.12 m

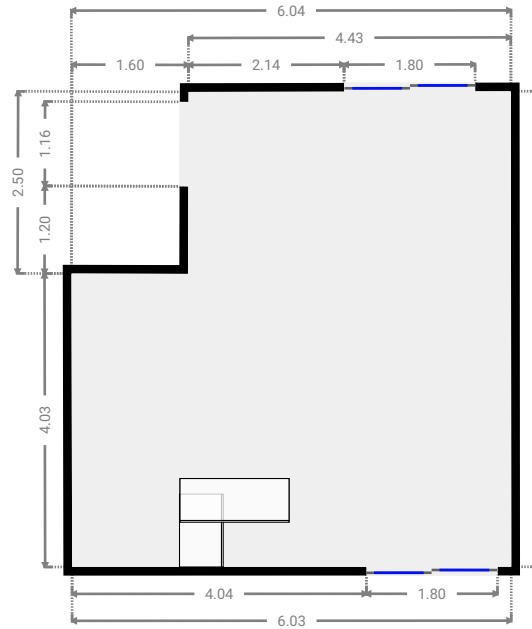
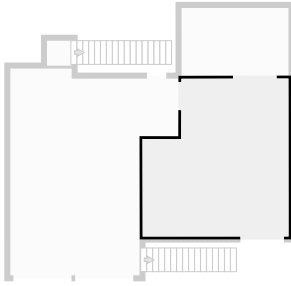

▼ Garage Ground Floor

WIDTH: 6.94 m • LENGTH: 8.55 m
AREA: 48.31 m² • PERIMETER: 30.99 m

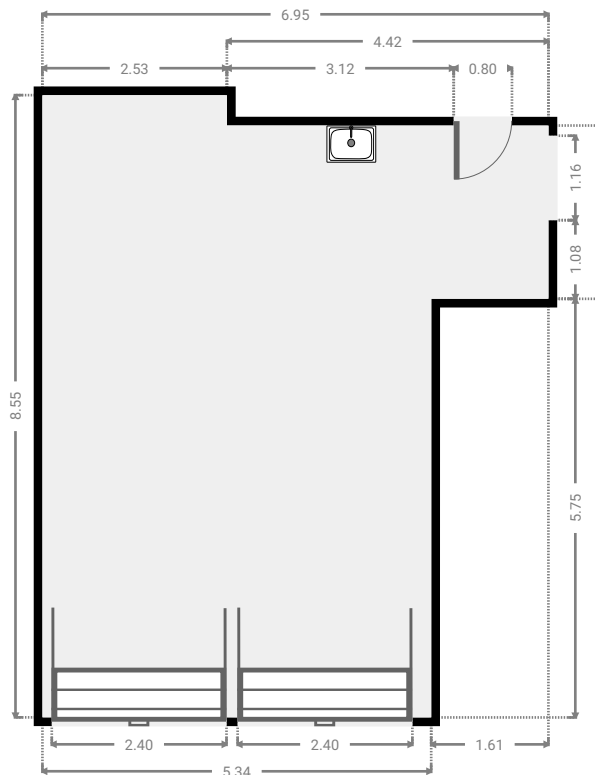
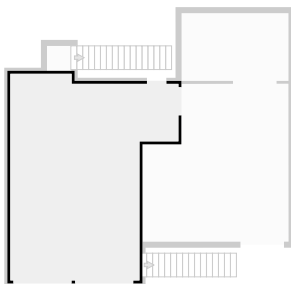

▼ Hallway Ground Floor

WIDTH: 1.01 m • LENGTH: 1.03 m
AREA: 1.04 m² • PERIMETER: 4.08 m

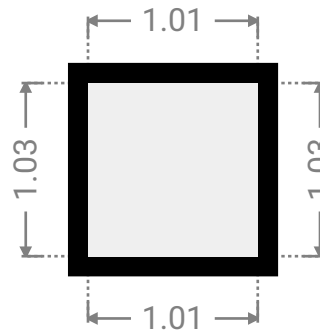
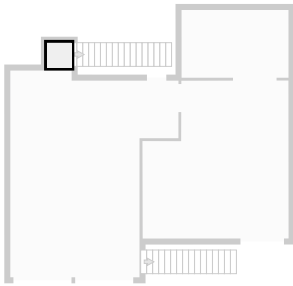

▼ Entertainment area Ground Floor

WIDTH: 4.42 m • LENGTH: 2.80 m
AREA: 12.38 m² • PERIMETER: 14.44 m

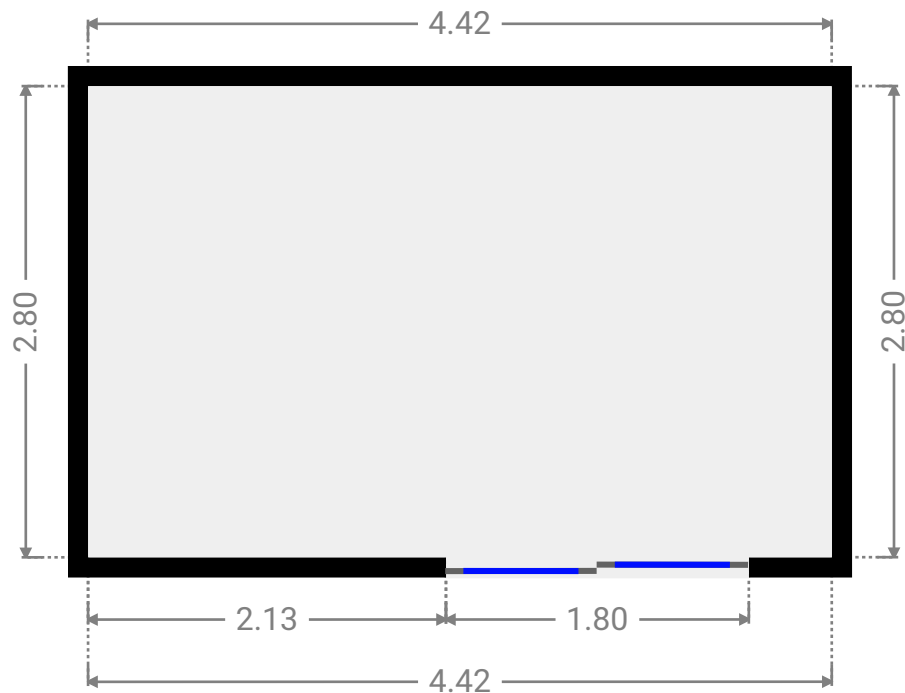
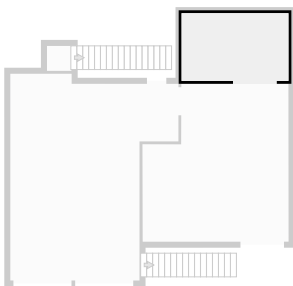

▼ 1st Floor

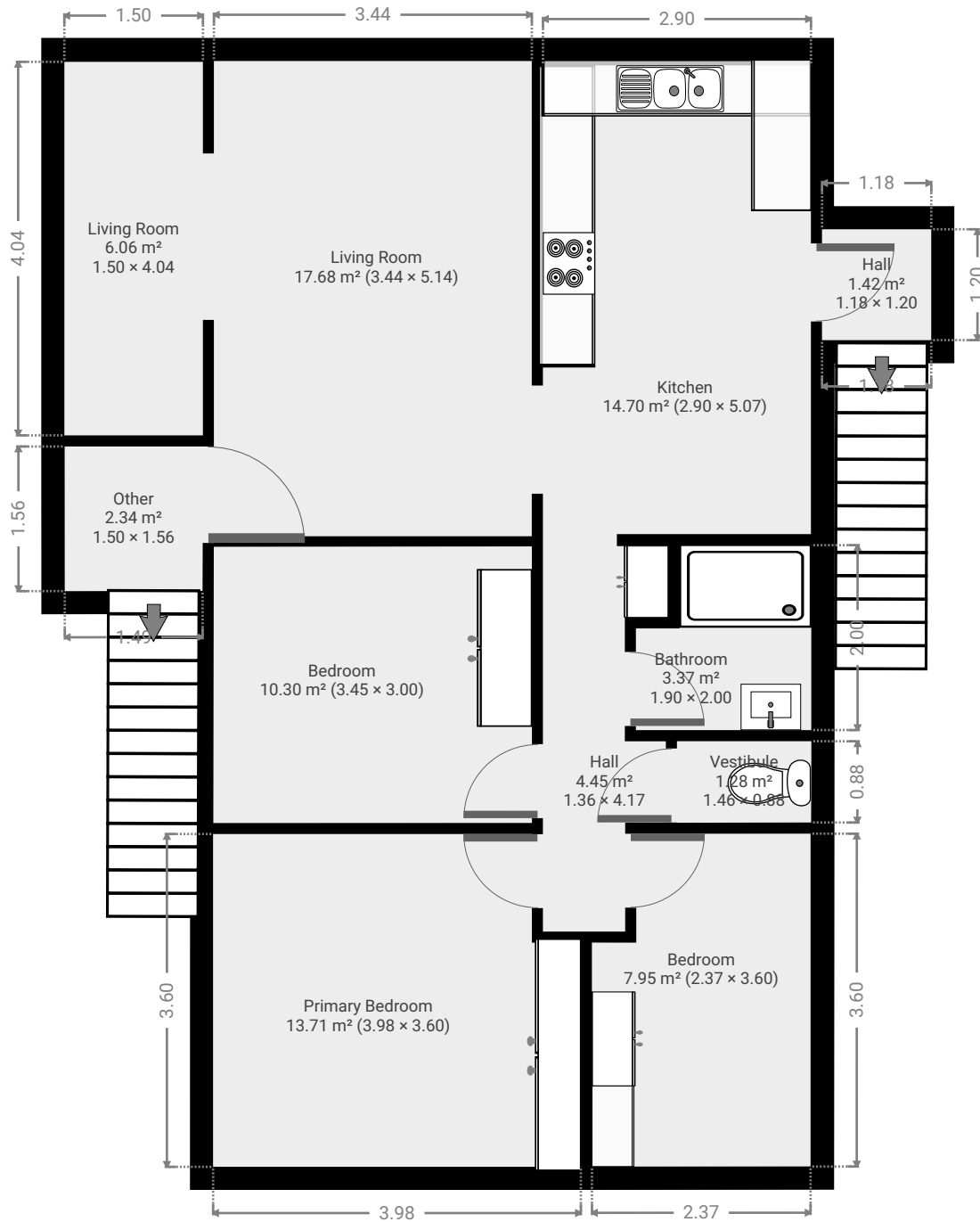

▼ Living Room 1st Floor

WIDTH: 5.14 m • LENGTH: 3.44 m
AREA: 17.68 m² • PERIMETER: 17.16 m

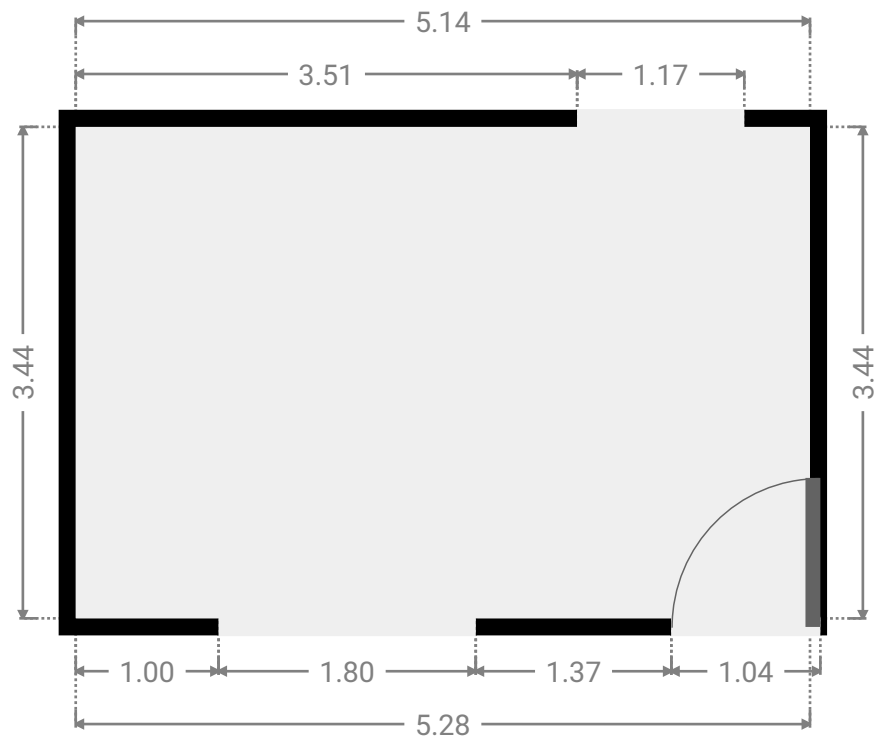
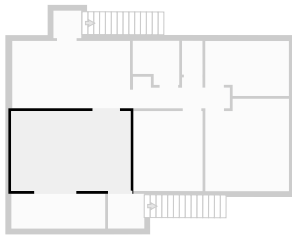

▼ Living Room 1st Floor

WIDTH: 4.04 m • LENGTH: 1.50 m
AREA: 6.06 m² • PERIMETER: 11.08 m

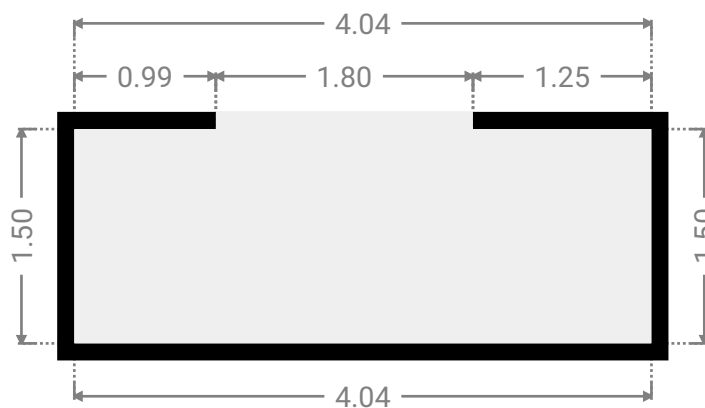
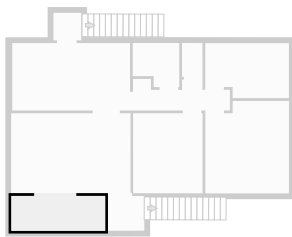

▼ **Kitchen**
1st Floor

WIDTH: 5.07 m • LENGTH: 2.90 m
AREA: 14.70 m² • PERIMETER: 15.94 m

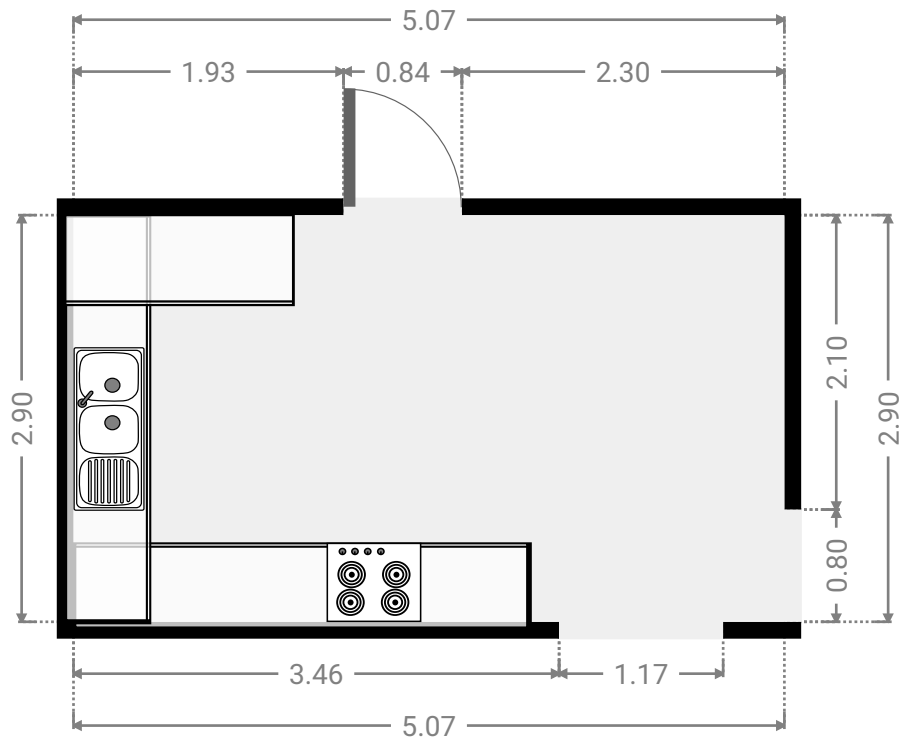
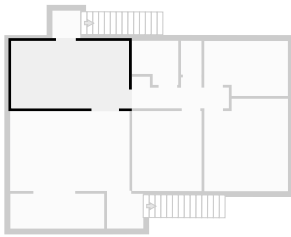

▼ **Hall**
1st Floor

WIDTH: 4.17 m • LENGTH: 1.36 m
AREA: 4.45 m² • PERIMETER: 11.94 m

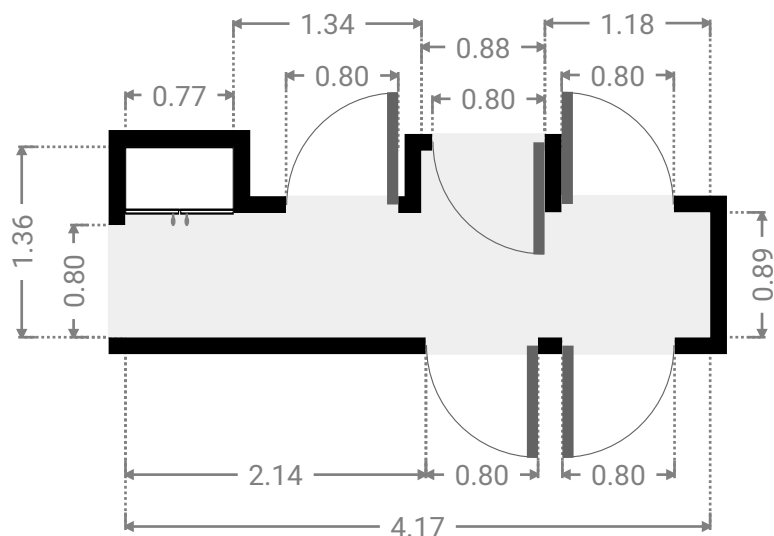
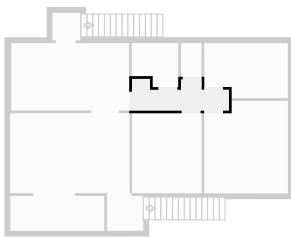

▼ **Bathroom**
1st Floor

WIDTH: 2.00 m • LENGTH: 1.90 m
AREA: 3.37 m² • PERIMETER: 7.80 m

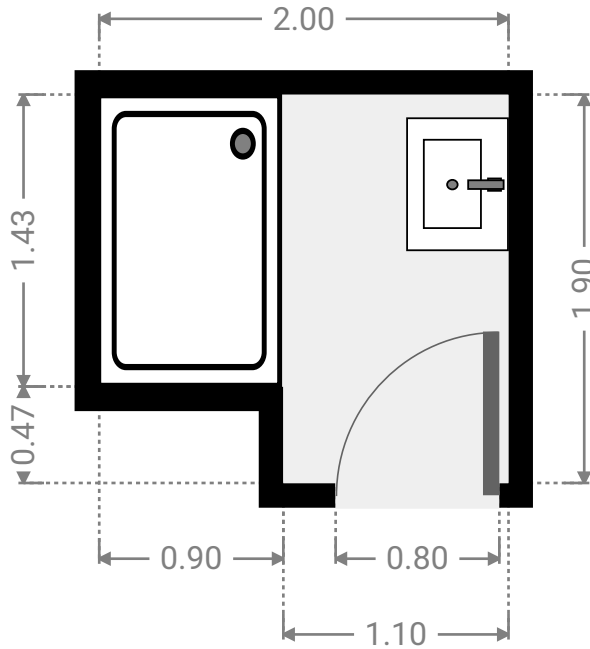
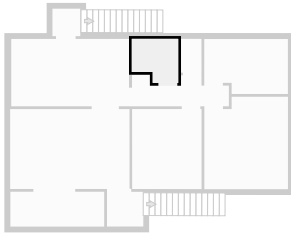

▼ **Vestibule**
1st Floor

WIDTH: 0.88 m • LENGTH: 1.46 m
AREA: 1.28 m² • PERIMETER: 4.67 m

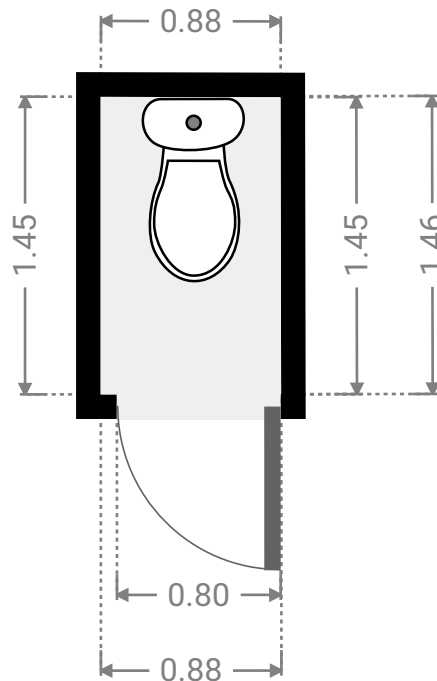
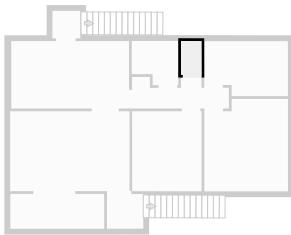

▼ **Bedroom**
1st Floor

WIDTH: 3.60 m • LENGTH: 2.37 m
AREA: 7.95 m² • PERIMETER: 11.93 m

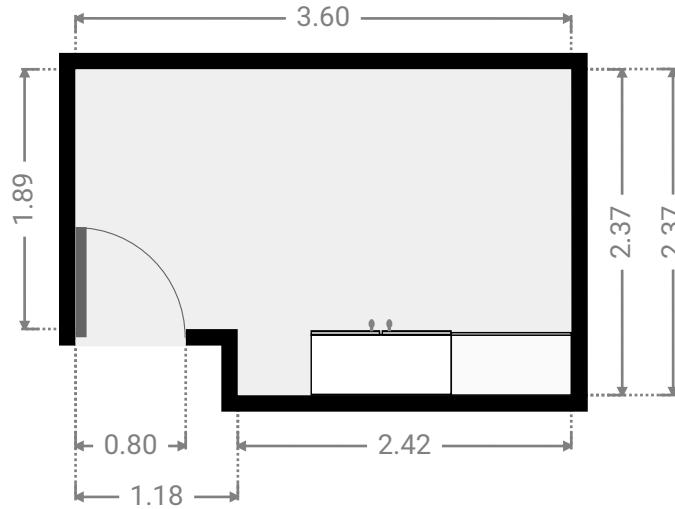
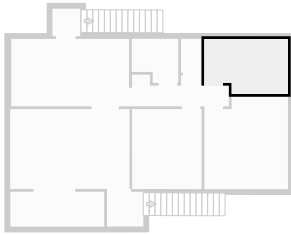

▼ **Primary Bedroom**
1st Floor

WIDTH: 3.60 m • LENGTH: 3.98 m
AREA: 13.71 m² • PERIMETER: 15.16 m

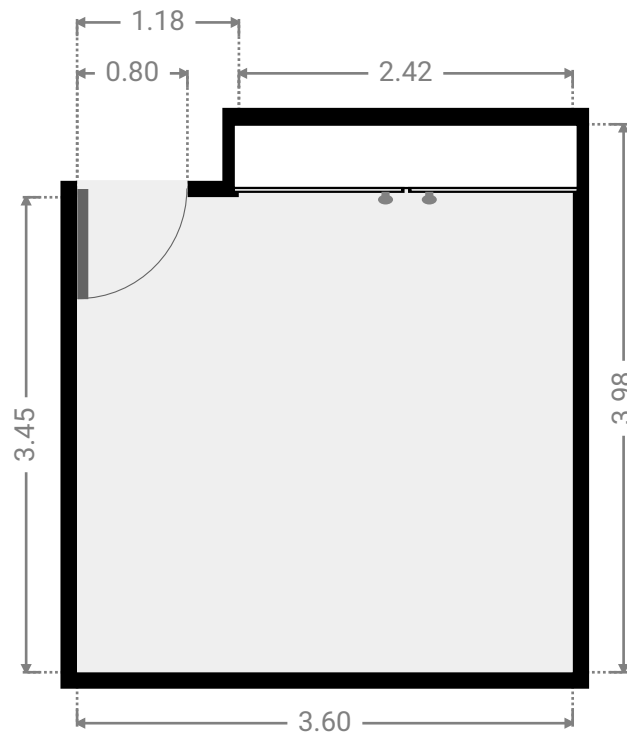
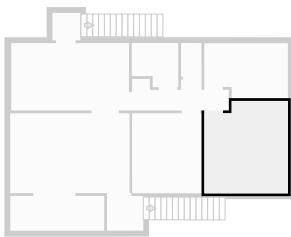

▼ **Bedroom**
1st Floor

WIDTH: 3.00 m • LENGTH: 3.45 m
AREA: 10.30 m² • PERIMETER: 12.87 m

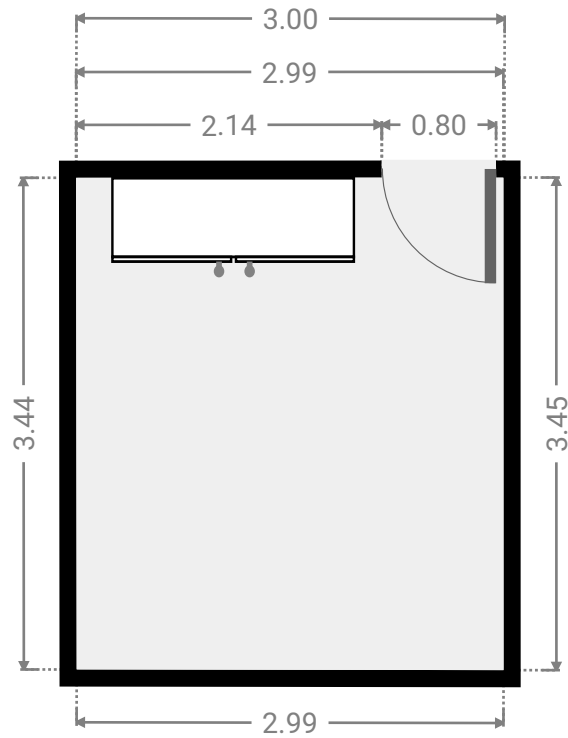
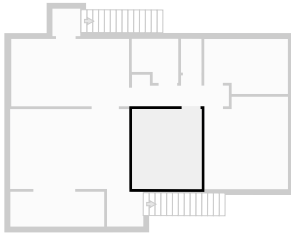

▼ **Other**
1st Floor

WIDTH: 1.56 m • LENGTH: 1.50 m
AREA: 2.34 m² • PERIMETER: 6.12 m

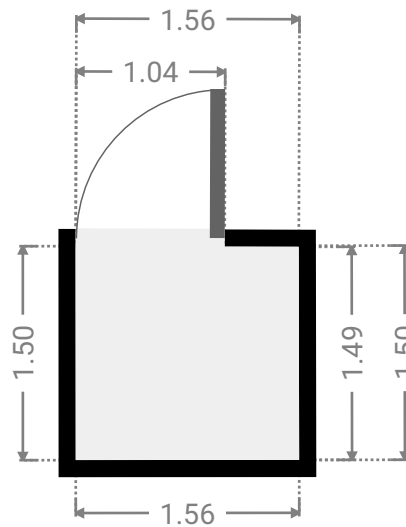
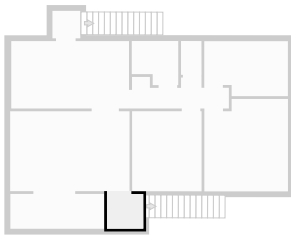

▼ **Hall**
1st Floor

WIDTH: 1.20 m • LENGTH: 1.18 m
AREA: 1.42 m² • PERIMETER: 4.76 m

