

21 Booker Street

Created on
2018-09-28

Floors
2

▼ Ground Floor

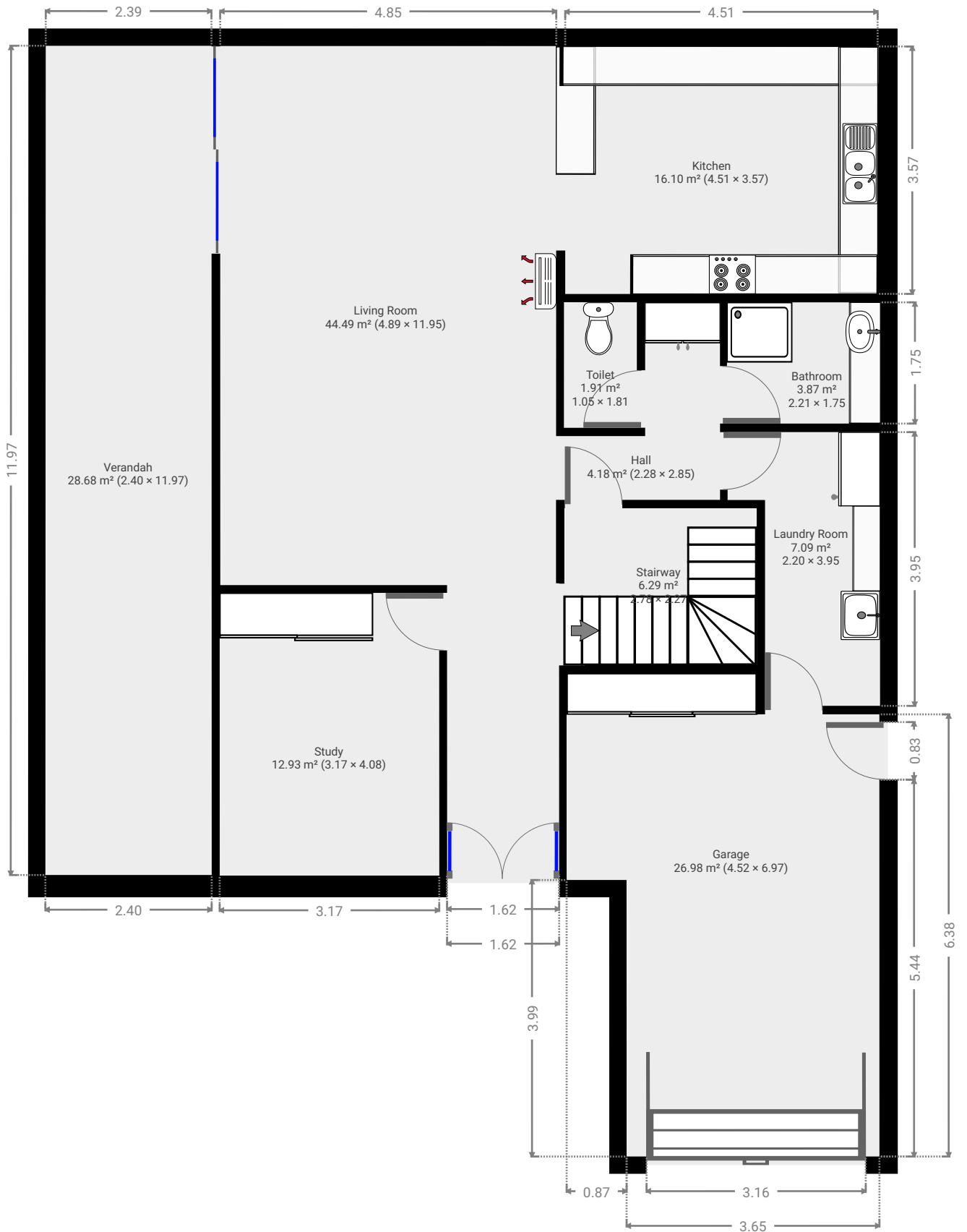

▼ Living Room
Ground Floor

WIDTH: 4.99 m • LENGTH: 11.95 m
AREA: 44.49 m² • PERIMETER: 33.69 m

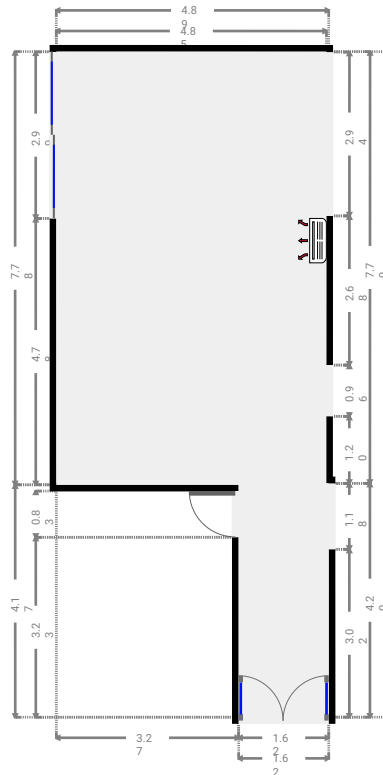
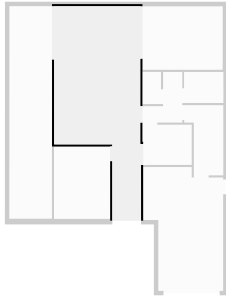

▼ Study
Ground Floor

WIDTH: 3.17 m • LENGTH: 4.08 m
AREA: 12.93 m² • PERIMETER: 14.50 m

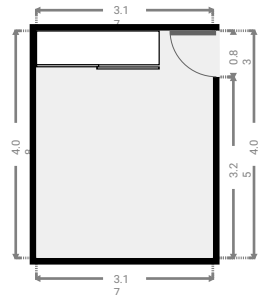
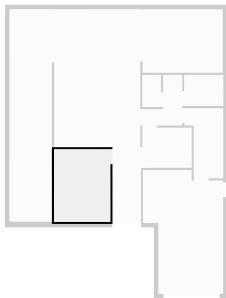

▼ **Kitchen**
Ground Floor

WIDTH: 4.51 m • LENGTH: 3.57 m
AREA: 16.10 m² • PERIMETER: 16.16 m

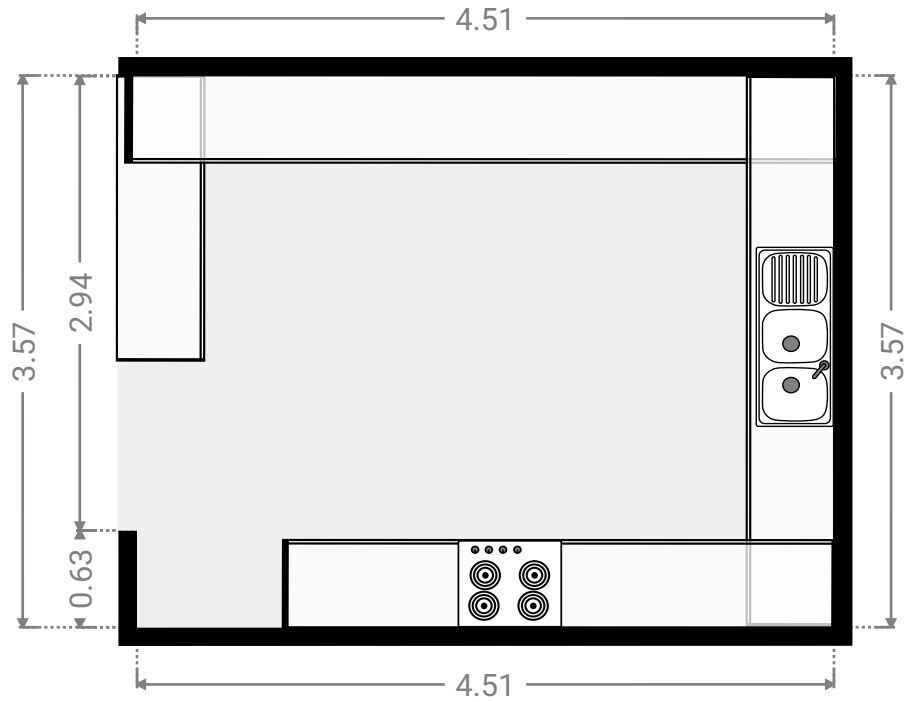
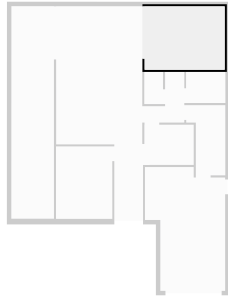

▼ **Hall**
Ground Floor

WIDTH: 2.28 m • LENGTH: 2.85 m
AREA: 4.18 m² • PERIMETER: 10.26 m

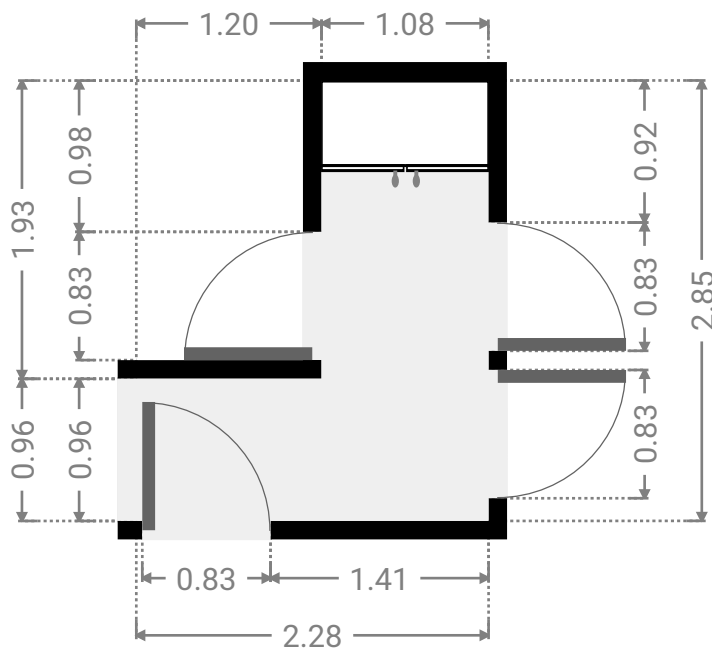
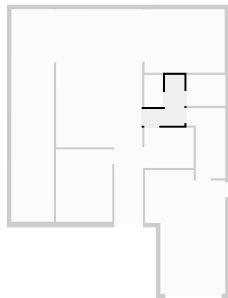

▼ **Toilet**
Ground Floor

WIDTH: 1.06 m • LENGTH: 1.81 m
AREA: 1.91 m² • PERIMETER: 5.73 m

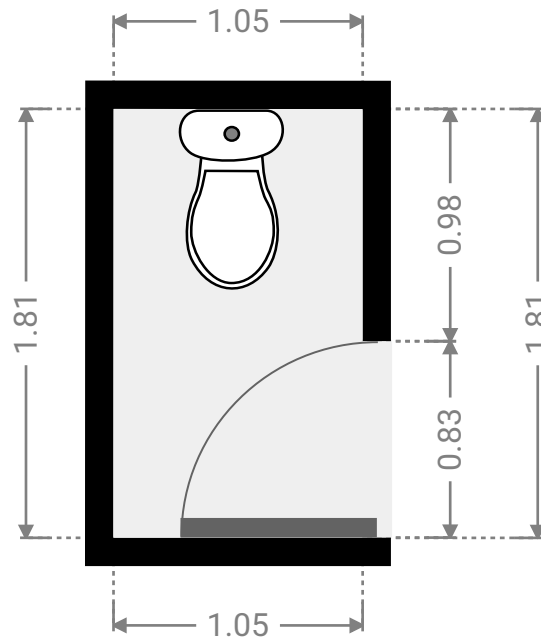
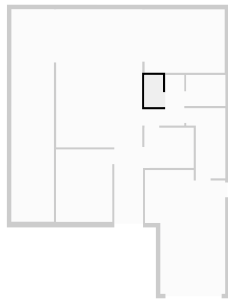

▼ **Bathroom**
Ground Floor

WIDTH: 2.21 m • LENGTH: 1.75 m
AREA: 3.87 m² • PERIMETER: 7.93 m

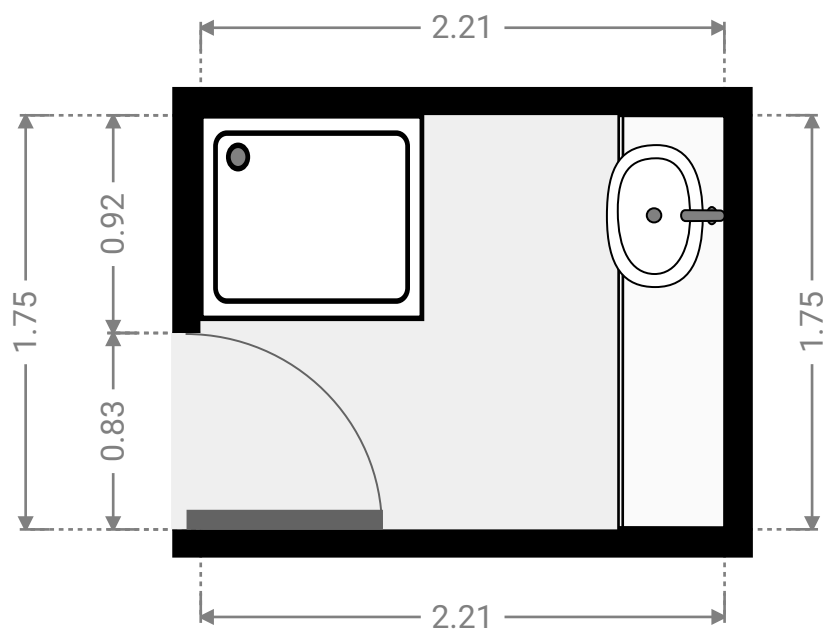
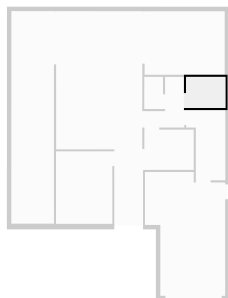

▼ Laundry Room
Ground Floor

WIDTH: 2.20 m • LENGTH: 3.95 m
AREA: 7.09 m² • PERIMETER: 12.30 m

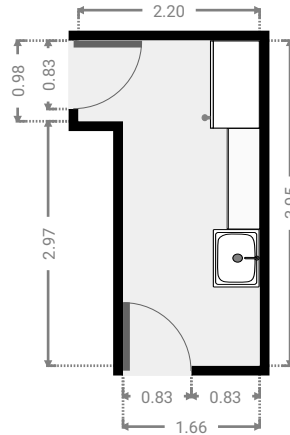
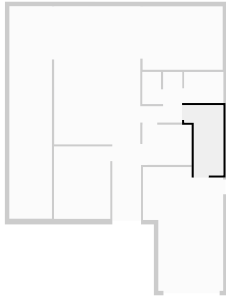

▼ Garage
Ground Floor

WIDTH: 4.43 m • LENGTH: 6.97 m
AREA: 26.98 m² • PERIMETER: 22.97 m

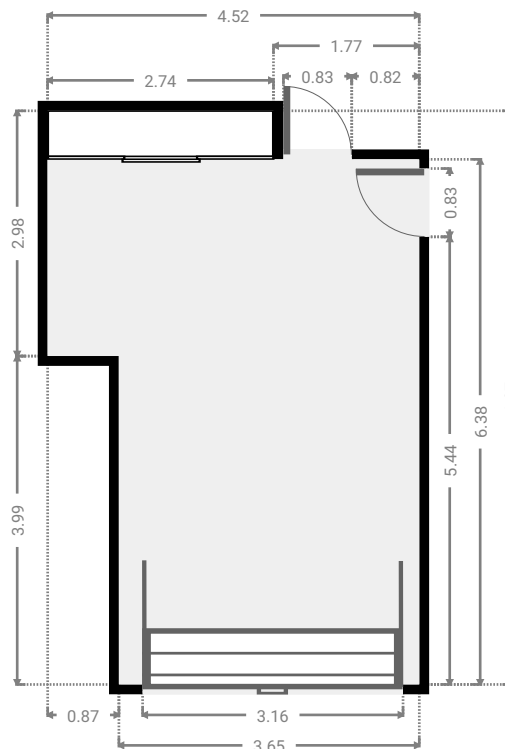
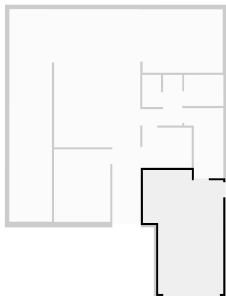

▼ **Stairway**
Ground Floor

WIDTH: 2.80 m • LENGTH: 2.27 m
AREA: 6.29 m² • PERIMETER: 10.08 m

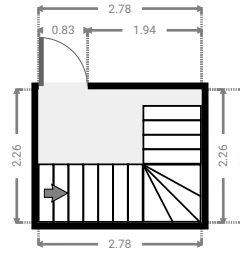
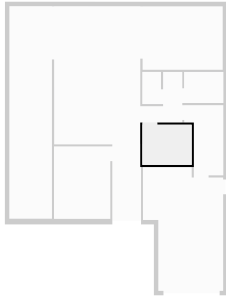

▼ **Verandah**
Ground Floor

WIDTH: 2.40 m • LENGTH: 11.96 m
AREA: 28.68 m² • PERIMETER: 28.73 m

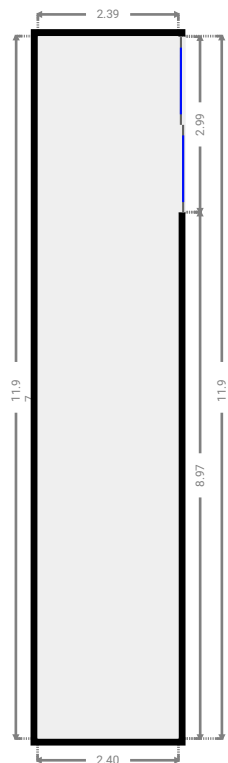
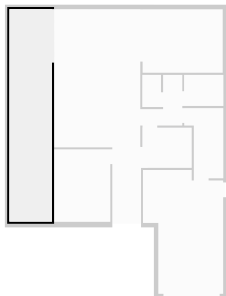

▼ 1st Floor

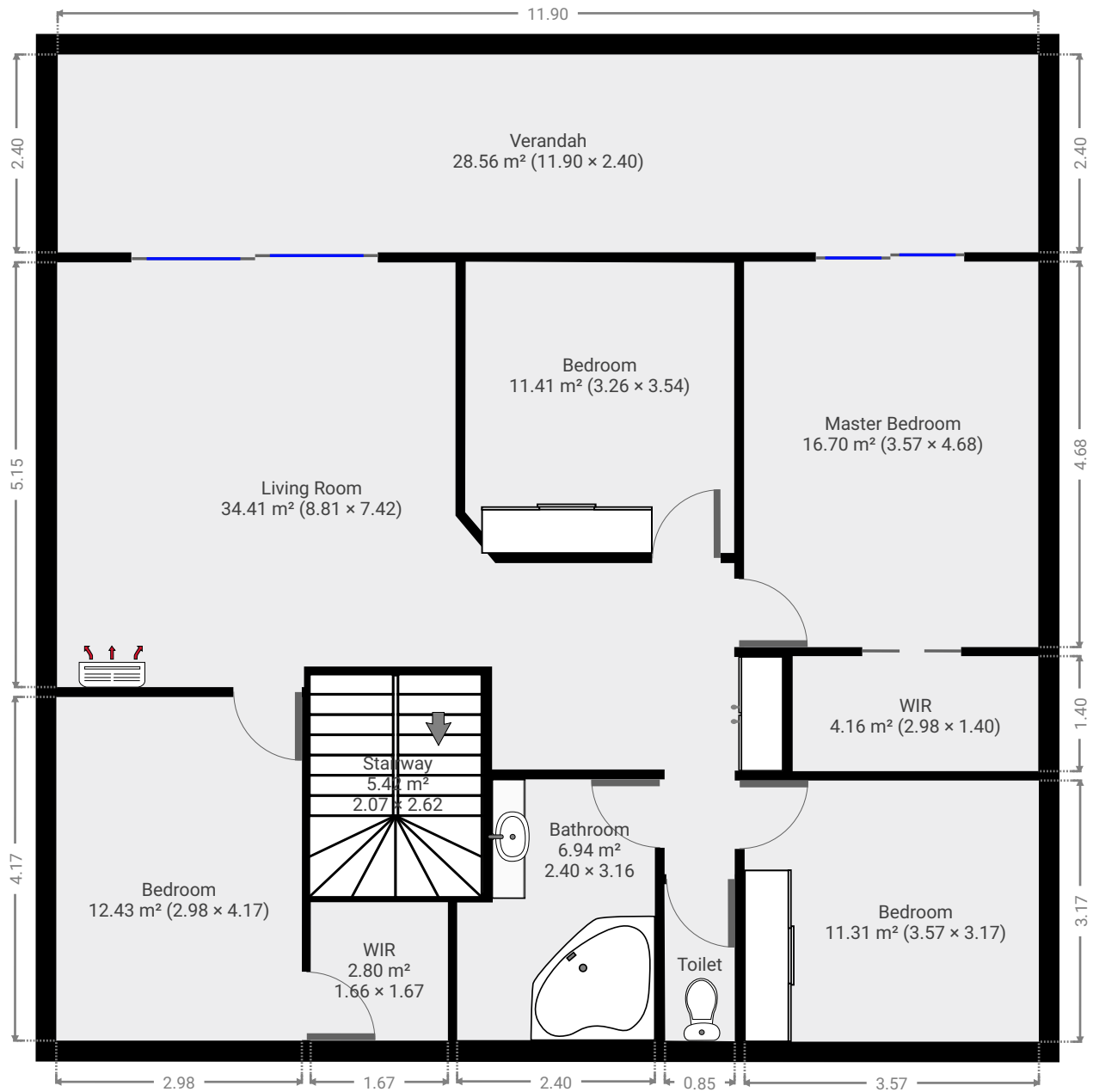

▼ Living Room
1st Floor

WIDTH: 7.42 m • LENGTH: 8.81 m
AREA: 34.41 m² • PERIMETER: 32.65 m

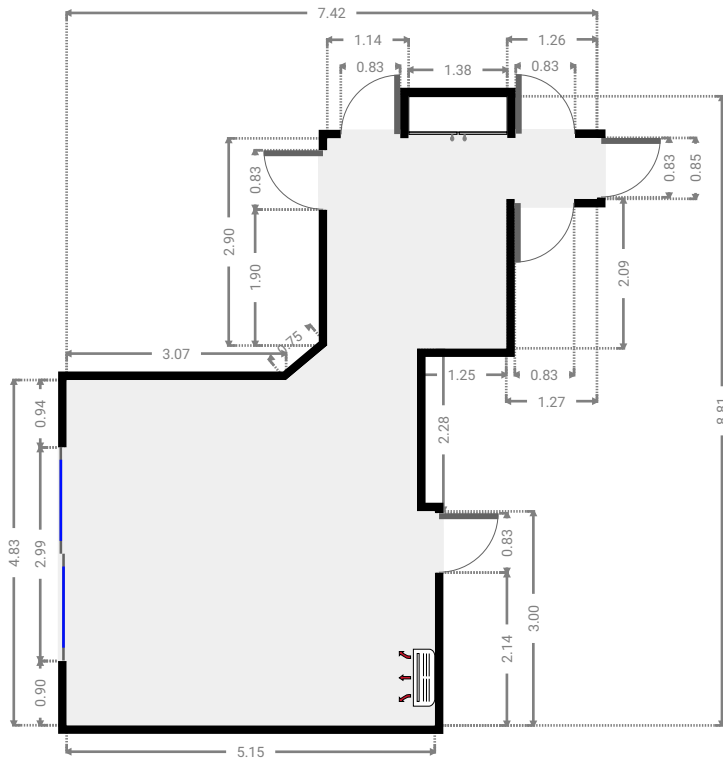
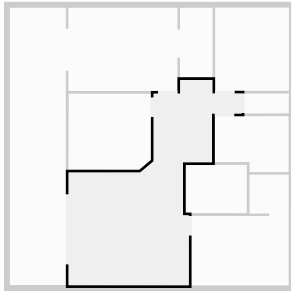

▼ Bedroom
1st Floor

WIDTH: 4.17 m • LENGTH: 2.98 m
AREA: 12.43 m² • PERIMETER: 14.30 m

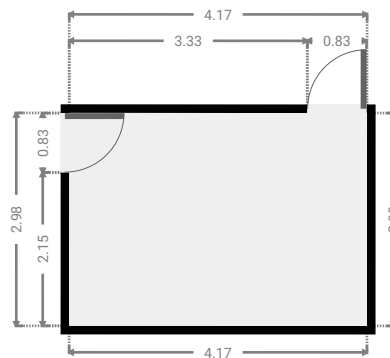
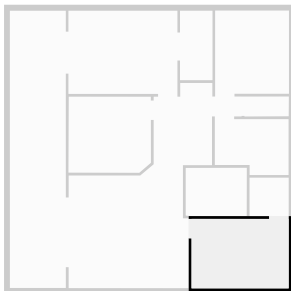

▼ **WIR**
1st Floor

WIDTH: 1.68 m • LENGTH: 1.67 m
AREA: 2.80 m² • PERIMETER: 6.69 m

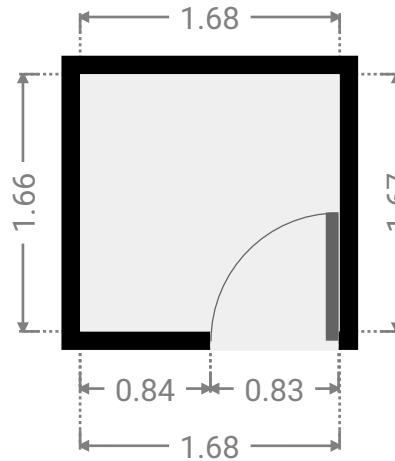
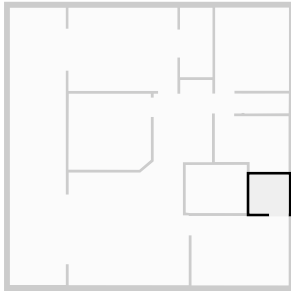

▼ **Bedroom**
1st Floor

WIDTH: 3.54 m • LENGTH: 3.26 m
AREA: 11.41 m² • PERIMETER: 13.31 m

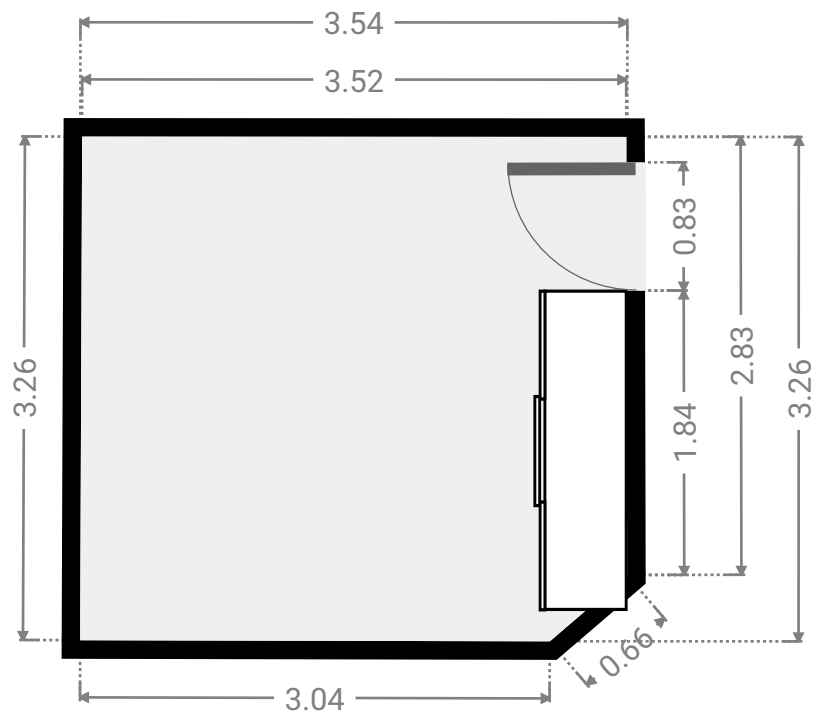
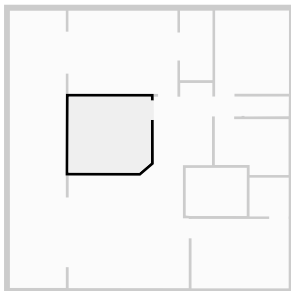

▼ Master Bedroom
1st Floor

WIDTH: 4.68 m • LENGTH: 3.57 m
AREA: 16.70 m² • PERIMETER: 16.49 m

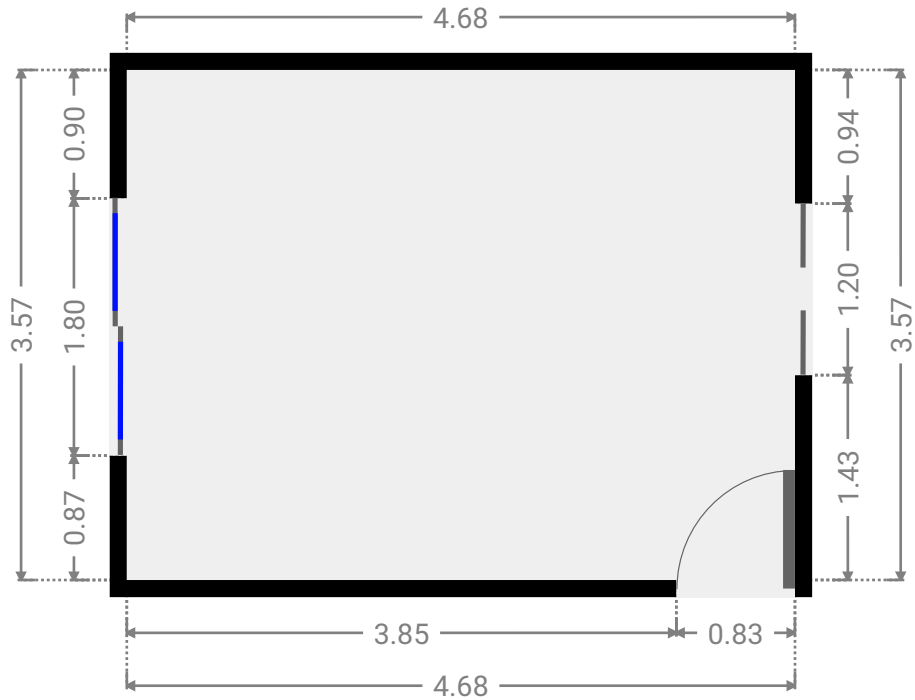
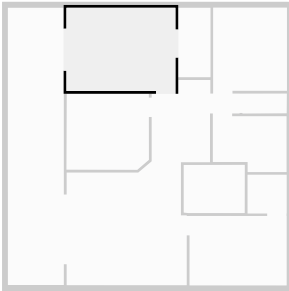

▼ WIR
1st Floor

WIDTH: 1.40 m • LENGTH: 2.98 m
AREA: 4.16 m² • PERIMETER: 8.75 m

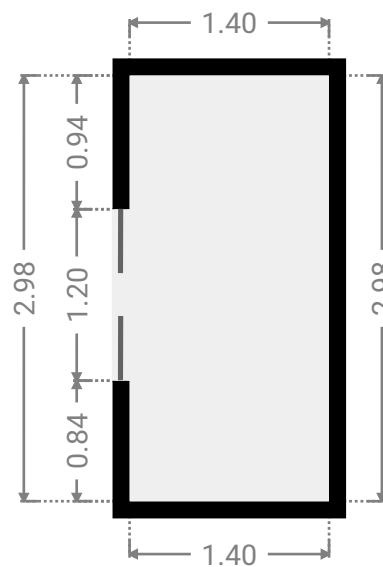
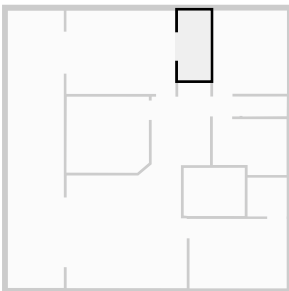

▼ **Bedroom**
1st Floor

WIDTH: 3.17 m • LENGTH: 3.57 m
AREA: 11.31 m² • PERIMETER: 13.48 m

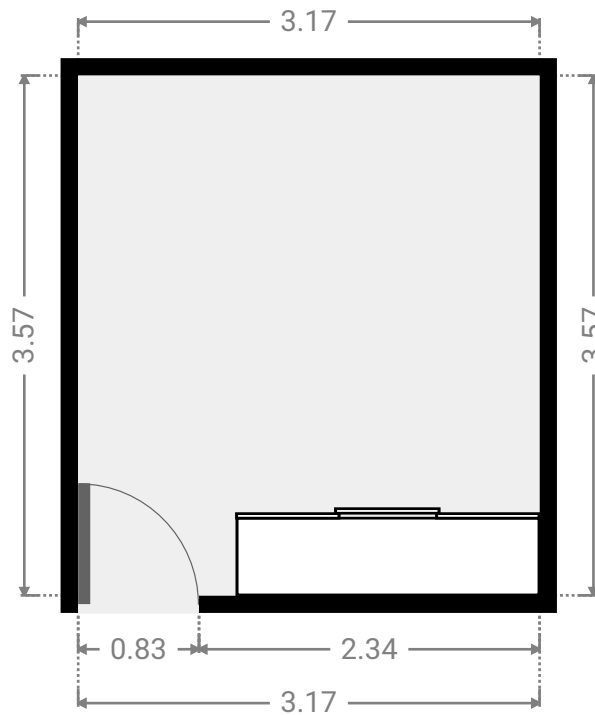
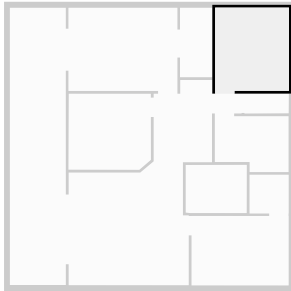

▼ **Bathroom**
1st Floor

WIDTH: 3.16 m • LENGTH: 2.40 m
AREA: 6.94 m² • PERIMETER: 11.13 m

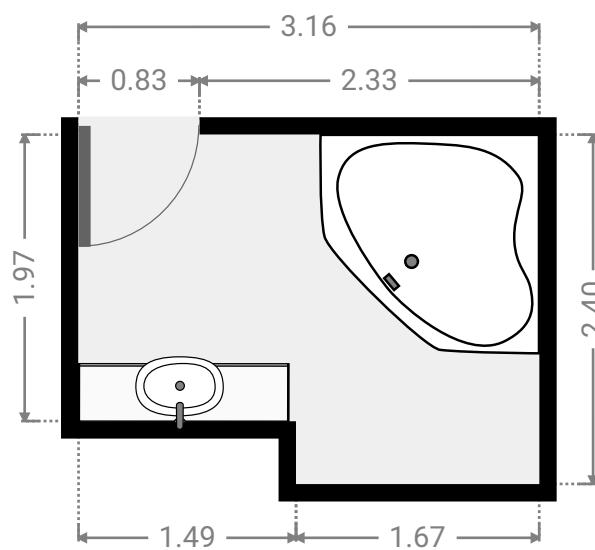
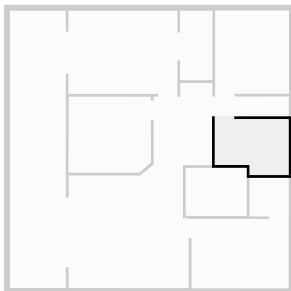

▼ Toilet
1st Floor

WIDTH: 1.91 m • LENGTH: 0.87 m
AREA: 1.62 m² • PERIMETER: 5.51 m

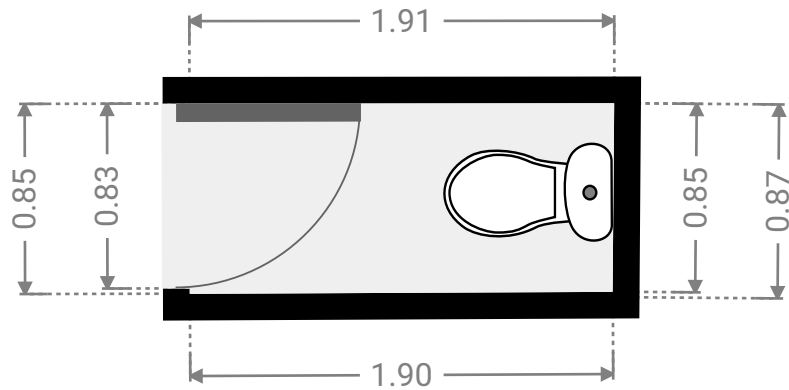
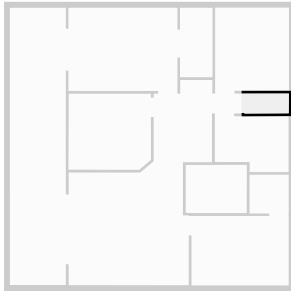

▼ Stairway
1st Floor

WIDTH: 2.62 m • LENGTH: 2.07 m
AREA: 5.42 m² • PERIMETER: 9.36 m

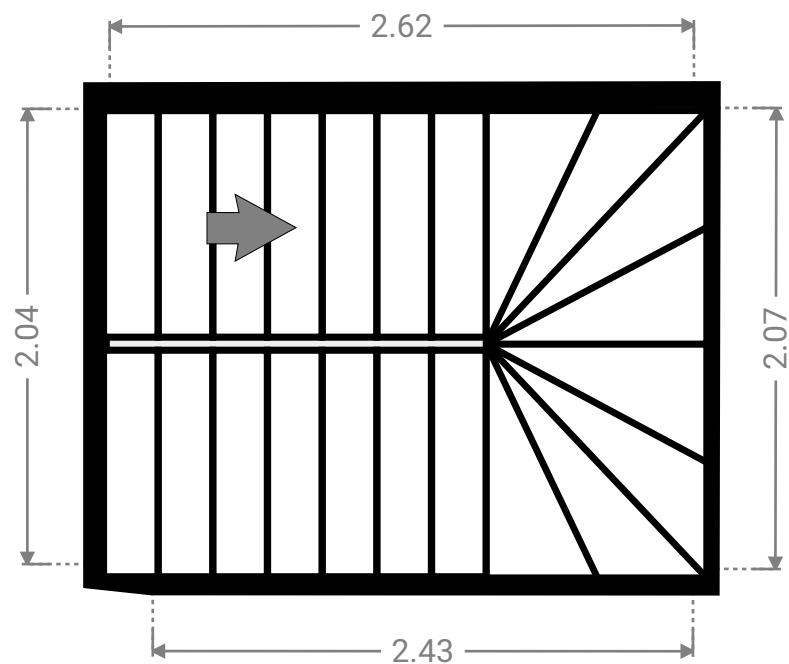
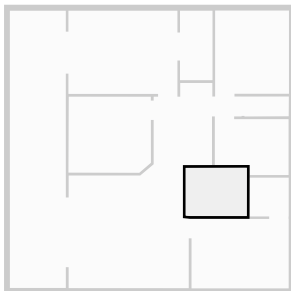

▼ Verandah
1st Floor

WIDTH: 2.40 m • LENGTH: 11.90 m
AREA: 28.56 m² • PERIMETER: 28.60 m

