

# 204 Earl Street

**SUBMITTED BY**

Ray White Rockhampton Casey  
stockers@cqoz.com

---

**CREATED ON**

2021-11-23

---

**Floors**

2

---

▼ Ground Floor

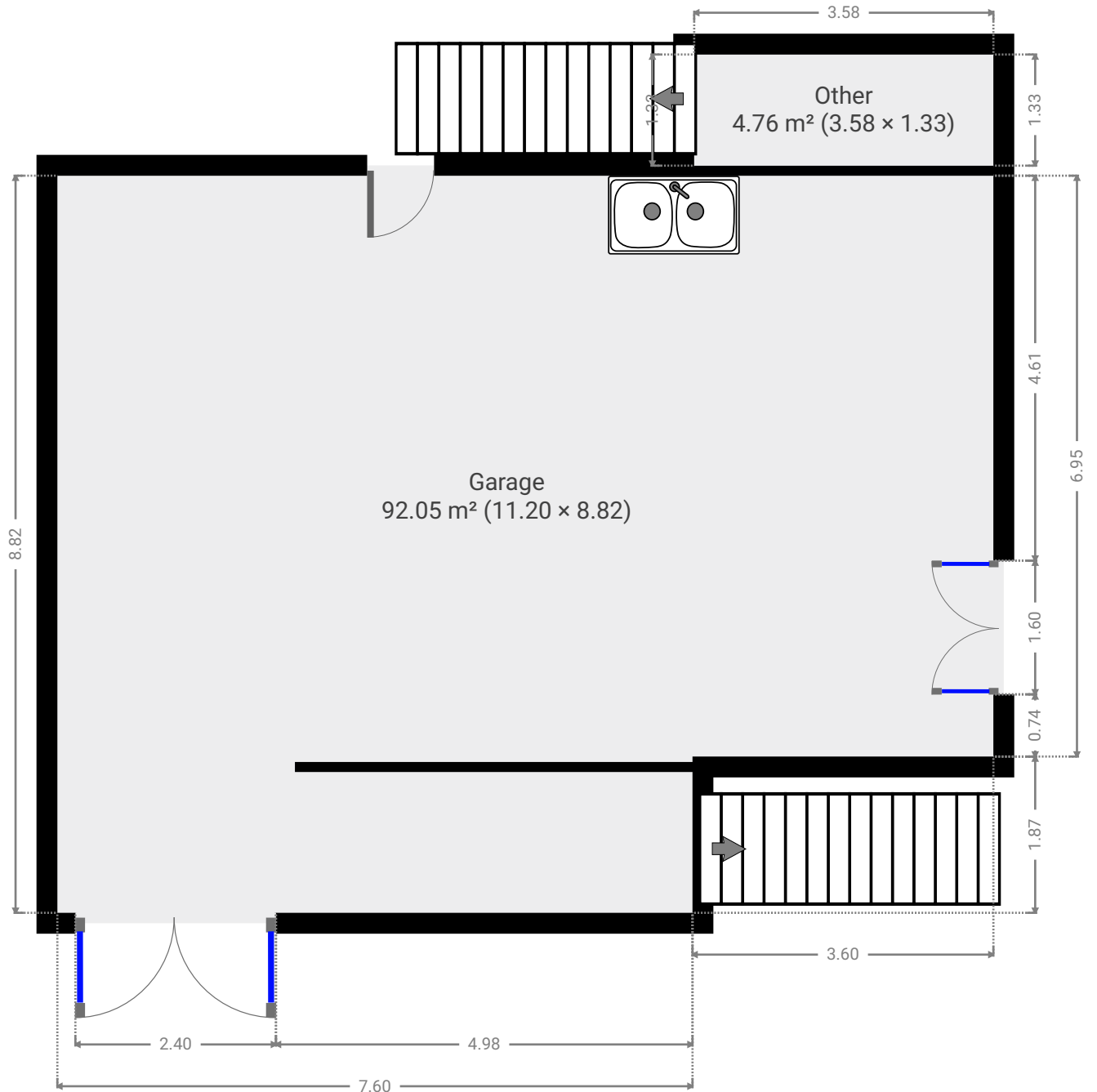

▼ **Garage**  
Ground Floor

WIDTH: 11.20 m • LENGTH: 8.82 m  
AREA: 92.05 m<sup>2</sup> • PERIMETER: 40.04 m

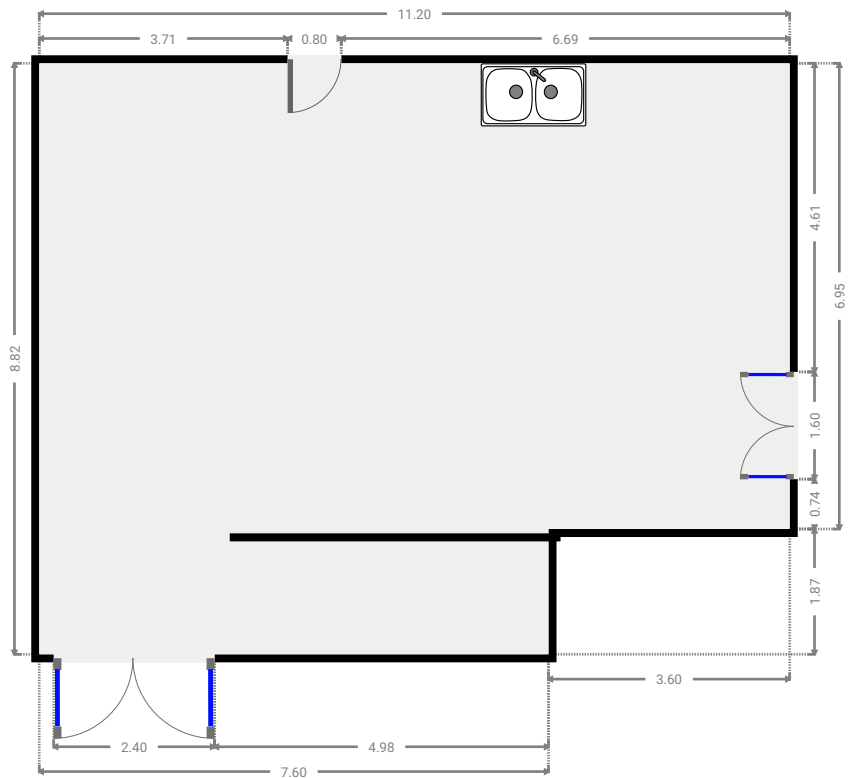
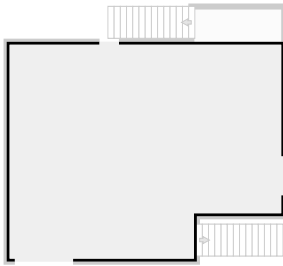

▼ **Other**  
Ground Floor

WIDTH: 3.58 m • LENGTH: 1.33 m  
AREA: 4.76 m<sup>2</sup> • PERIMETER: 9.82 m

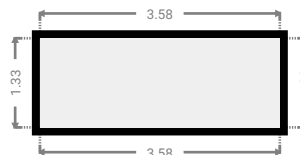
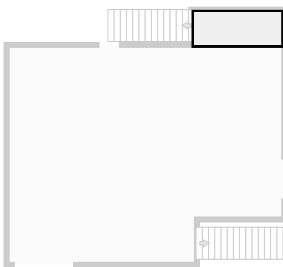

▼ 1st Floor

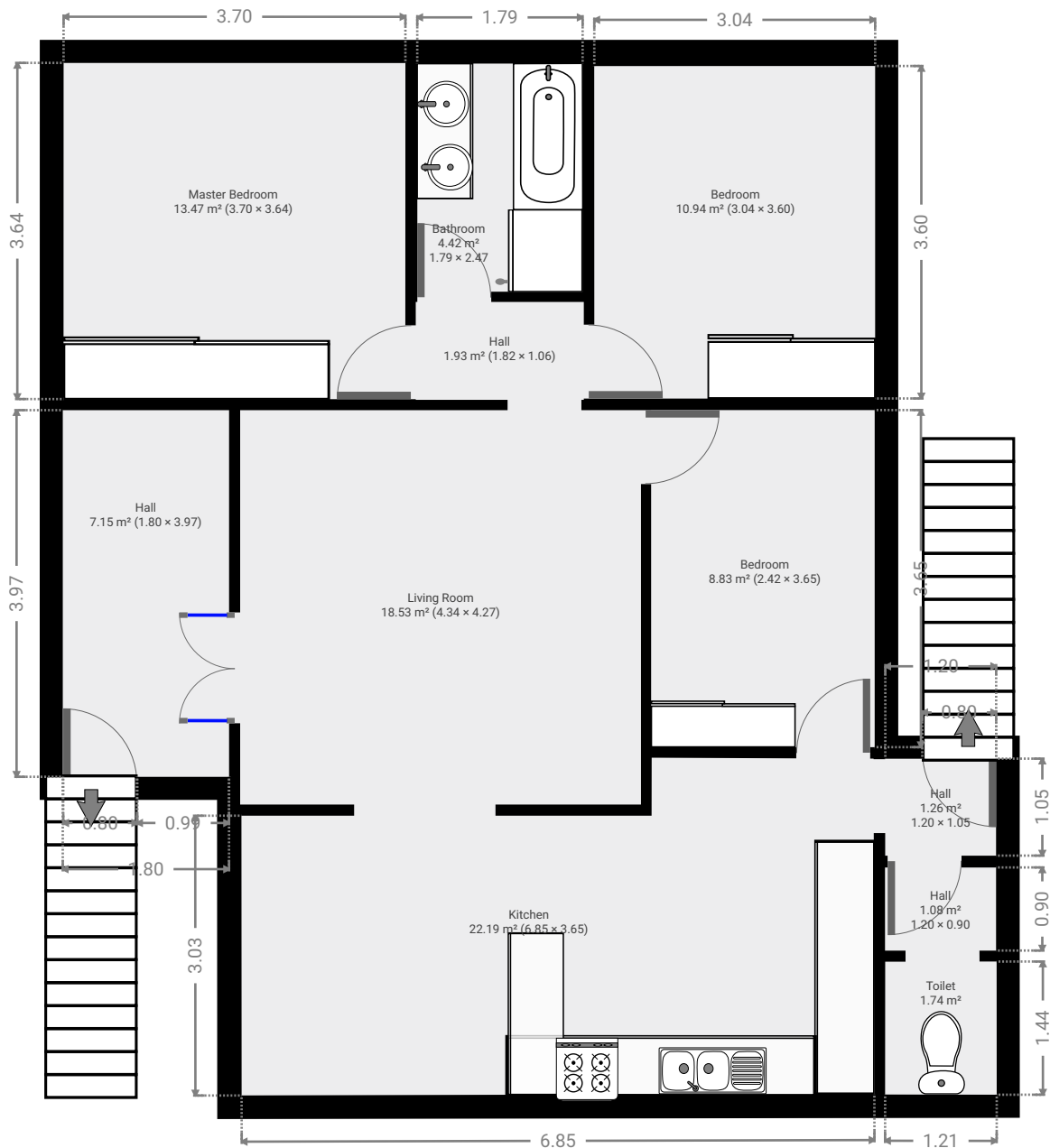

▼ Hall  
1st Floor

WIDTH: 3.97 m • LENGTH: 1.80 m  
AREA: 7.15 m<sup>2</sup> • PERIMETER: 11.54 m

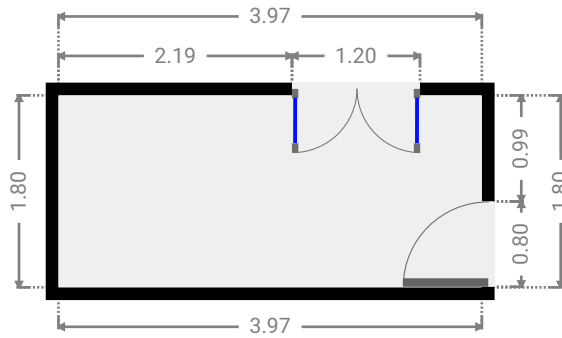
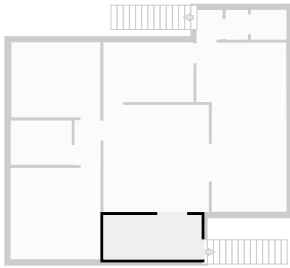

▼ Living Room  
1st Floor

WIDTH: 4.27 m • LENGTH: 4.34 m  
AREA: 18.53 m<sup>2</sup> • PERIMETER: 17.22 m

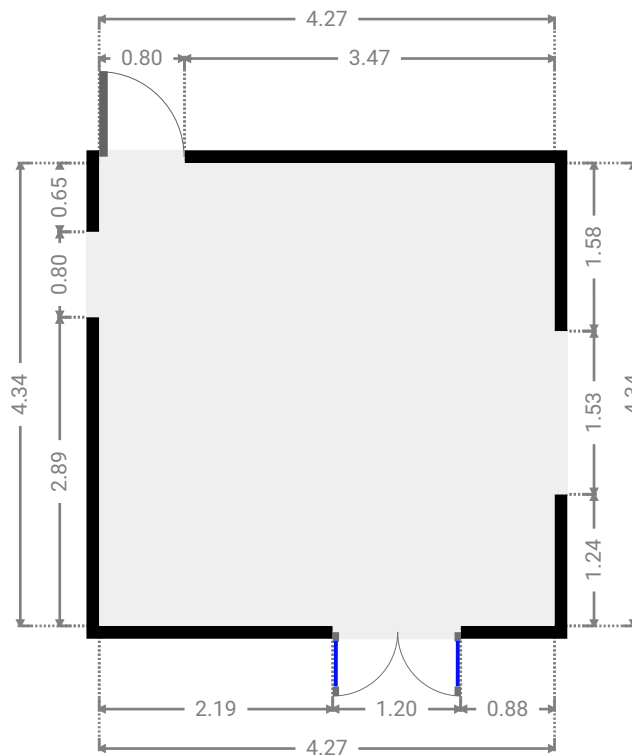
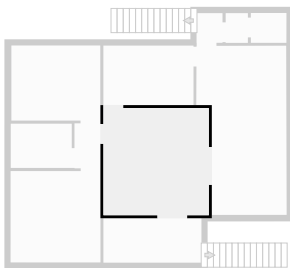

▼ **Kitchen**  
1st Floor

WIDTH: 3.65 m • LENGTH: 6.85 m  
AREA: 22.19 m<sup>2</sup> • PERIMETER: 20.98 m

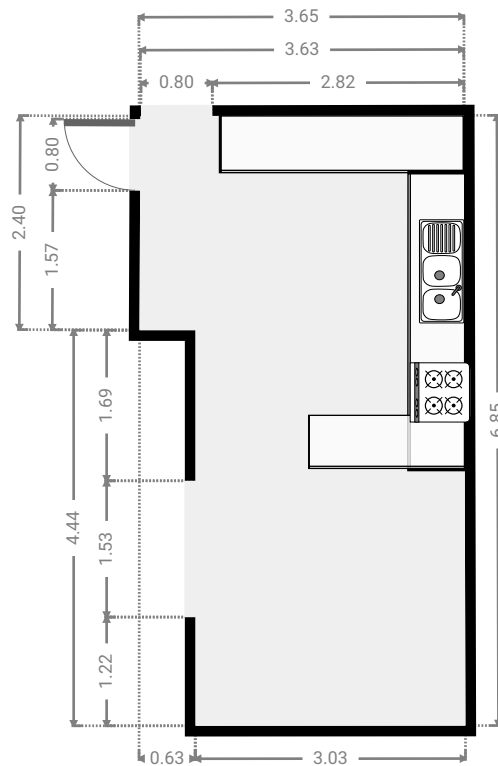
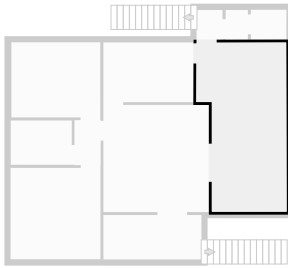

▼ **Hall**  
1st Floor

WIDTH: 1.05 m • LENGTH: 1.20 m  
AREA: 1.26 m<sup>2</sup> • PERIMETER: 4.50 m

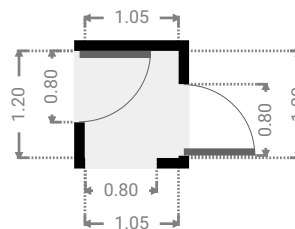

▼ **Hall**  
1st Floor

WIDTH: 0.90 m • LENGTH: 1.20 m  
AREA: 1.08 m<sup>2</sup> • PERIMETER: 4.21 m

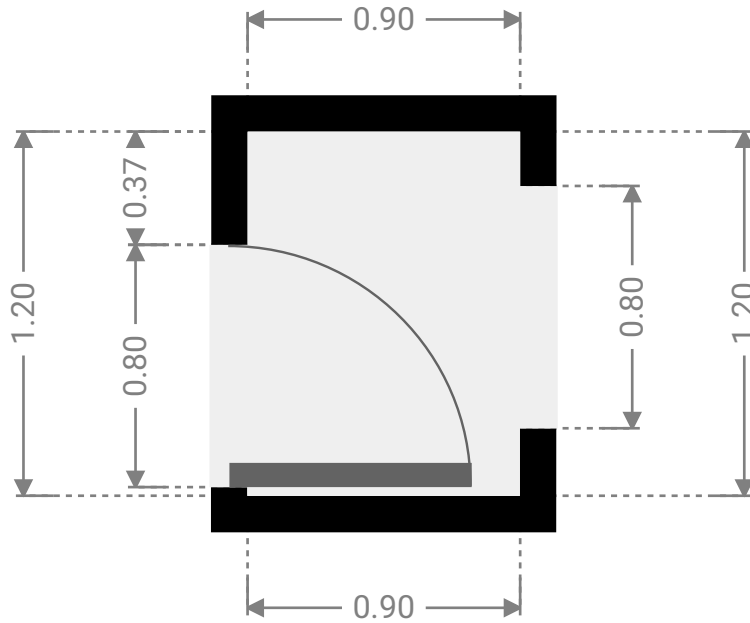
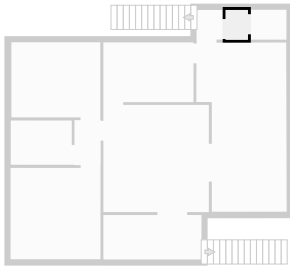

▼ **Toilet**  
1st Floor

WIDTH: 1.44 m • LENGTH: 1.21 m  
AREA: 1.74 m<sup>2</sup> • PERIMETER: 5.29 m

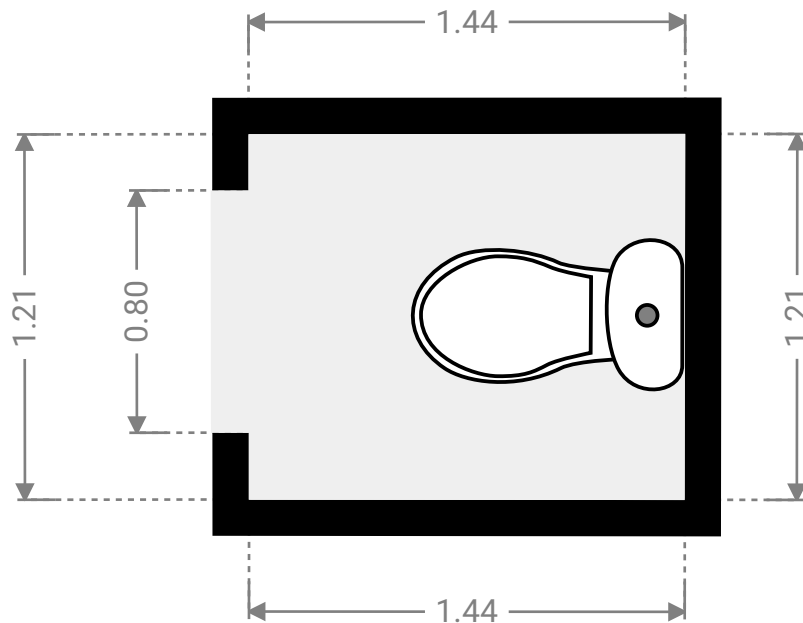
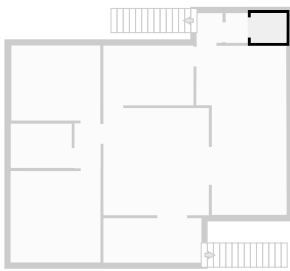

▼ **Bedroom**  
1st Floor

WIDTH: 3.65 m • LENGTH: 2.42 m  
AREA: 8.83 m<sup>2</sup> • PERIMETER: 12.14 m

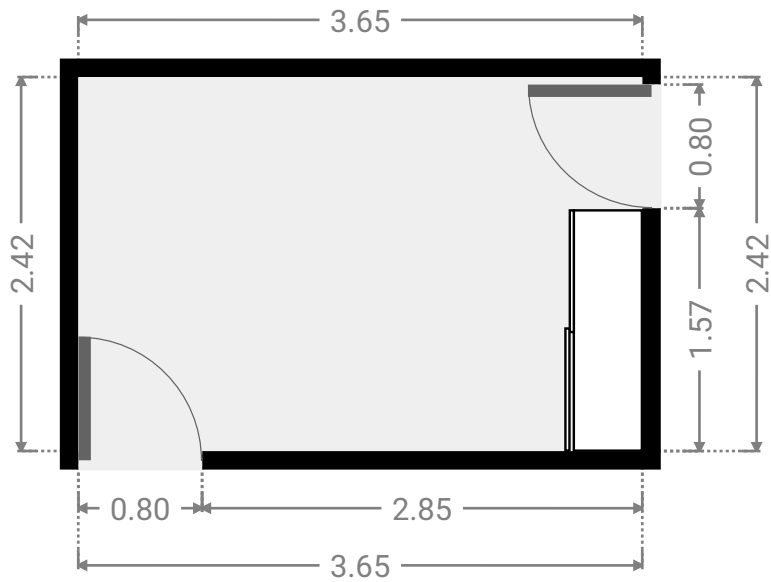
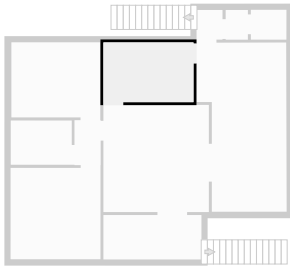

▼ **Hall**  
1st Floor

WIDTH: 1.06 m • LENGTH: 1.82 m  
AREA: 1.93 m<sup>2</sup> • PERIMETER: 5.76 m

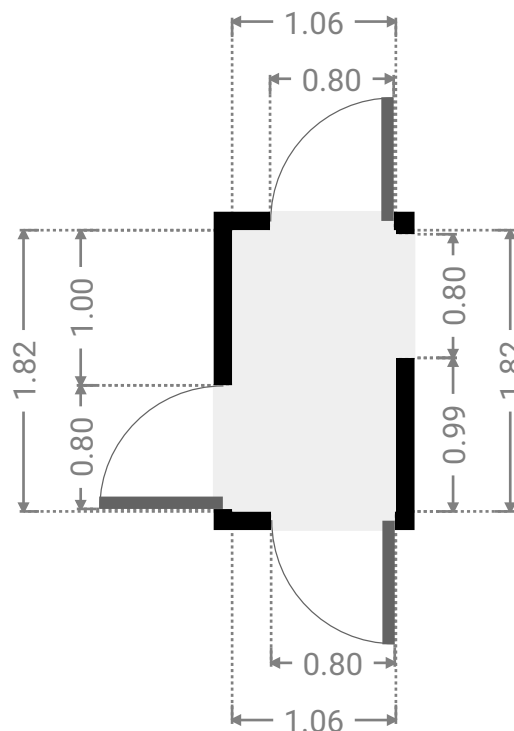
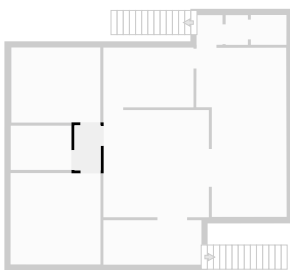



▼ **Bedroom**  
1st Floor

WIDTH: 3.60 m • LENGTH: 3.04 m  
AREA: 10.94 m<sup>2</sup> • PERIMETER: 13.28 m

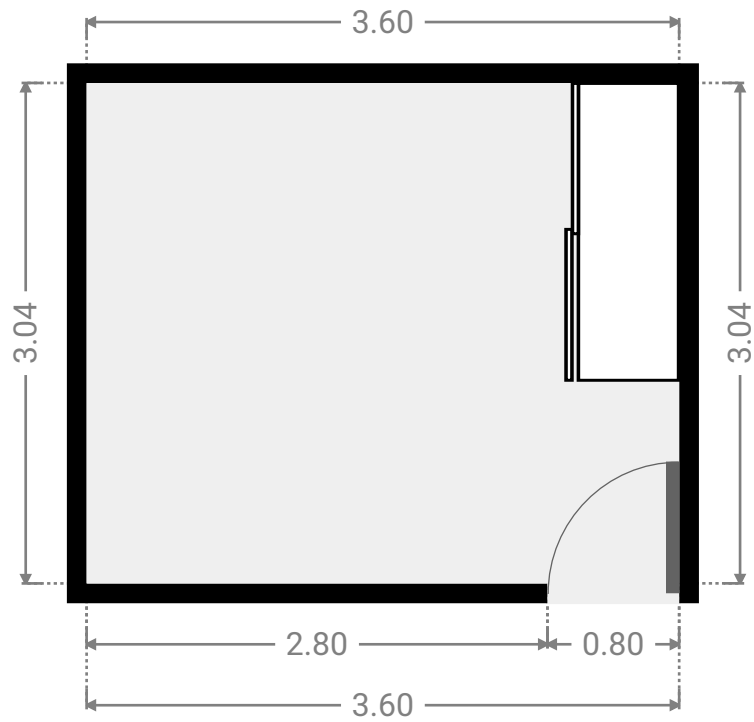
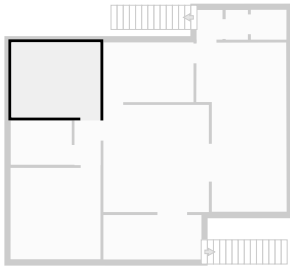

▼ **Bathroom**  
1st Floor

WIDTH: 2.47 m • LENGTH: 1.79 m  
AREA: 4.42 m<sup>2</sup> • PERIMETER: 8.52 m

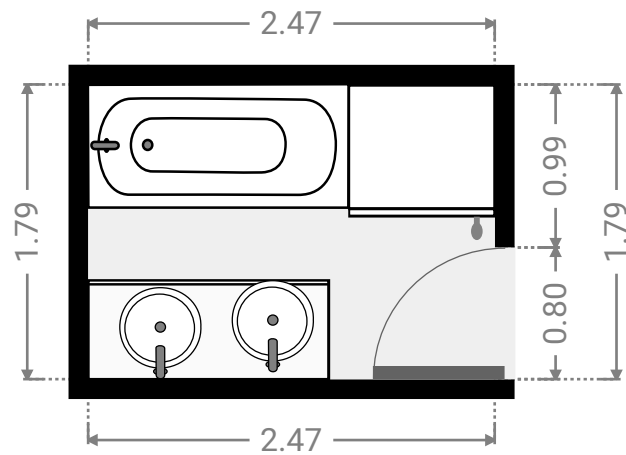
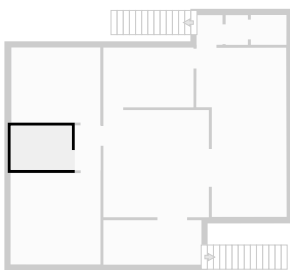

▼ **Master Bedroom**  
1st Floor

WIDTH: 3.64 m • LENGTH: 3.70 m  
AREA: 13.47 m<sup>2</sup> • PERIMETER: 14.68 m

