

202 McCullough Street

Ground Floor

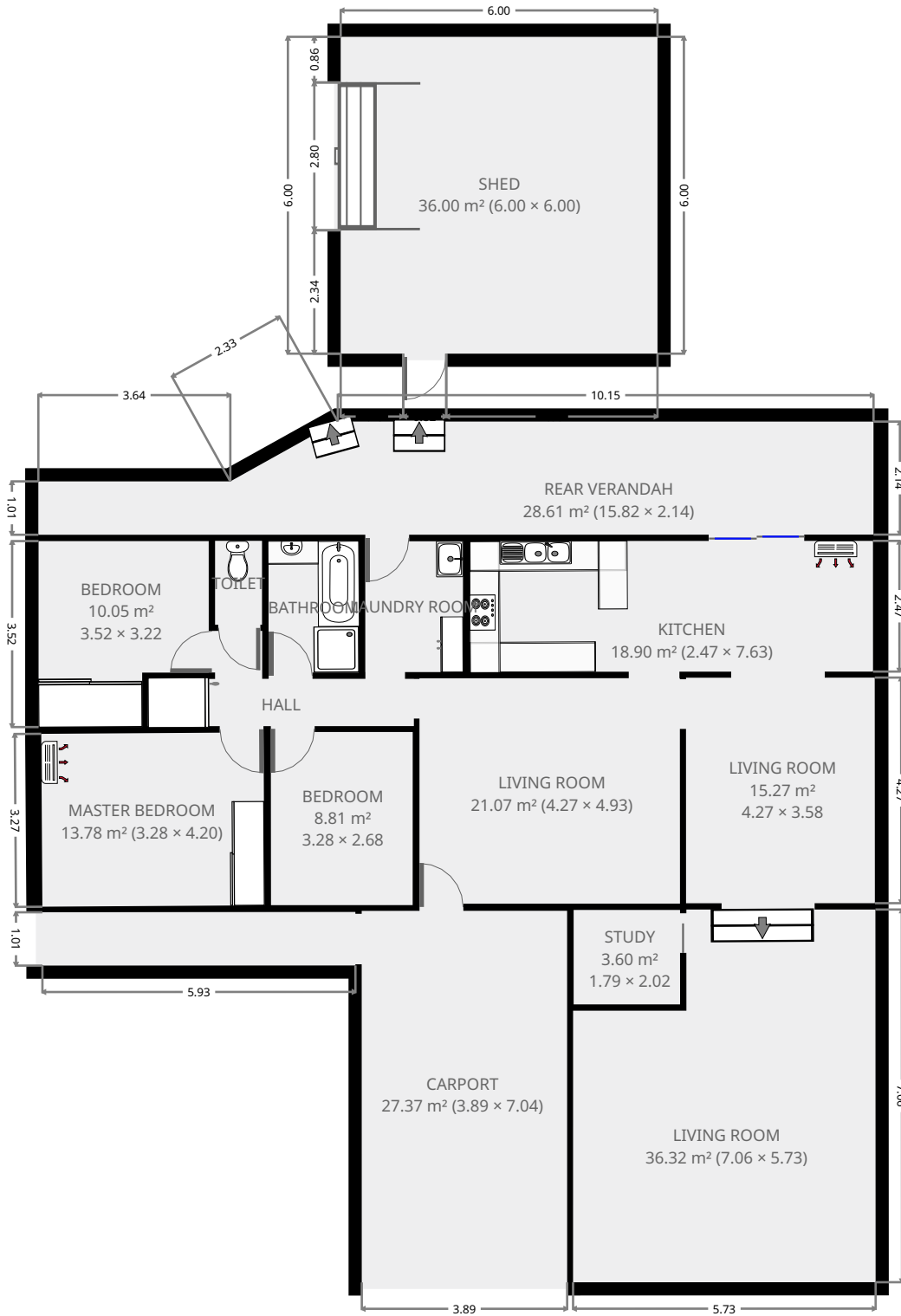

THIS FLOORPLAN IS PROVIDED WITHOUT WARRANTY OF ANY KIND. SENSOPIA DISCLAIMS ANY WARRANTY INCLUDING, WITHOUT LIMITATION, SATISFACTORY QUALITY OR ACCURACY OF DIMENSIONS.



202 McCullough Street

Living Room

Width: 4.27 m
 Length: 4.93 m
 Area: 21.07 m²
 Perimeter: 18.41 m

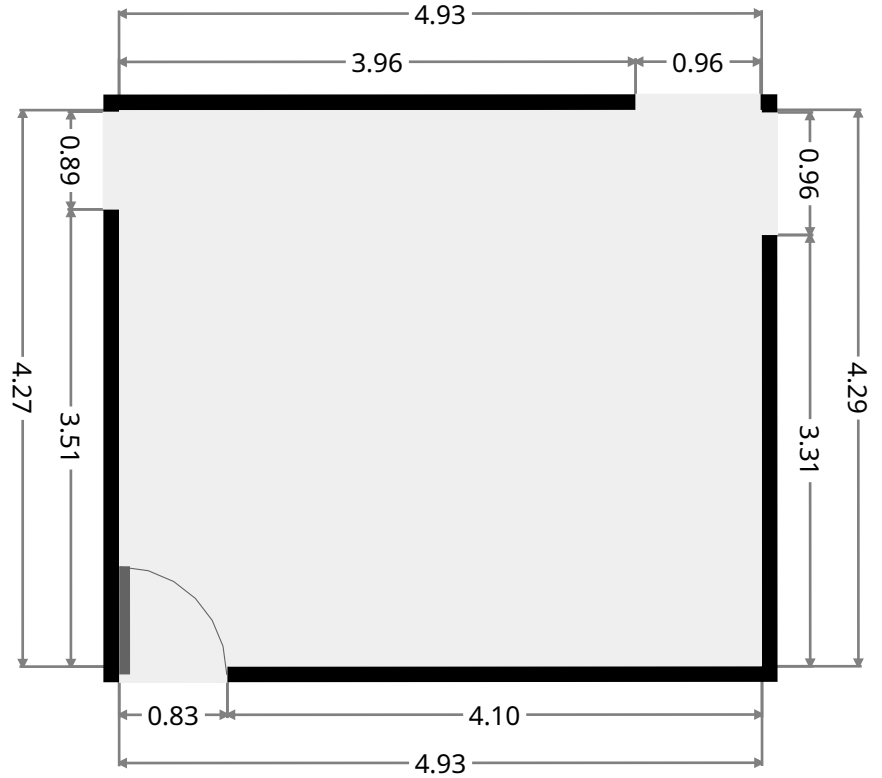
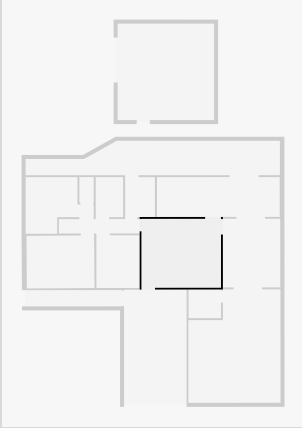

Hall

Width: 1.80 m
 Length: 5.05 m
 Area: 5.33 m²
 Perimeter: 13.69 m

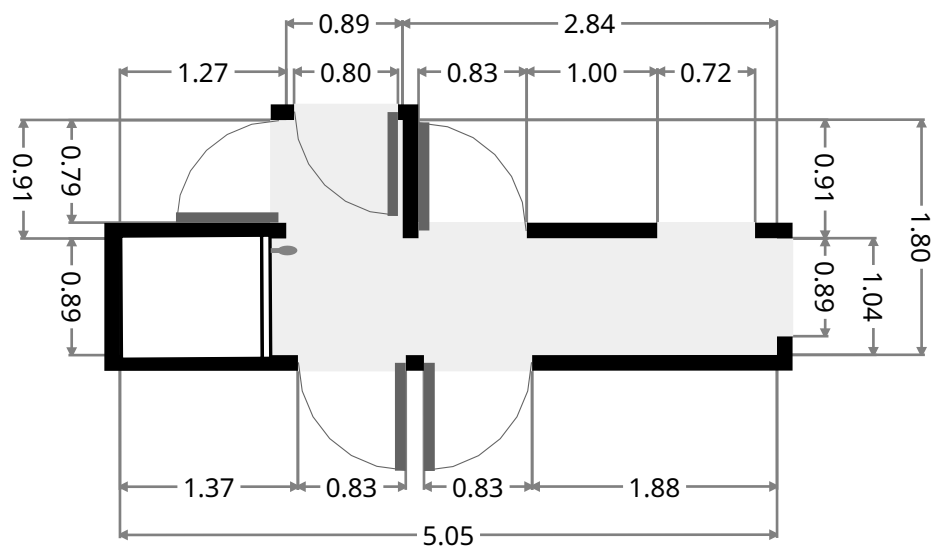
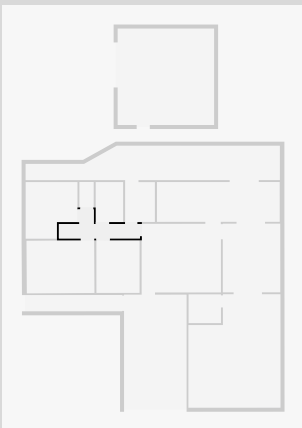

THIS FLOORPLAN IS PROVIDED WITHOUT WARRANTY OF ANY KIND. SENSOPIA DISCLAIMS ANY WARRANTY INCLUDING, WITHOUT LIMITATION, SATISFACTORY QUALITY OR ACCURACY OF DIMENSIONS.

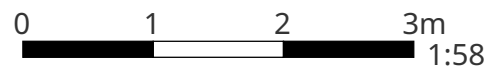

202 McCullough Street

Toilet

Width: 0.89 m
Length: 1.59 m
Area: 1.41 m²
Perimeter: 4.96 m

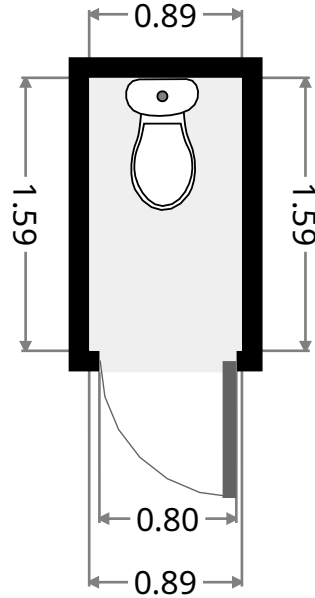
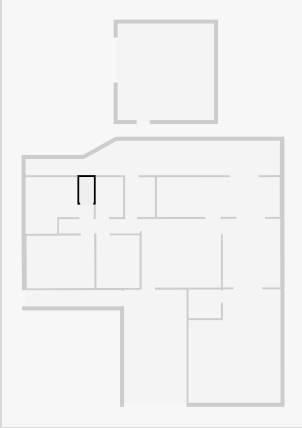

Bedroom

Width: 3.22 m
Length: 3.52 m
Area: 10.05 m²
Perimeter: 13.49 m

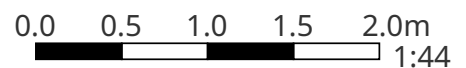
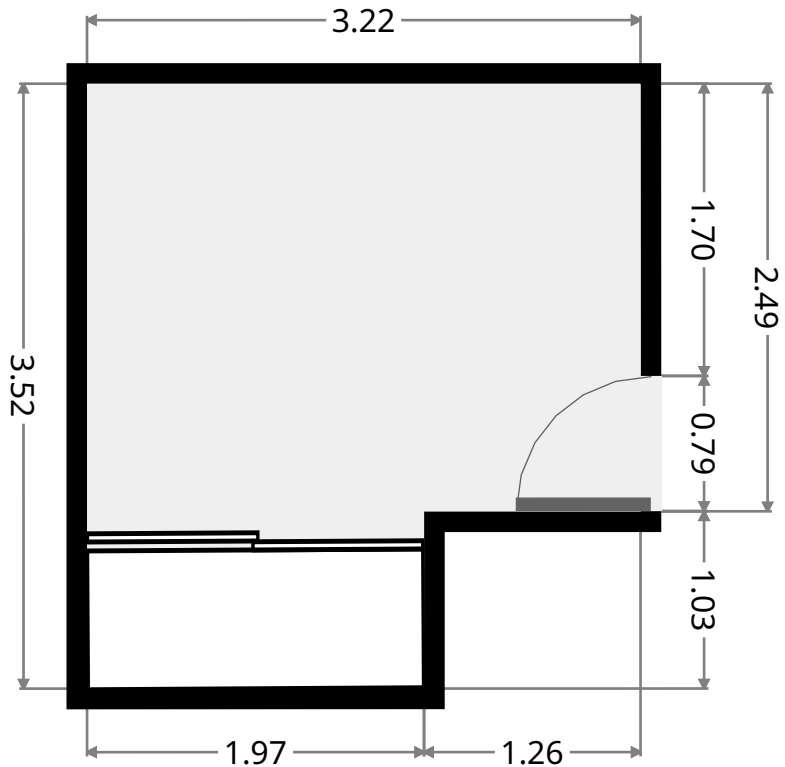
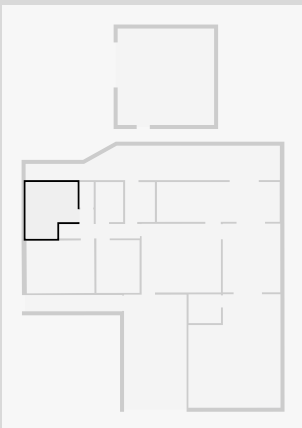

THIS FLOORPLAN IS PROVIDED WITHOUT WARRANTY OF ANY KIND. SENSOPIA DISCLAIMS ANY WARRANTY INCLUDING, WITHOUT LIMITATION, SATISFACTORY QUALITY OR ACCURACY OF DIMENSIONS.

202 McCullough Street

Master Bedroom

Width: 3.28 m
 Length: 4.20 m
 Area: 13.78 m²
 Perimeter: 14.97 m

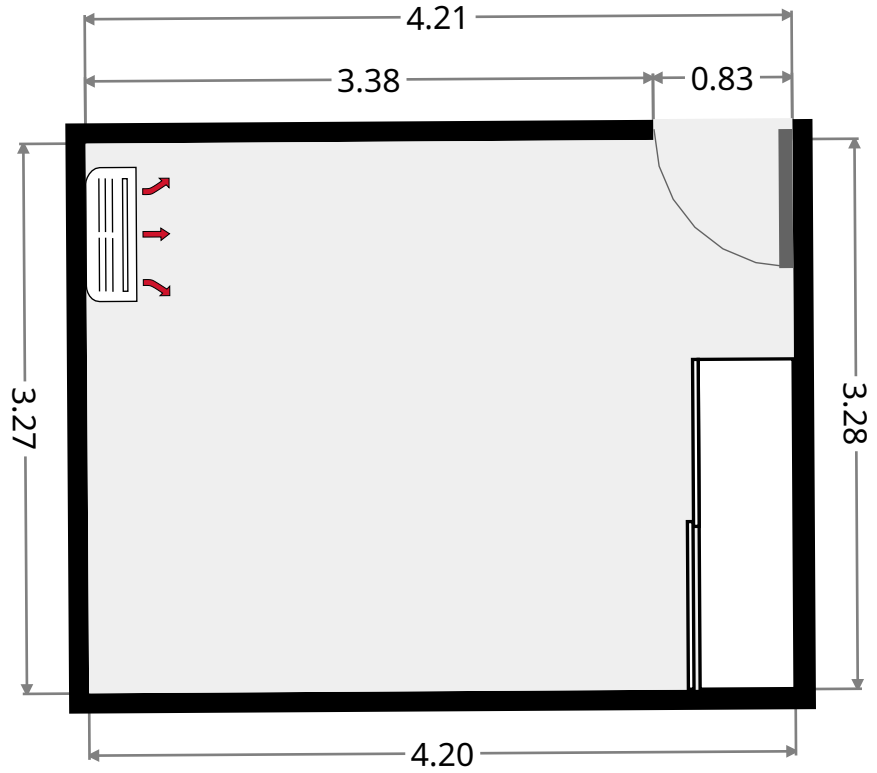
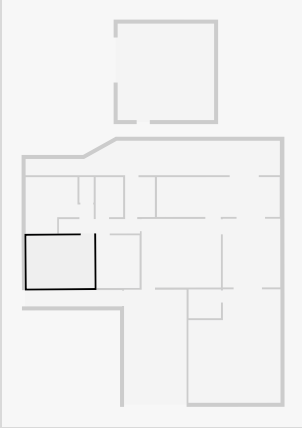

Bedroom

Width: 2.68 m
 Length: 3.28 m
 Area: 8.81 m²
 Perimeter: 11.93 m

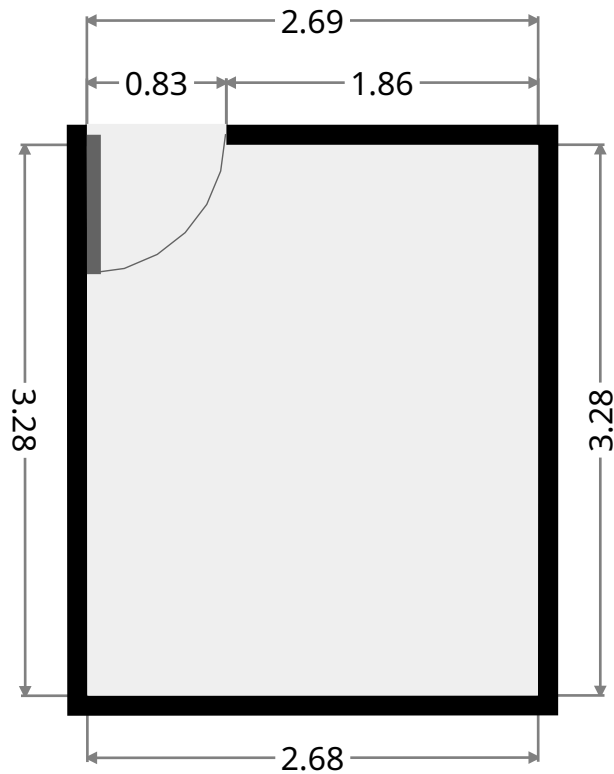
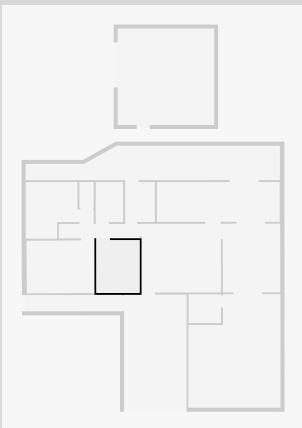

THIS FLOORPLAN IS PROVIDED WITHOUT WARRANTY OF ANY KIND. SENSOPIA DISCLAIMS ANY WARRANTY INCLUDING, WITHOUT LIMITATION, SATISFACTORY QUALITY OR ACCURACY OF DIMENSIONS.

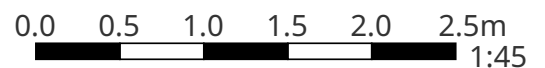

202 McCullough Street

Bathroom

Width: 1.71 m
Length: 2.49 m
Area: 4.25 m²
Perimeter: 8.39 m

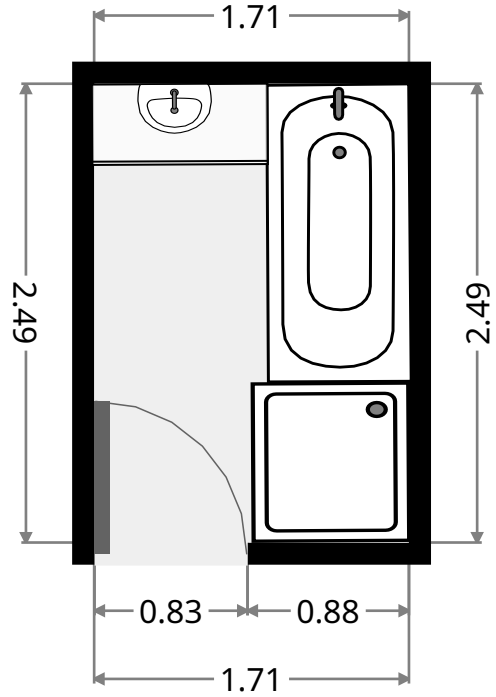
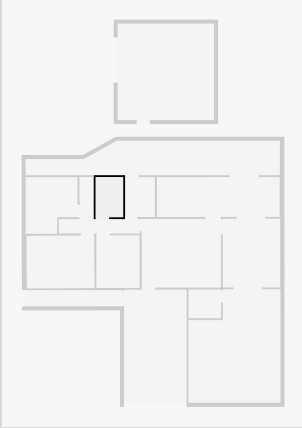

Laundry Room

Width: 1.85 m
Length: 2.48 m
Area: 4.58 m²
Perimeter: 8.65 m

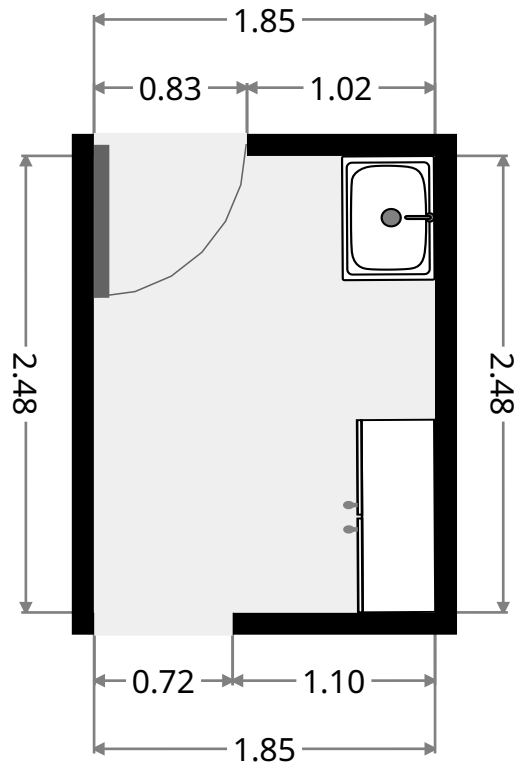
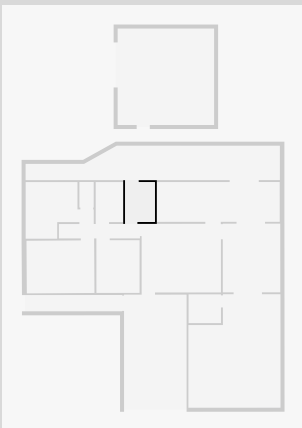

202 McCullough Street

Kitchen

Width: 2.47 m
 Length: 7.63 m
 Area: 18.90 m²
 Perimeter: 20.23 m

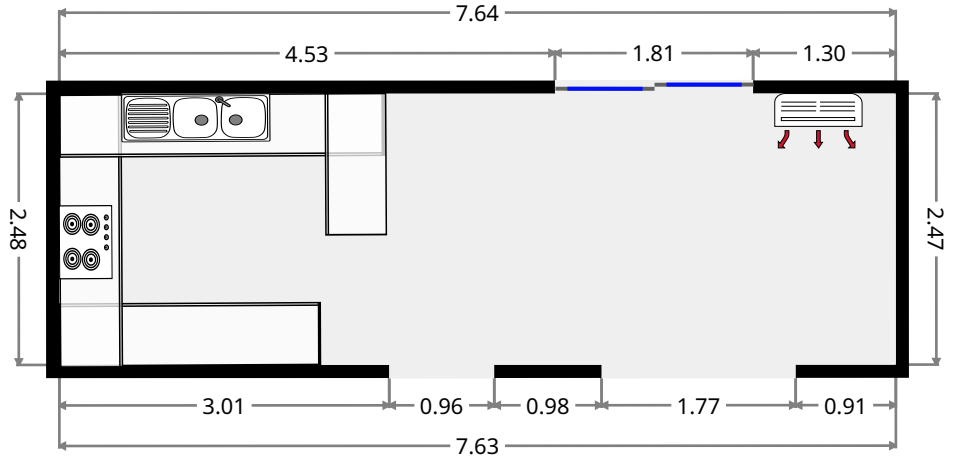
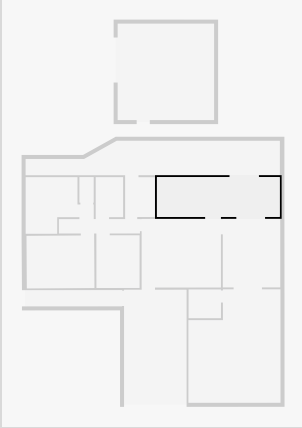

Living Room

Width: 3.58 m
 Length: 4.27 m
 Area: 15.27 m²
 Perimeter: 15.70 m

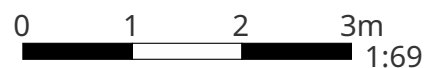
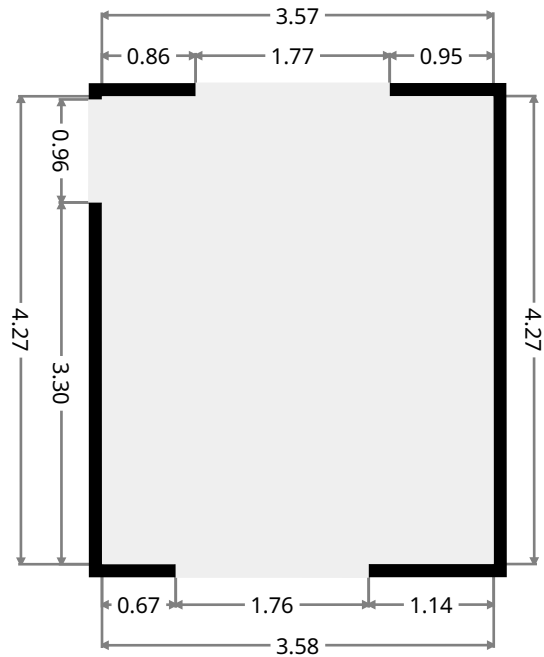
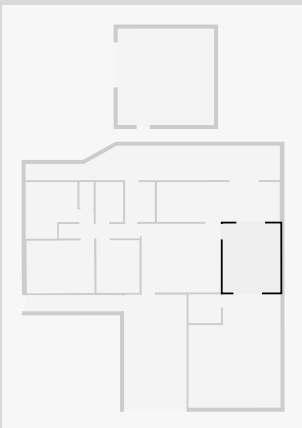

THIS FLOORPLAN IS PROVIDED WITHOUT WARRANTY OF ANY KIND. SENSOPIA DISCLAIMS ANY WARRANTY INCLUDING, WITHOUT LIMITATION, SATISFACTORY QUALITY OR ACCURACY OF DIMENSIONS.

202 McCullough Street

Living Room

Width: 5.73 m
 Length: 7.06 m
 Area: 36.32 m²
 Perimeter: 25.57 m

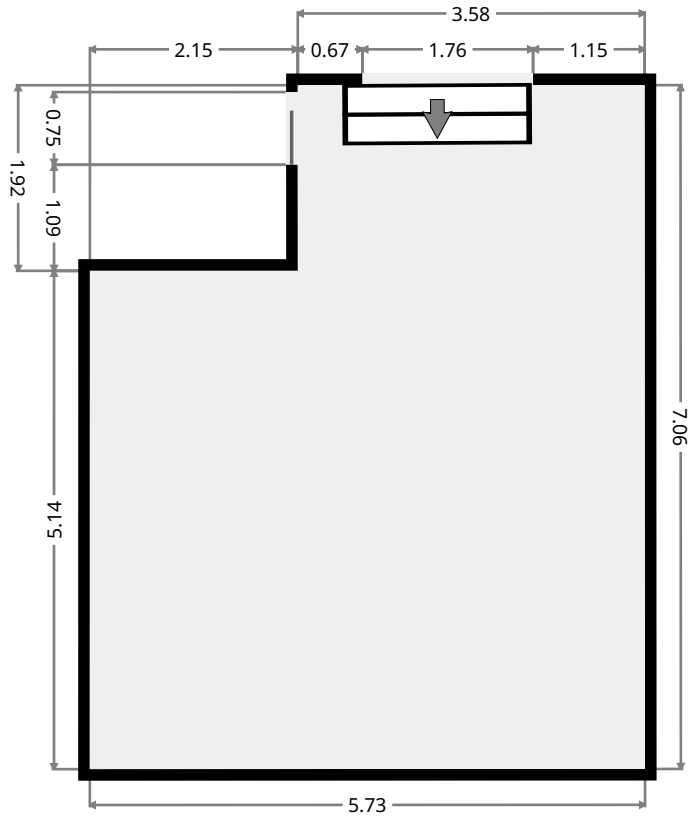
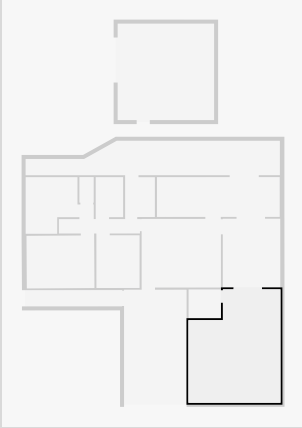

Study

Width: 1.79 m
 Length: 2.02 m
 Area: 3.60 m²
 Perimeter: 7.61 m

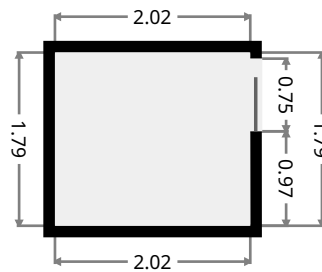
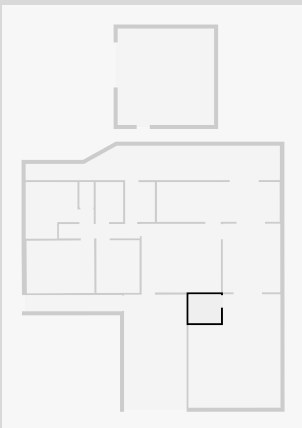

202 McCullough Street

Carport

Width: 3.89 m
 Length: 7.04 m
 Area: 27.37 m²
 Perimeter: 21.85 m

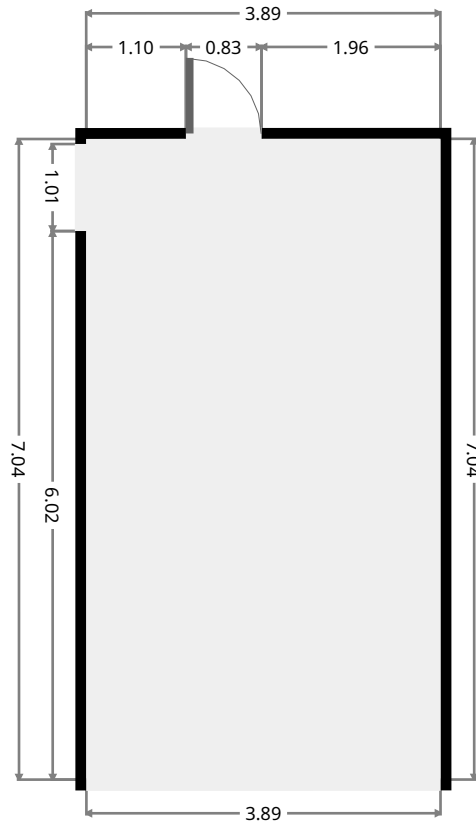
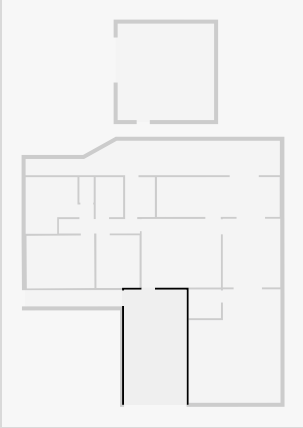

Width: 1.01 m
 Length: 5.93 m
 Area: 6.00 m²
 Perimeter: 13.88 m

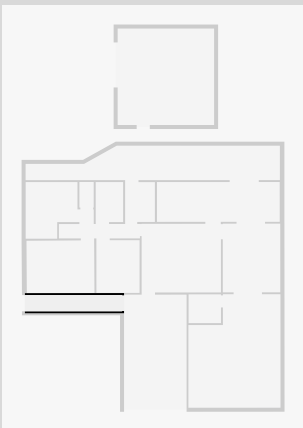

202 McCullough Street

Rear Verandah

Width: 2.14 m
Length: 15.82 m
Area: 28.61 m²
Perimeter: 35.08 m

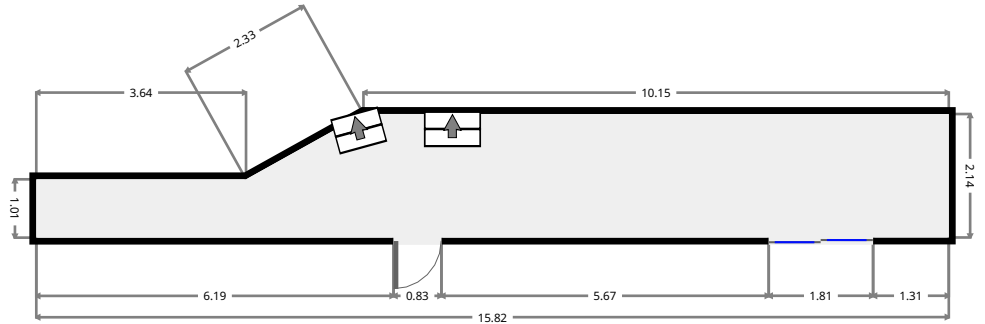
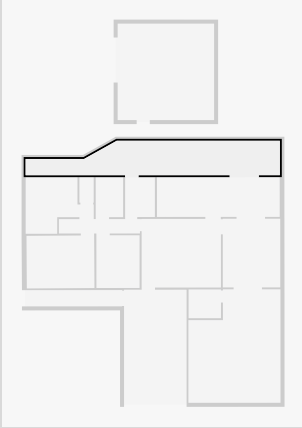

202 McCullough Street

Shed

Width: 6.00 m
Length: 6.00 m
Area: 36.00 m²
Perimeter: 24.00 m

