

# 202 High Street

**SUBMITTED BY**  
Ray White Rockhampton Casey  
stockers@cqoz.com

---

**CREATED ON**  
2022-12-05

---

**Floors**  
2

---

▼ Ground Floor

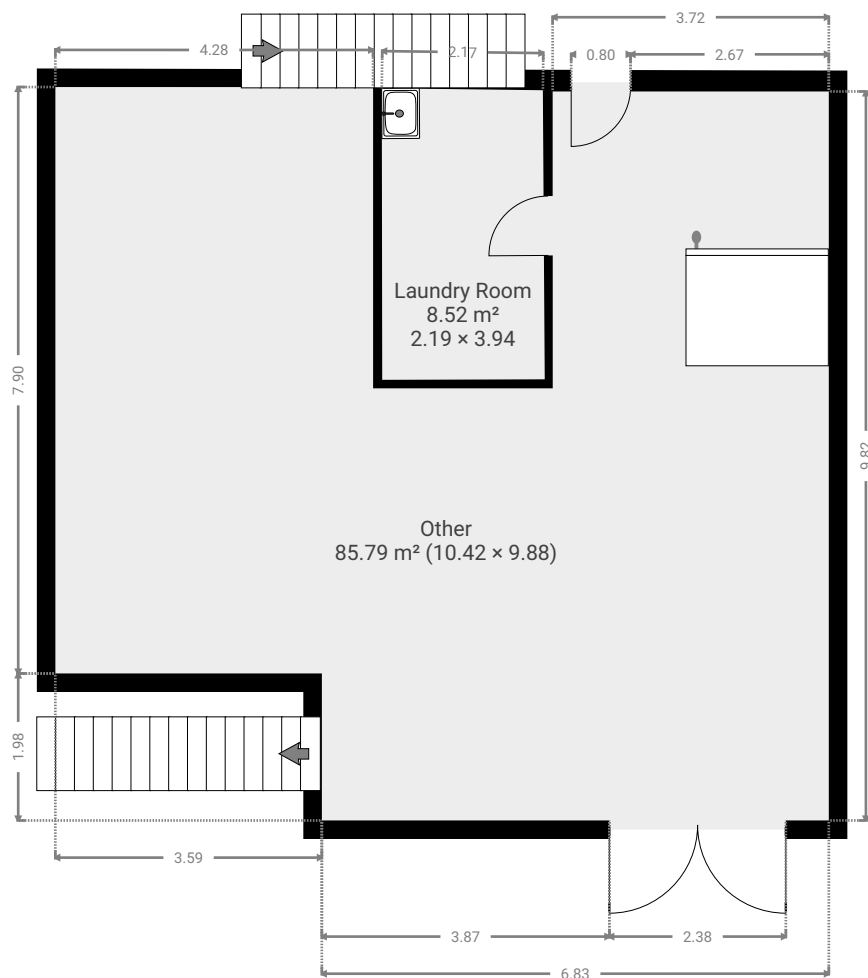
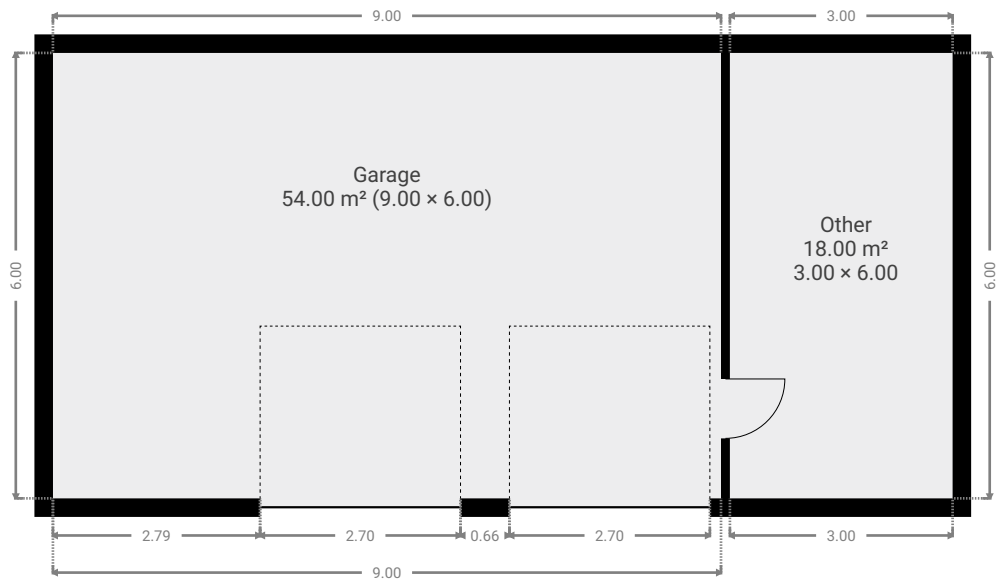

▼ **Garage**  
Ground Floor

WIDTH: 9.00 m • LENGTH: 6.00 m  
AREA: 54.00 m<sup>2</sup> • PERIMETER: 30.00 m

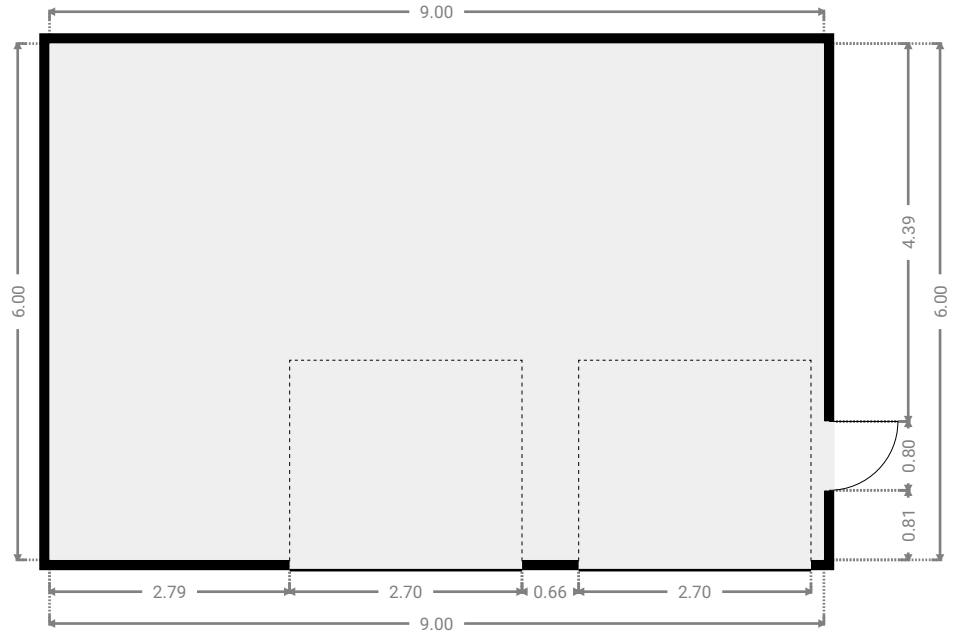
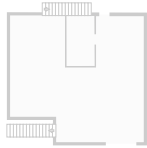

▼ **Laundry Room**  
Ground Floor

WIDTH: 2.19 m • LENGTH: 3.94 m  
AREA: 8.52 m<sup>2</sup> • PERIMETER: 12.18 m

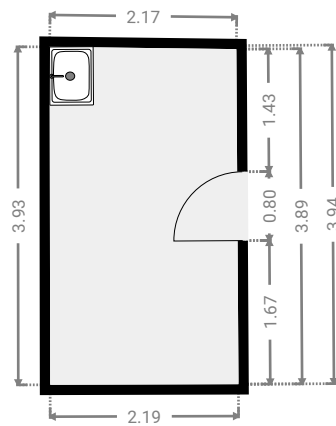
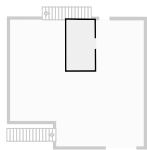

▼ Other  
Ground Floor

WIDTH: 10.42 m • LENGTH: 9.88 m  
AREA: 85.79 m<sup>2</sup> • PERIMETER: 48.60 m

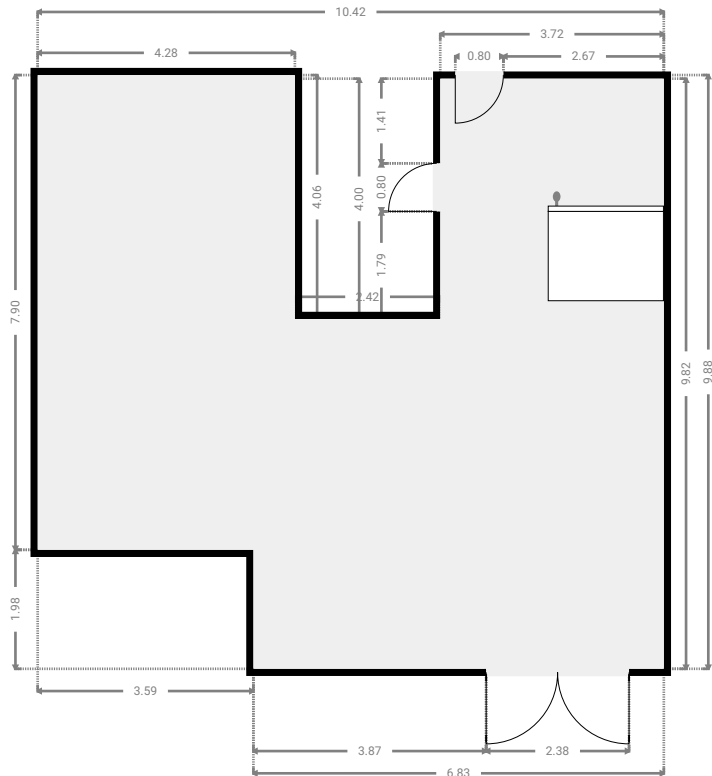
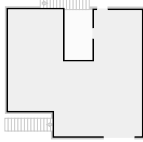

▼ Other  
Ground Floor

WIDTH: 3.00 m • LENGTH: 6.00 m  
AREA: 18.00 m<sup>2</sup> • PERIMETER: 18.00 m

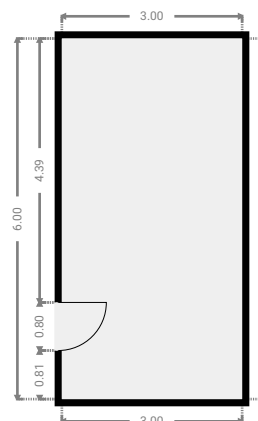
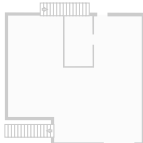

▼ 1st Floor

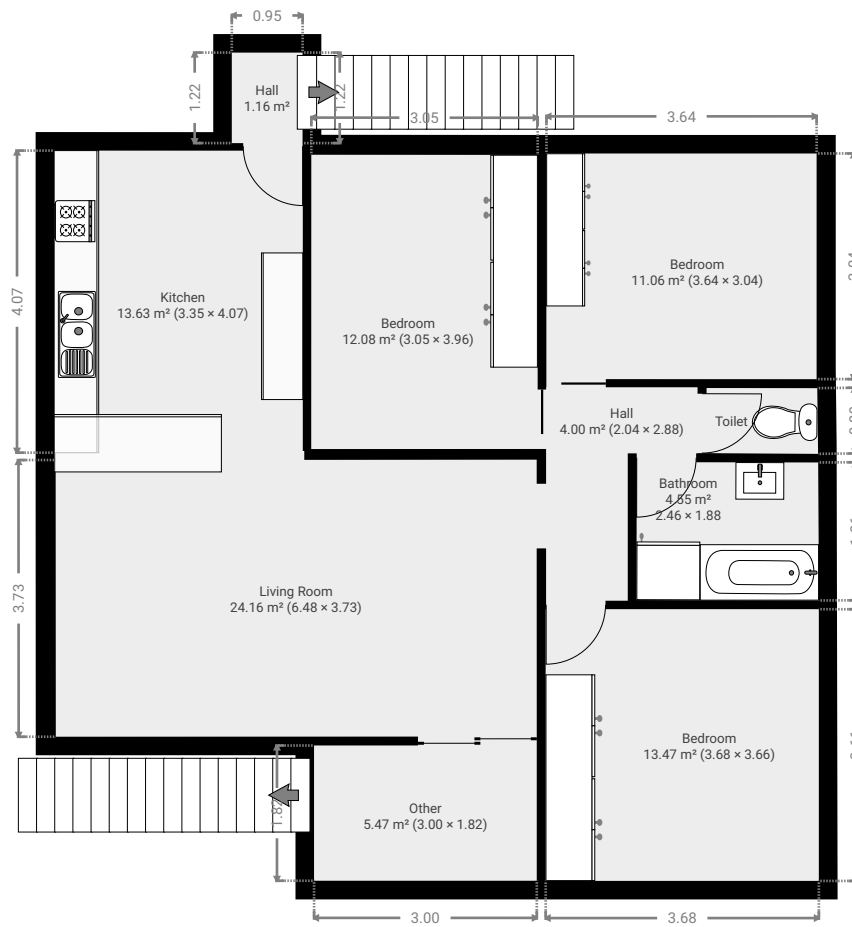

▼ **Bathroom**  
1st Floor

WIDTH: 2.46 m • LENGTH: 1.88 m  
AREA: 4.55 m<sup>2</sup> • PERIMETER: 8.62 m

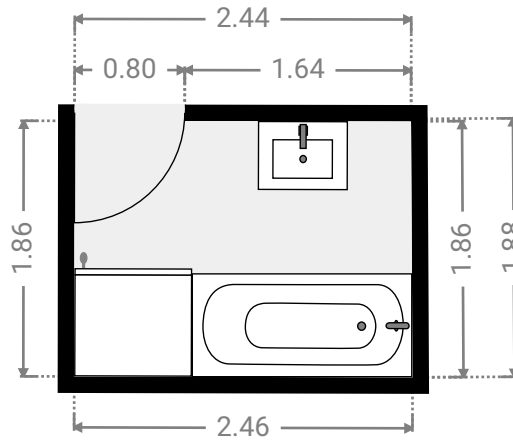
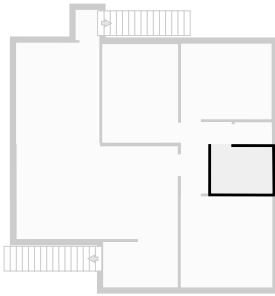

▼ **Bedroom**  
1st Floor

WIDTH: 3.05 m • LENGTH: 3.96 m  
AREA: 12.08 m<sup>2</sup> • PERIMETER: 14.02 m

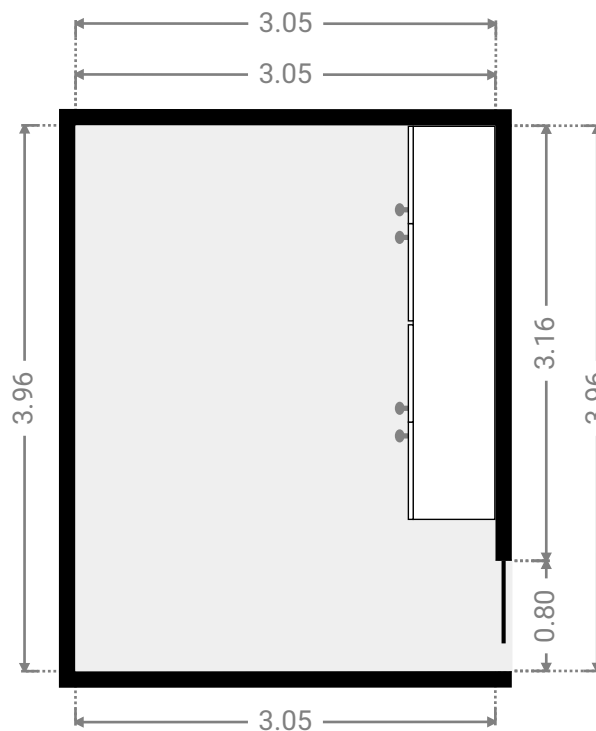
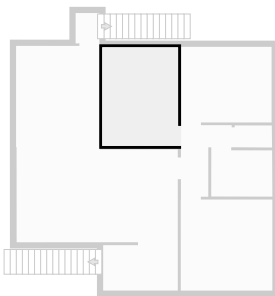

▼ **Bedroom**  
1st Floor

WIDTH: 3.64 m • LENGTH: 3.04 m  
AREA: 11.06 m<sup>2</sup> • PERIMETER: 13.36 m

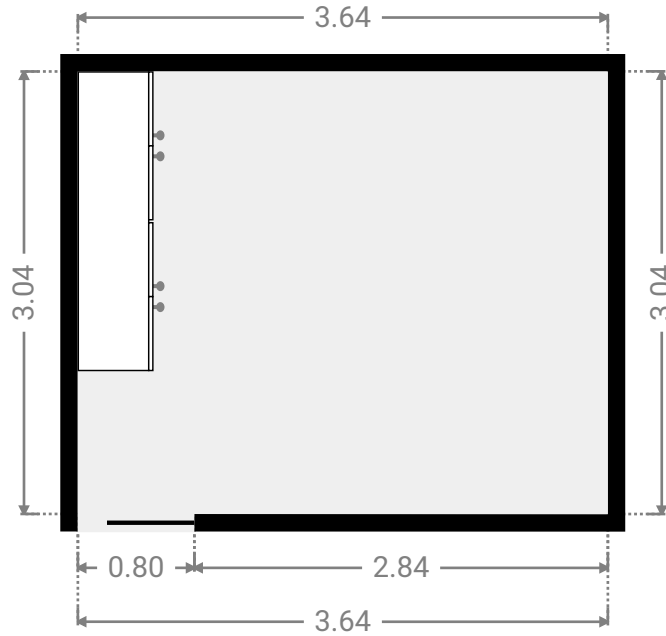
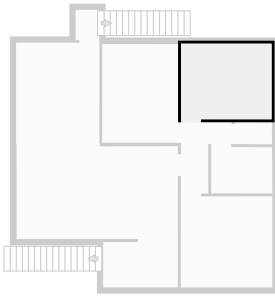

▼ **Bedroom**  
1st Floor

WIDTH: 3.68 m • LENGTH: 3.66 m  
AREA: 13.47 m<sup>2</sup> • PERIMETER: 14.68 m

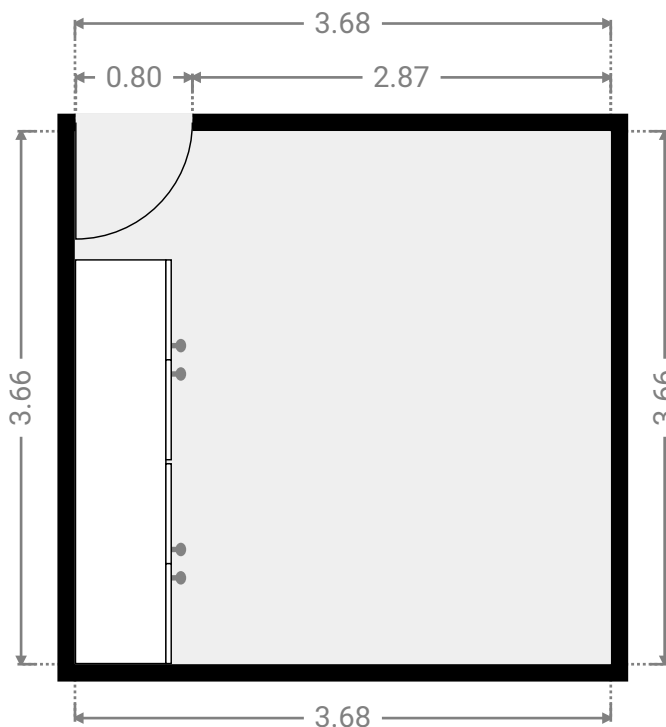
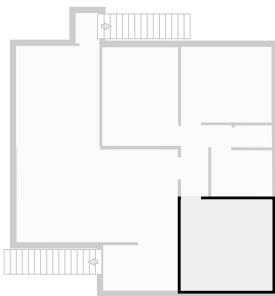

▼ **Hall**  
1st Floor

WIDTH: 0.95 m • LENGTH: 1.22 m  
AREA: 1.16 m<sup>2</sup> • PERIMETER: 4.35 m

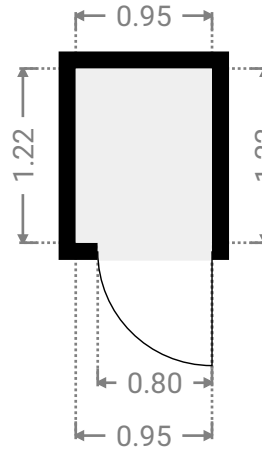
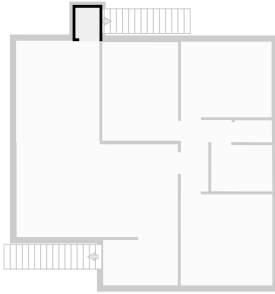

▼ **Hall**  
1st Floor

WIDTH: 2.04 m • LENGTH: 2.88 m  
AREA: 4.00 m<sup>2</sup> • PERIMETER: 9.83 m

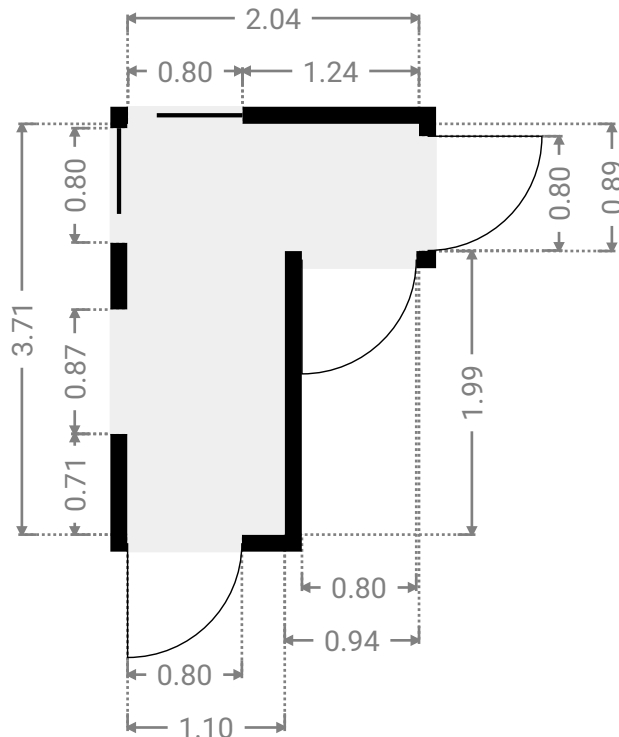
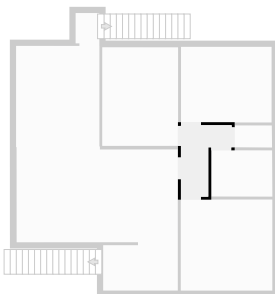



▼ **Kitchen**  
1st Floor

WIDTH: 3.35 m • LENGTH: 4.07 m  
AREA: 13.63 m<sup>2</sup> • PERIMETER: 14.84 m

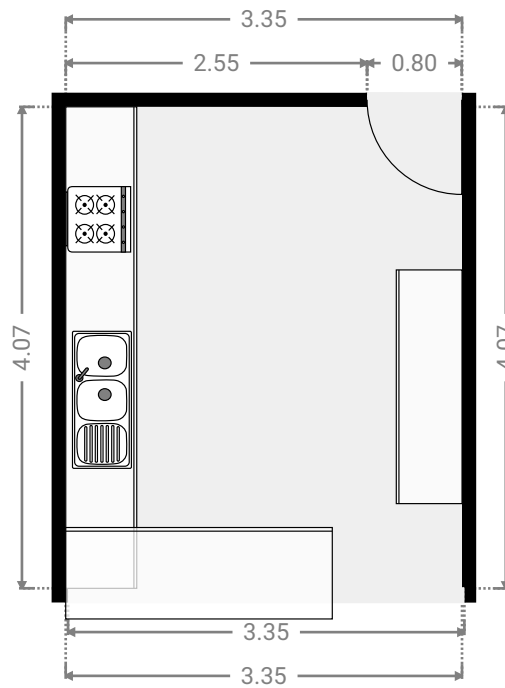
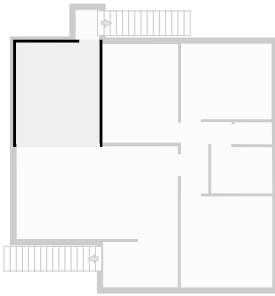

▼ **Living Room**  
1st Floor

WIDTH: 6.48 m • LENGTH: 3.73 m  
AREA: 24.16 m<sup>2</sup> • PERIMETER: 20.42 m

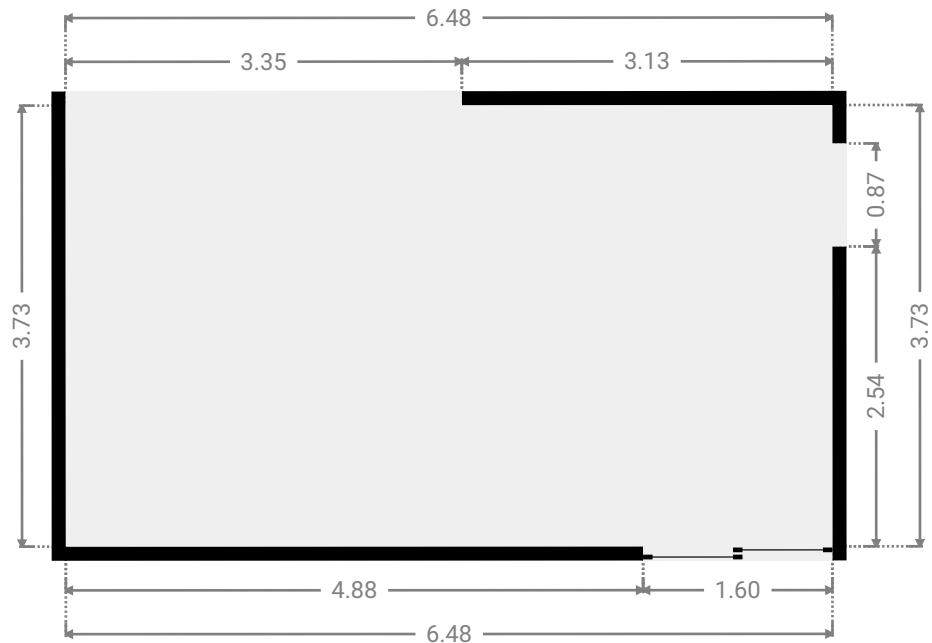
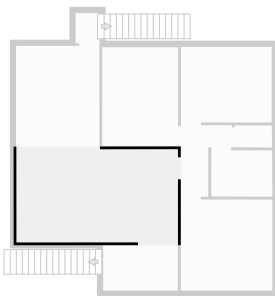

▼ **Other**  
1st Floor

WIDTH: 3.00 m • LENGTH: 1.82 m  
AREA: 5.47 m<sup>2</sup> • PERIMETER: 9.64 m

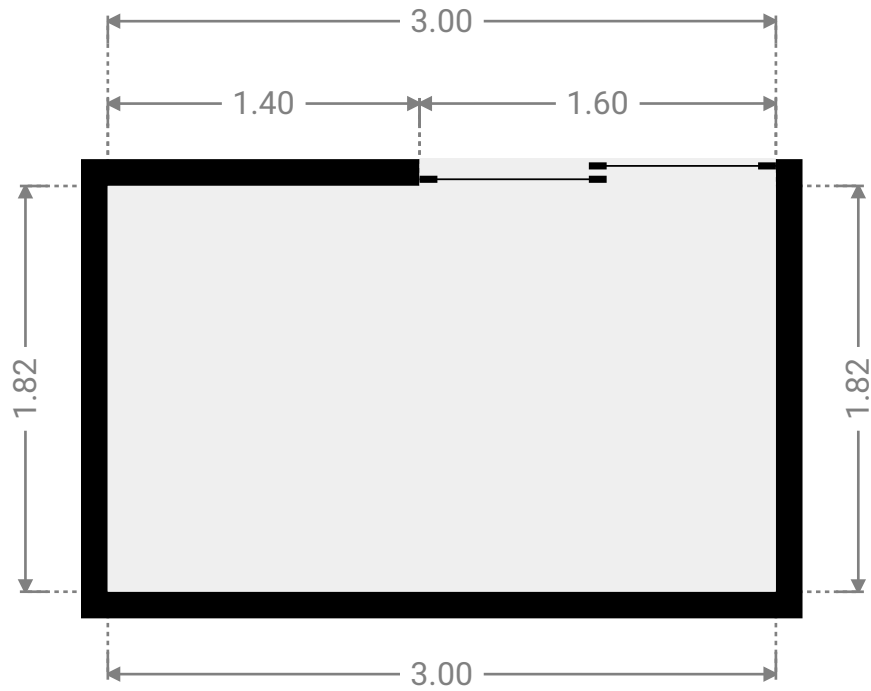
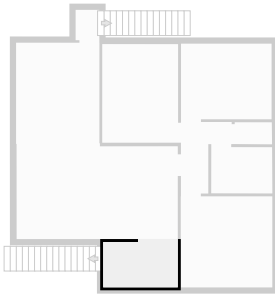

▼ **Toilet**  
1st Floor

WIDTH: 1.51 m • LENGTH: 0.88 m  
AREA: 1.32 m<sup>2</sup> • PERIMETER: 4.76 m

