

20 Tamarind Avenue

SUBMITTED BY
Ray White Rockhampton Casey
stockers@cqoz.com

CREATED ON
2017-03-16

Floors
1

▼ Ground Floor



FLOORS: 1

▼ .
Ground Floor

WIDTH: 1.61 m • LENGTH: 2.84 m
AREA: 4.26 m² • PERIMETER: 8.90 m

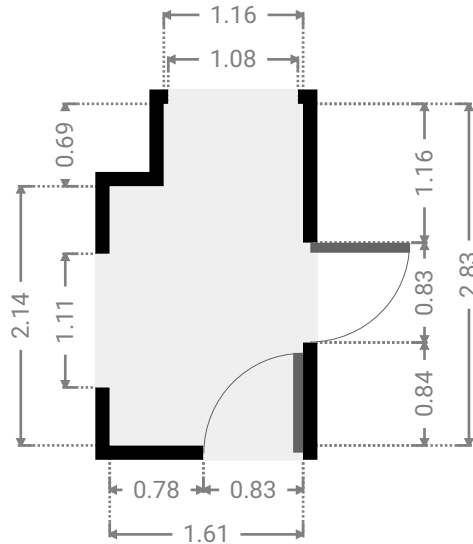
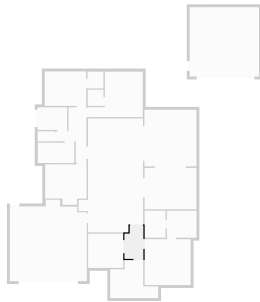

▼ Alfresco
Ground Floor

WIDTH: 4.50 m • LENGTH: 4.90 m
AREA: 22.04 m² • PERIMETER: 18.80 m

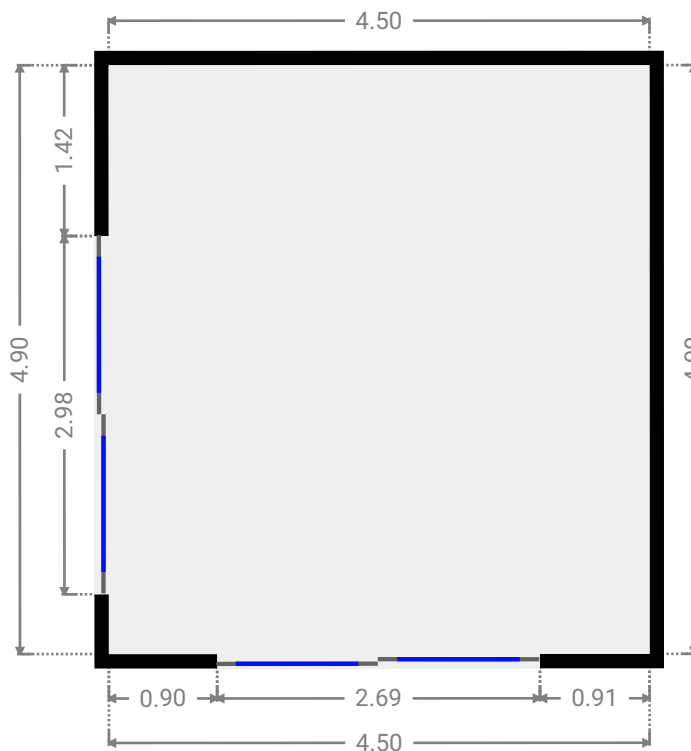
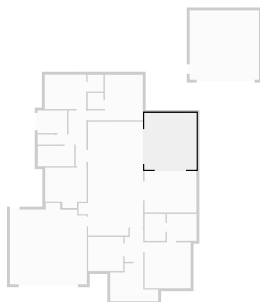

FLOORS: 1

▼ Bathroom
Ground Floor

WIDTH: 2.56 m • LENGTH: 2.33 m
AREA: 5.98 m² • PERIMETER: 9.79 m

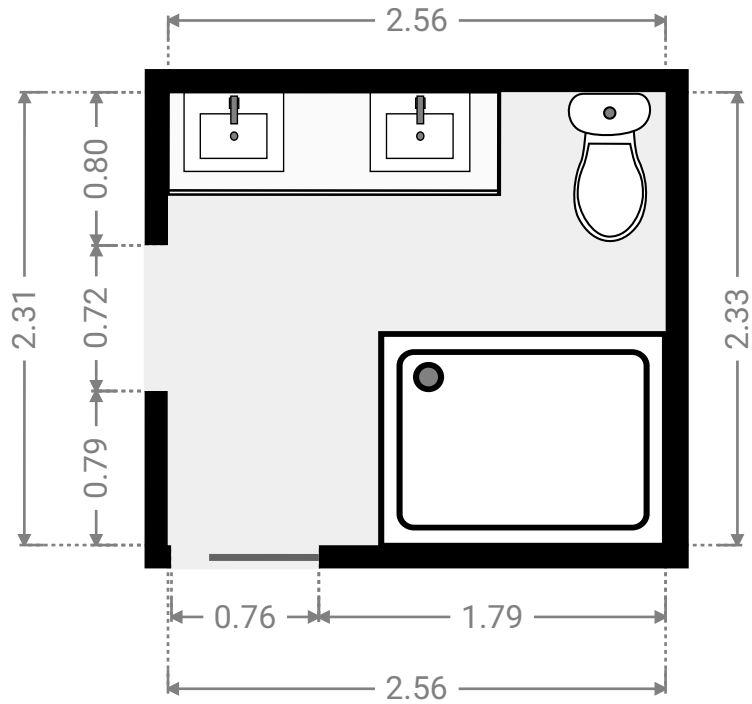
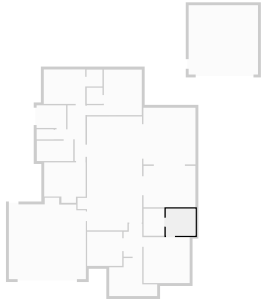

▼ WIR
Ground Floor

WIDTH: 1.81 m • LENGTH: 2.34 m
AREA: 4.23 m² • PERIMETER: 8.29 m

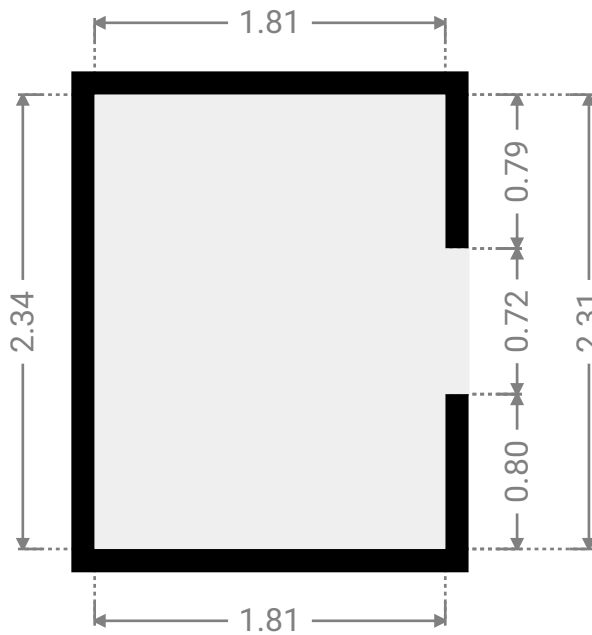
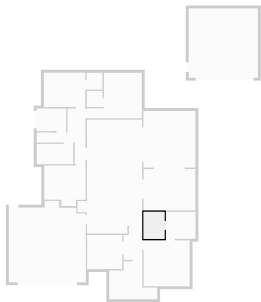

FLOORS: 1

▼ Bathroom
Ground Floor

WIDTH: 3.15 m • LENGTH: 1.76 m
AREA: 5.54 m² • PERIMETER: 9.82 m

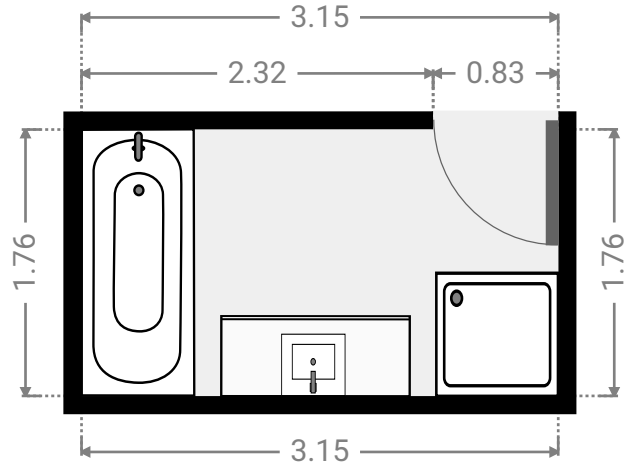
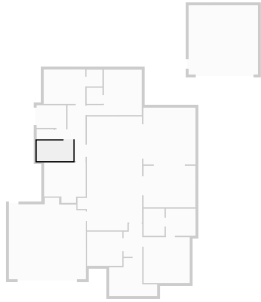

▼ Bedroom
Ground Floor

WIDTH: 3.58 m • LENGTH: 3.50 m
AREA: 11.27 m² • PERIMETER: 14.16 m

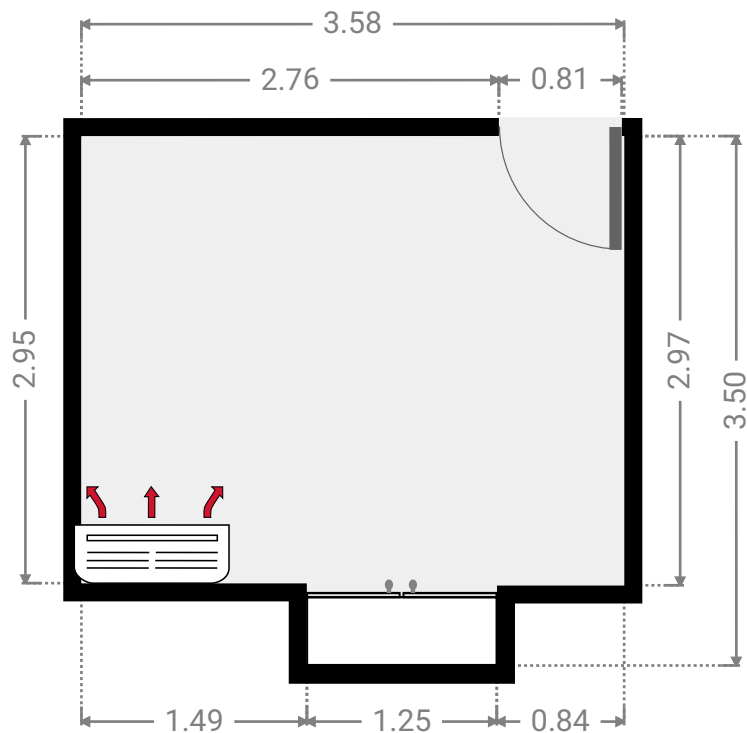
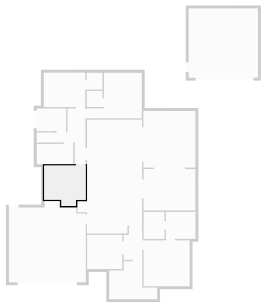

FLOORS: 1

▼ **Bedroom**
Ground Floor

WIDTH: 3.59 m • LENGTH: 2.98 m
AREA: 10.68 m² • PERIMETER: 13.13 m

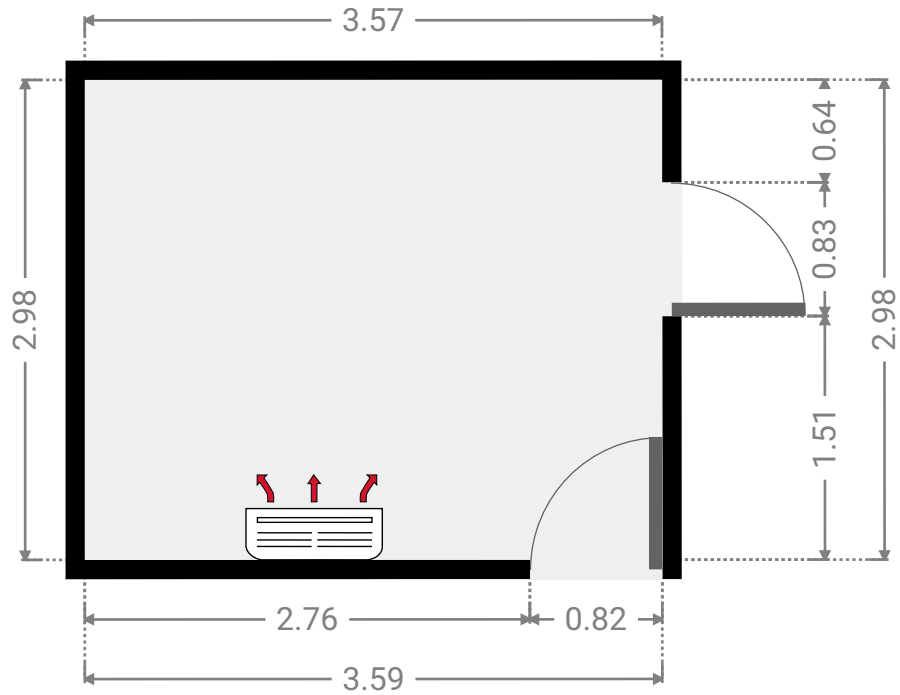
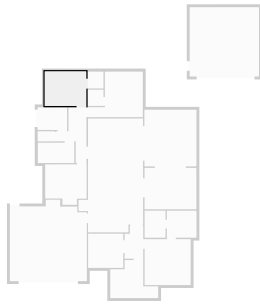

▼ **WIR**
Ground Floor

WIDTH: 1.37 m • LENGTH: 1.45 m
AREA: 1.99 m² • PERIMETER: 5.65 m

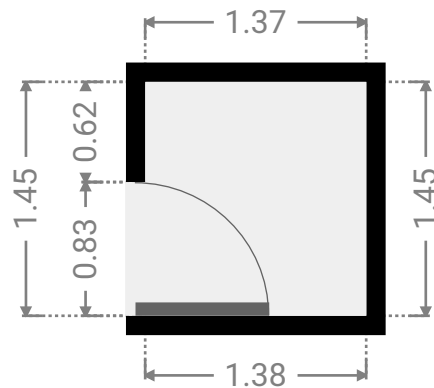
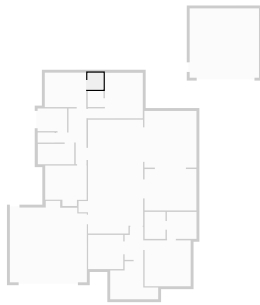

FLOORS: 1

▼ **Bedroom**
Ground Floor

WIDTH: 4.75 m • LENGTH: 3.93 m
AREA: 14.18 m² • PERIMETER: 17.38 m

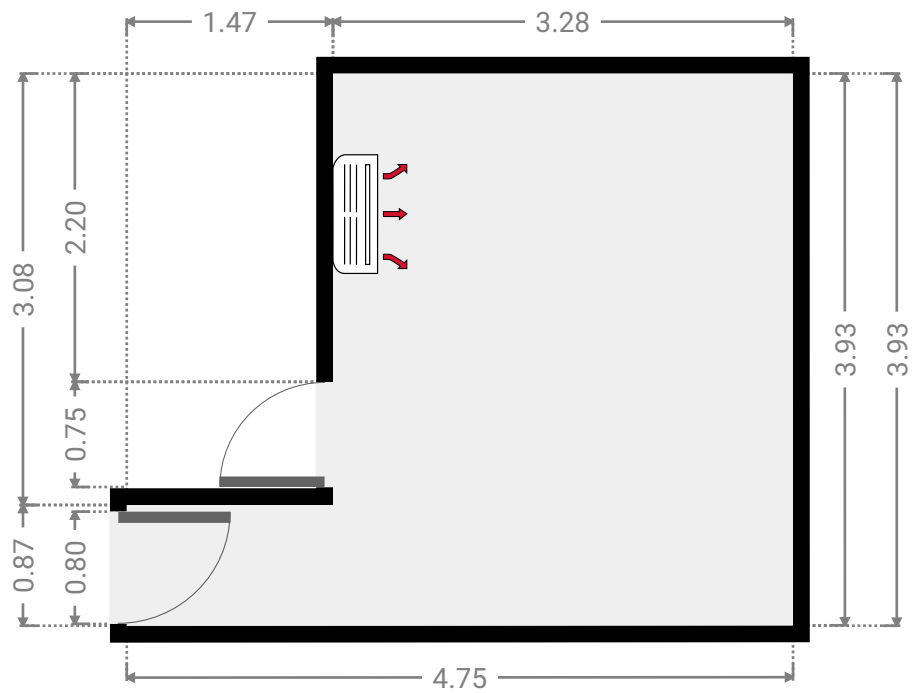
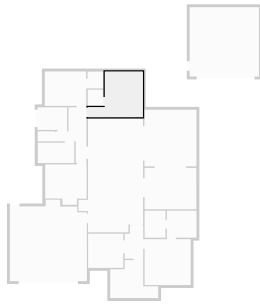

▼ **WIR**
Ground Floor

WIDTH: 1.36 m • LENGTH: 1.40 m
AREA: 1.91 m² • PERIMETER: 5.53 m

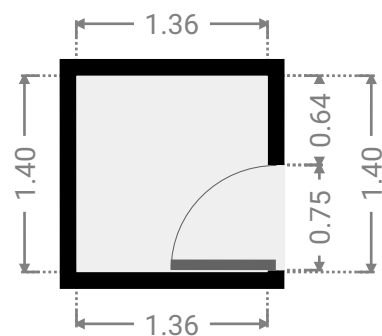
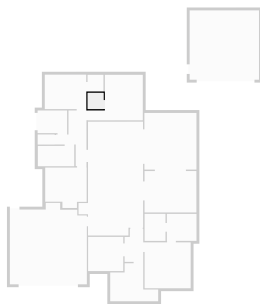

FLOORS: 1

▼ Foyer Ground Floor

WIDTH: 4.16 m • LENGTH: 3.29 m
AREA: 9.71 m² • PERIMETER: 14.87 m

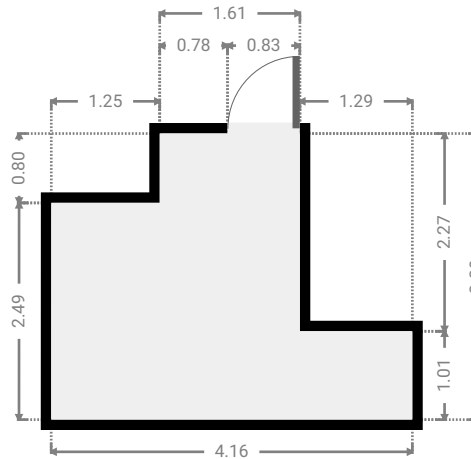
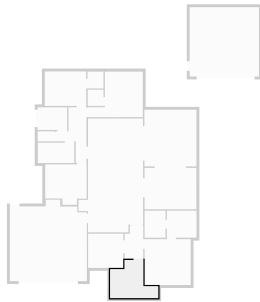

▼ Garage Ground Floor

WIDTH: 6.66 m • LENGTH: 7.05 m
AREA: 43.34 m² • PERIMETER: 27.41 m

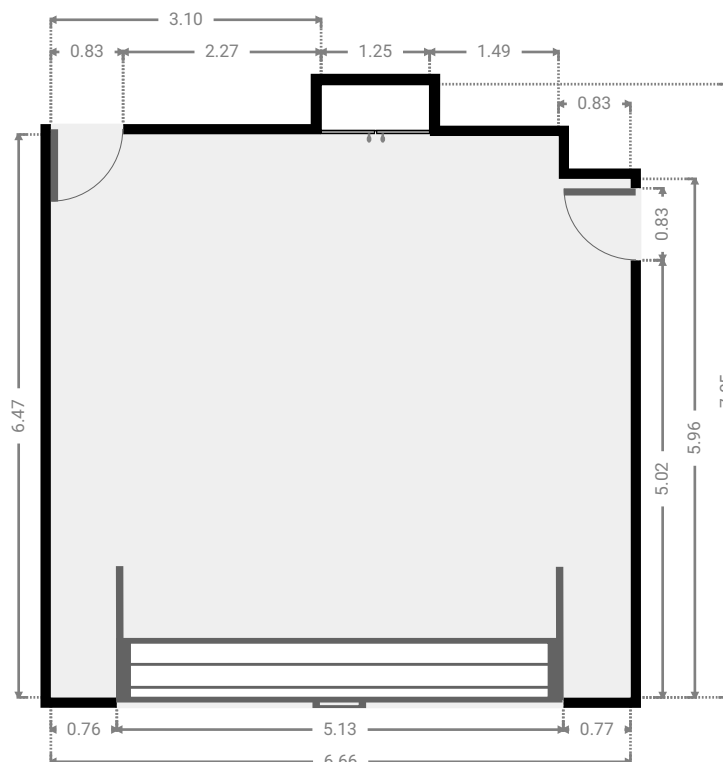
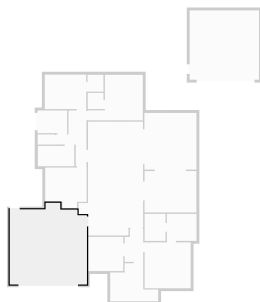

FLOORS: 1

▼ **Hall**
Ground Floor

WIDTH: 2.64 m • LENGTH: 4.81 m
AREA: 7.24 m² • PERIMETER: 14.90 m

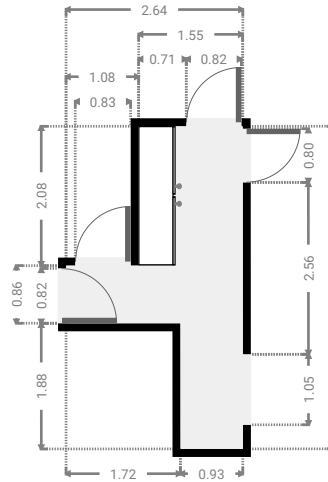
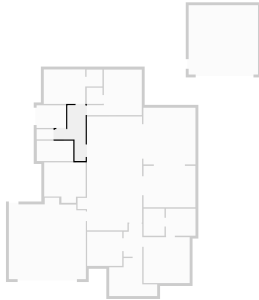

▼ **Kitchen/ Dining / Living**
Ground Floor

WIDTH: 5.59 m • LENGTH: 9.85 m
AREA: 46.87 m² • PERIMETER: 30.86 m

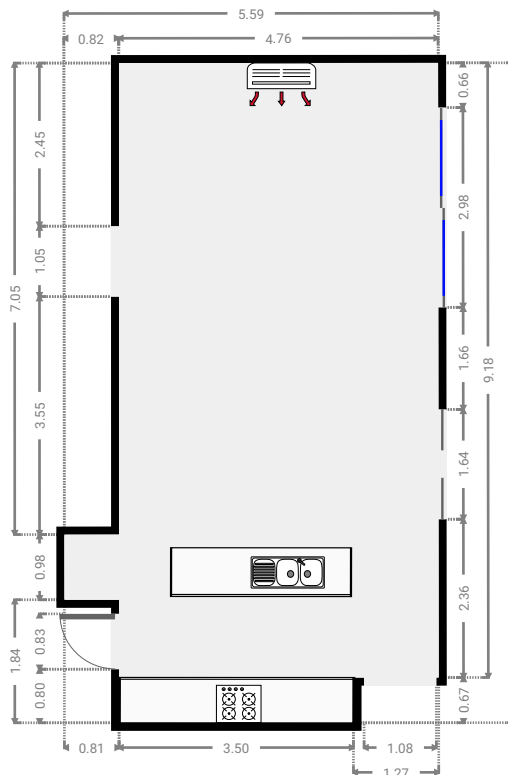
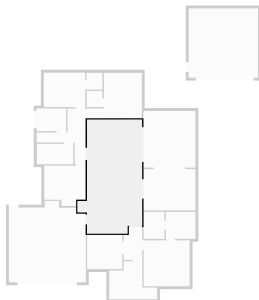

▼ Laundry Room
Ground Floor

WIDTH: 2.55 m • LENGTH: 1.96 m
AREA: 5.00 m² • PERIMETER: 9.02 m

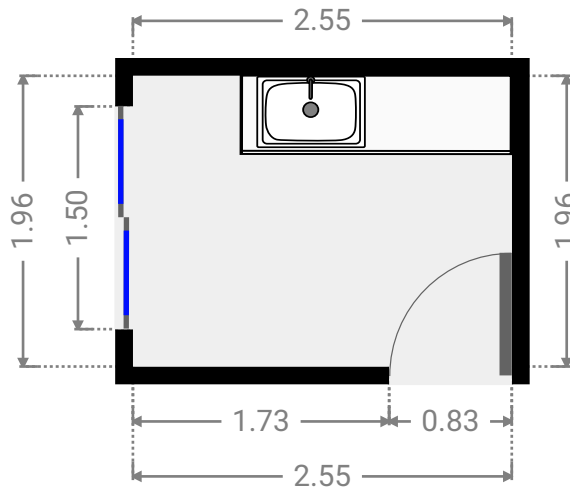
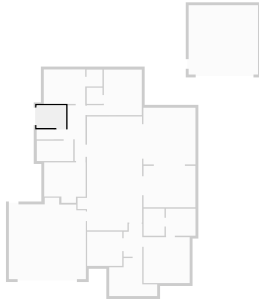

▼ Living Room
Ground Floor

WIDTH: 4.48 m • LENGTH: 3.58 m
AREA: 16.05 m² • PERIMETER: 16.13 m

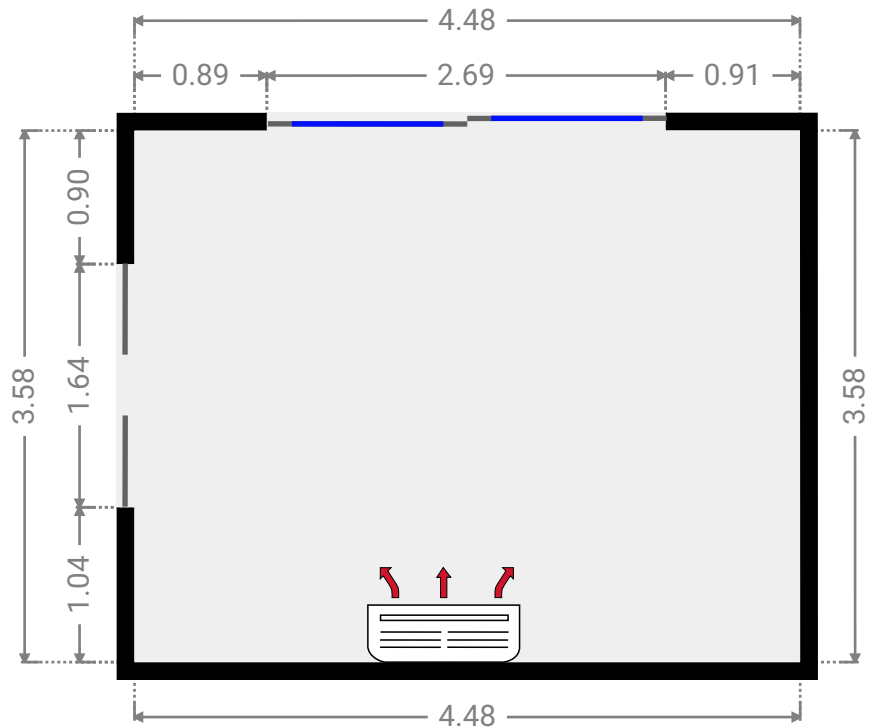
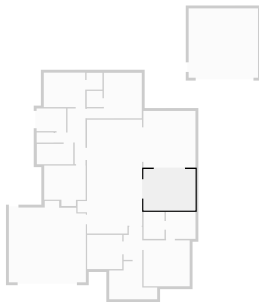

FLOORS: 1

▼ Primary Bedroom
Ground Floor

WIDTH: 3.98 m • LENGTH: 3.97 m
AREA: 15.82 m² • PERIMETER: 15.91 m

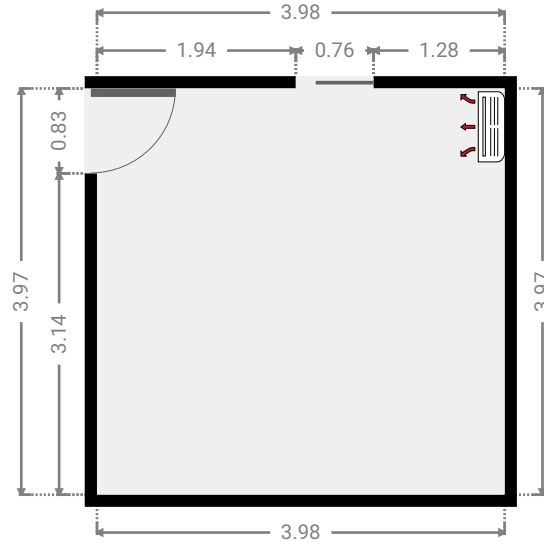

▼ Shed
Ground Floor

WIDTH: 6.00 m • LENGTH: 6.00 m
AREA: 35.97 m² • PERIMETER: 23.99 m

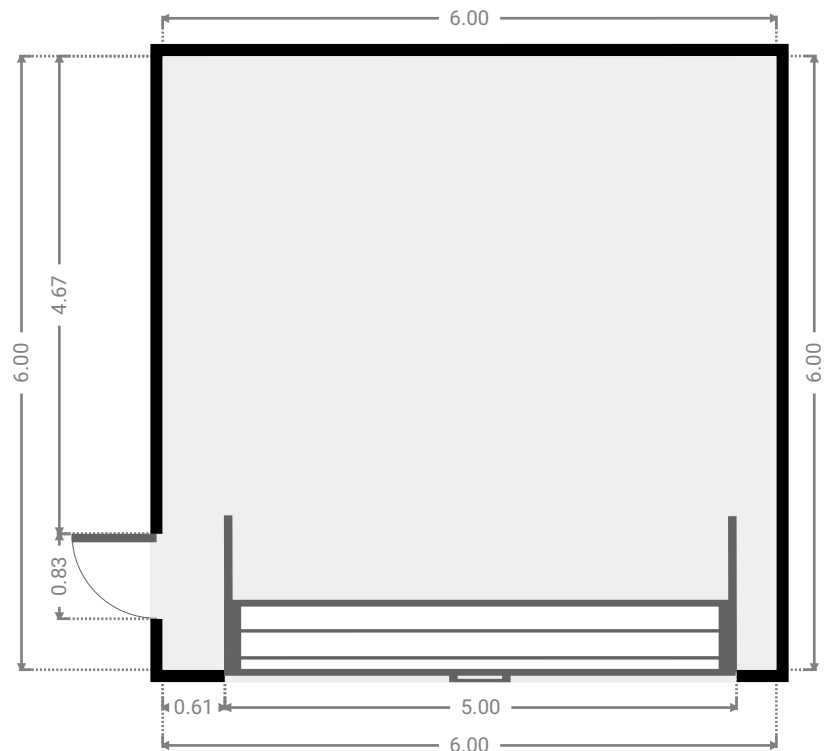
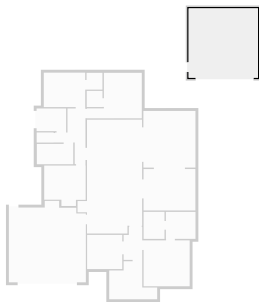

FLOORS: 1

▼ Study
Ground Floor

WIDTH: 3.04 m • LENGTH: 2.96 m
AREA: 8.99 m² • PERIMETER: 12.00 m

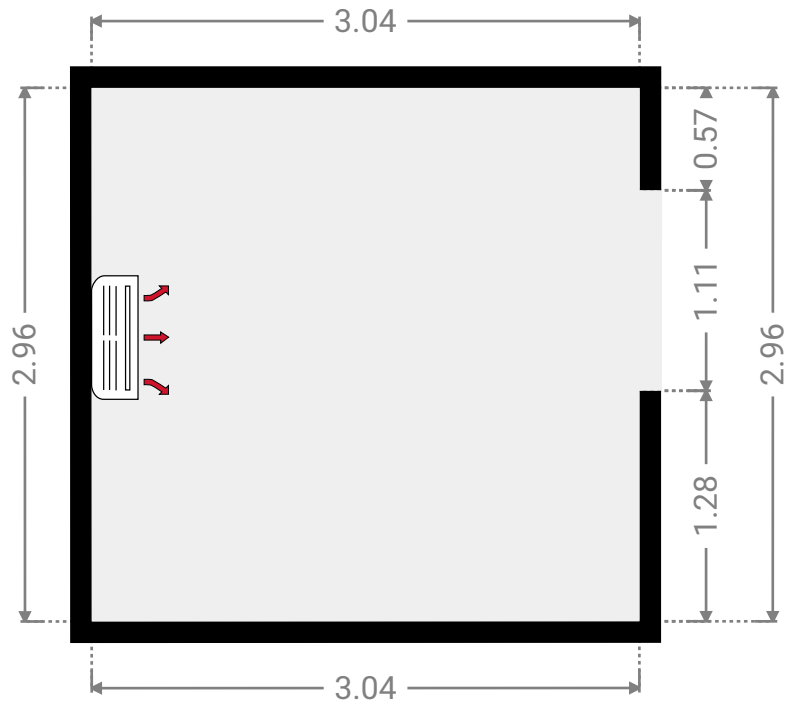
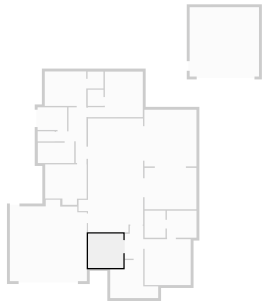

▼ Toilet
Ground Floor

WIDTH: 1.47 m • LENGTH: 0.88 m
AREA: 1.28 m² • PERIMETER: 4.68 m

