

# 20 Stenlake Avenue

**SUBMITTED BY**  
Ray White Rockhampton Casey  
stockers@cqoz.com

---

**CREATED ON**  
2022-04-26

---

**Floors**  
2

---

▼ Ground Floor

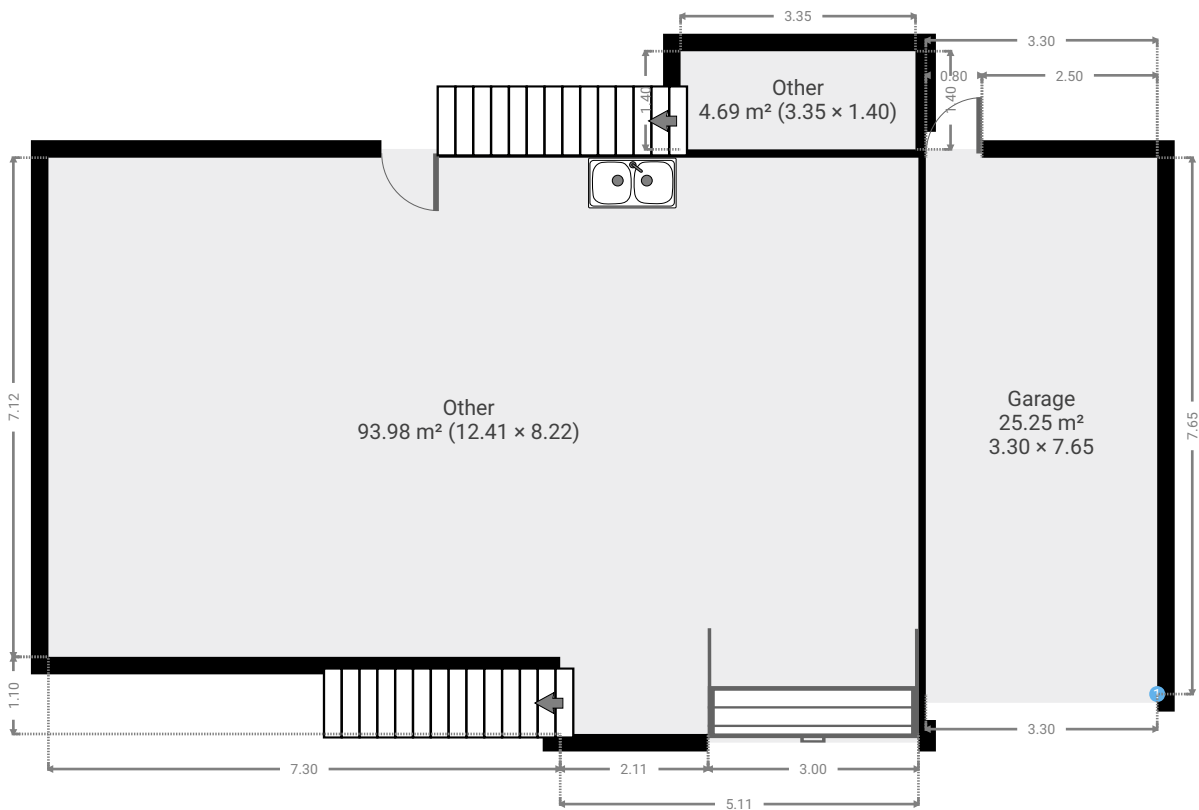
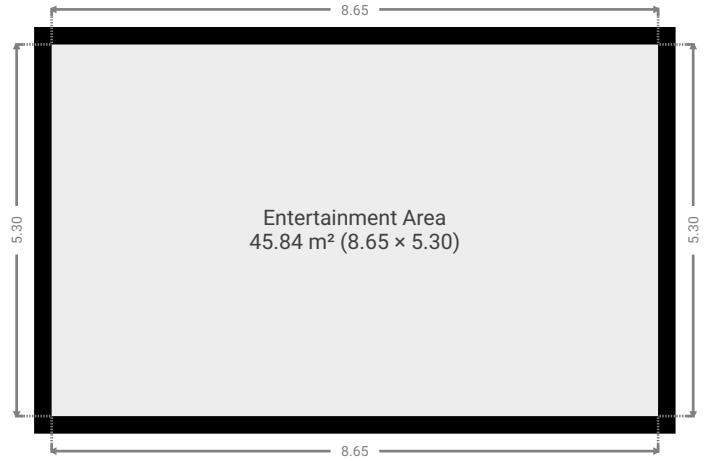

▼ Other  
Ground Floor

WIDTH: 12.41 m • LENGTH: 8.22 m  
AREA: 93.98 m<sup>2</sup> • PERIMETER: 41.26 m

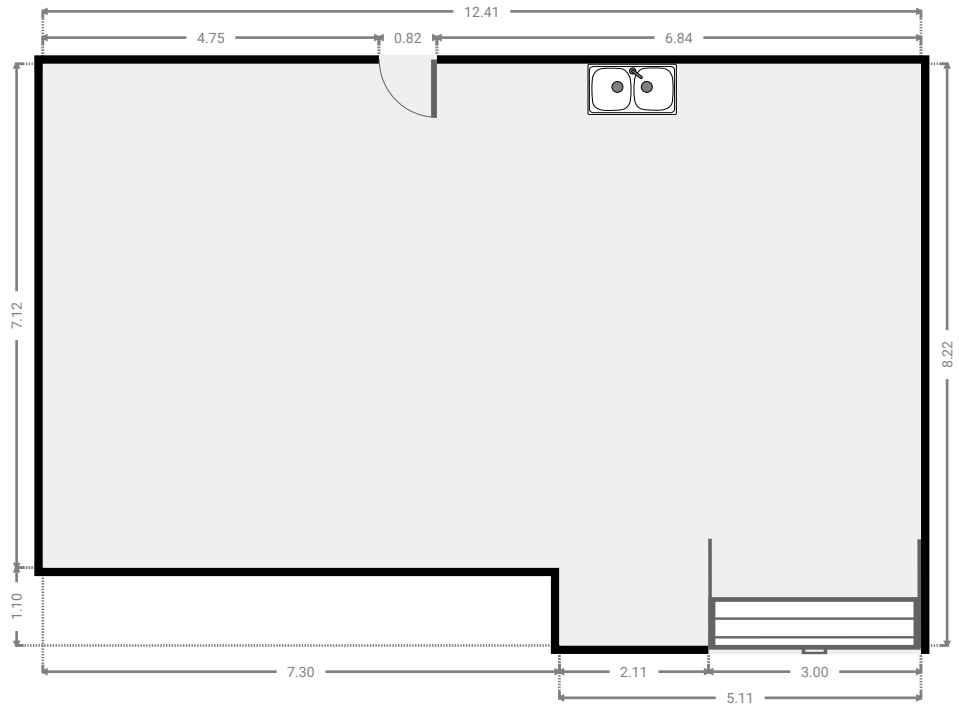
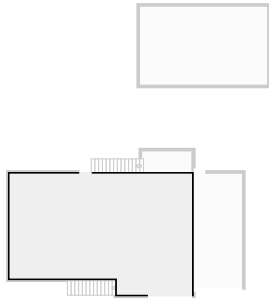

▼ Entertainment Area  
Ground Floor

WIDTH: 8.65 m • LENGTH: 5.30 m  
AREA: 45.84 m<sup>2</sup> • PERIMETER: 27.90 m

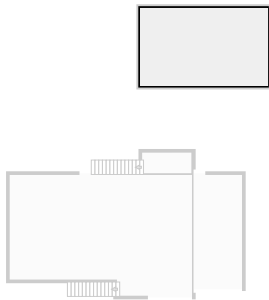

▼ **Garage**  
Ground Floor

WIDTH: 3.30 m • LENGTH: 7.65 m  
AREA: 25.25 m<sup>2</sup> • PERIMETER: 21.90 m

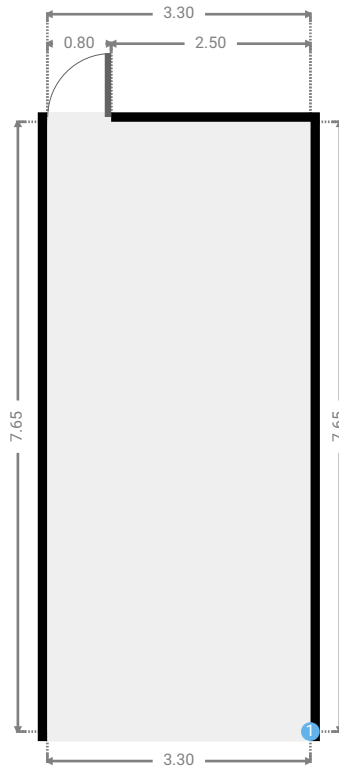
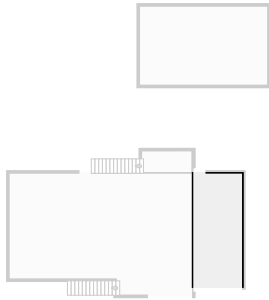

▼ **Garage/Ground Floor**

1 **OPENING**

Height  
0.00 m



▼ Other  
Ground Floor

WIDTH: 3.35 m • LENGTH: 1.40 m  
AREA: 4.69 m<sup>2</sup> • PERIMETER: 9.50 m

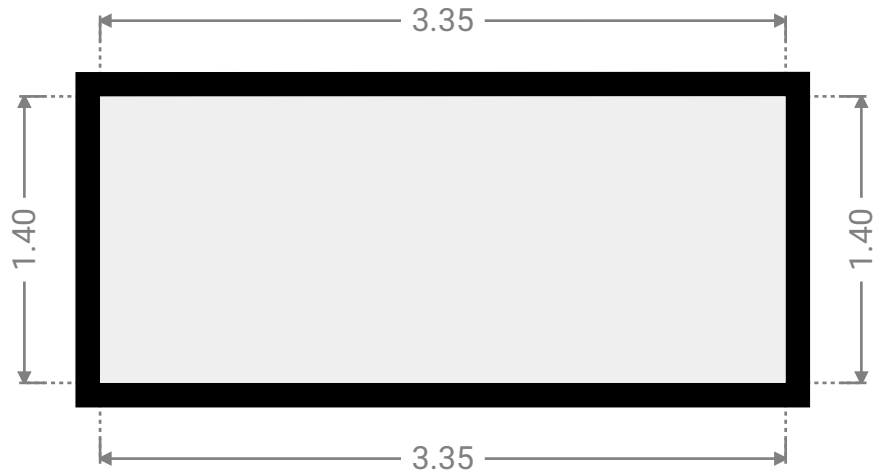
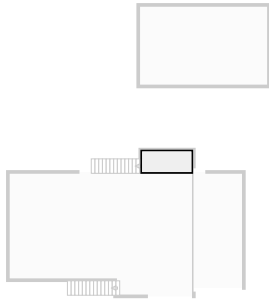

▼ 1st Floor

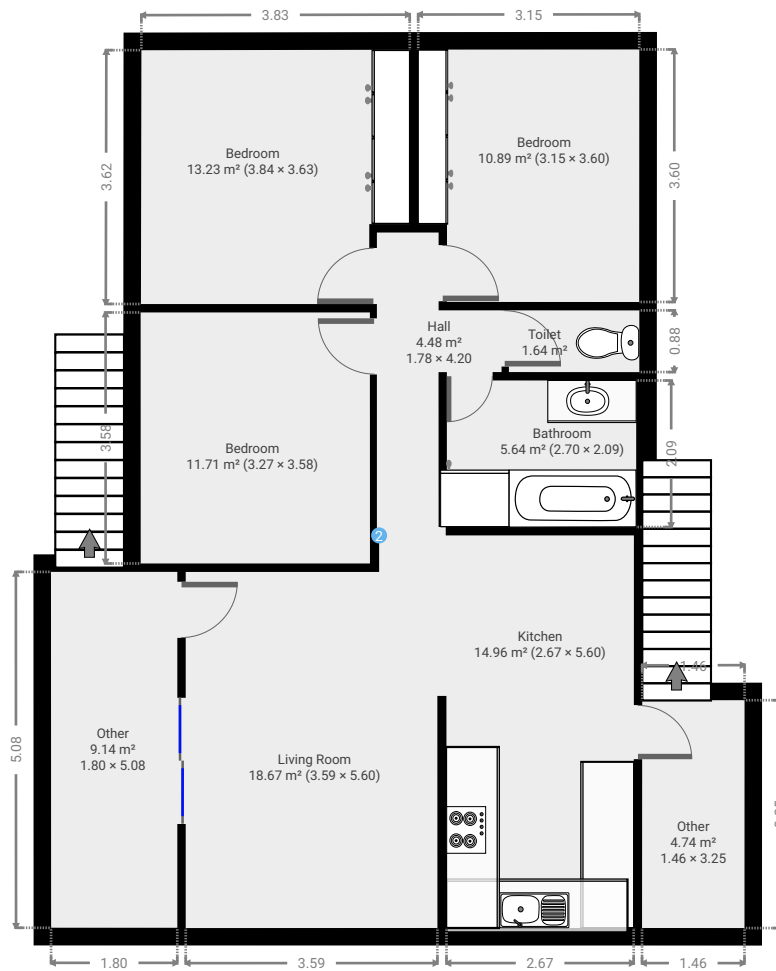

▼ **Living Room**  
1st Floor

WIDTH: 5.60 m • LENGTH: 3.59 m  
AREA: 18.67 m<sup>2</sup> • PERIMETER: 18.38 m

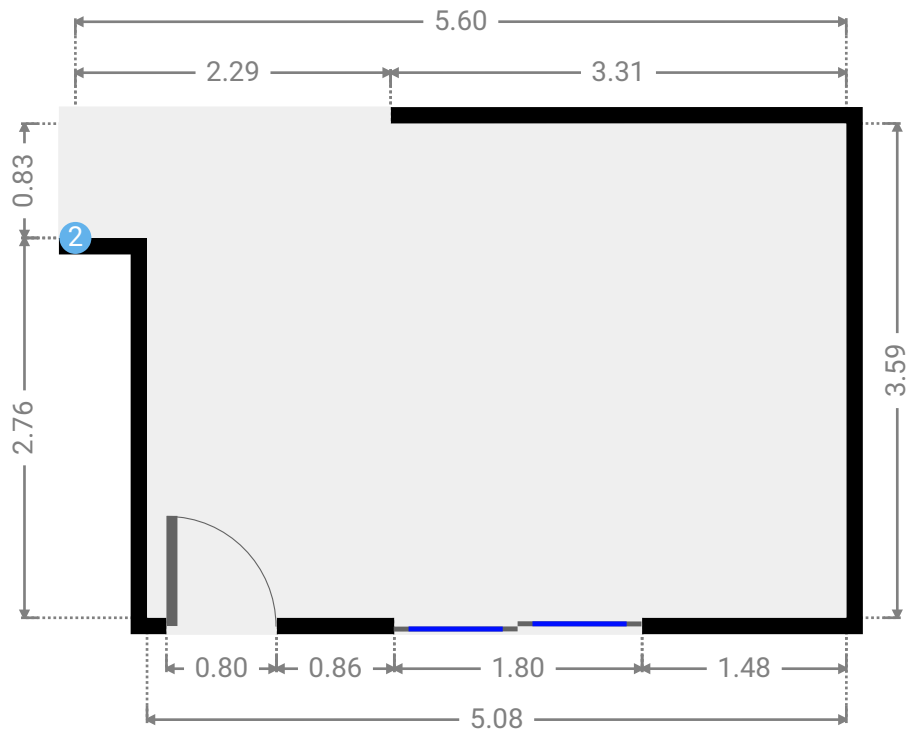
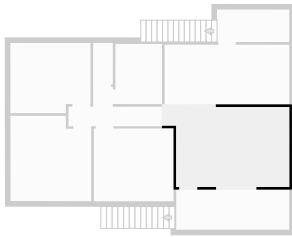

▼ **Living Room/1st Floor**

**2 OPENING**

Height  
0.00 m



▼ **Hall**  
1st Floor

WIDTH: 4.20 m • LENGTH: 1.78 m  
AREA: 4.48 m<sup>2</sup> • PERIMETER: 11.96 m

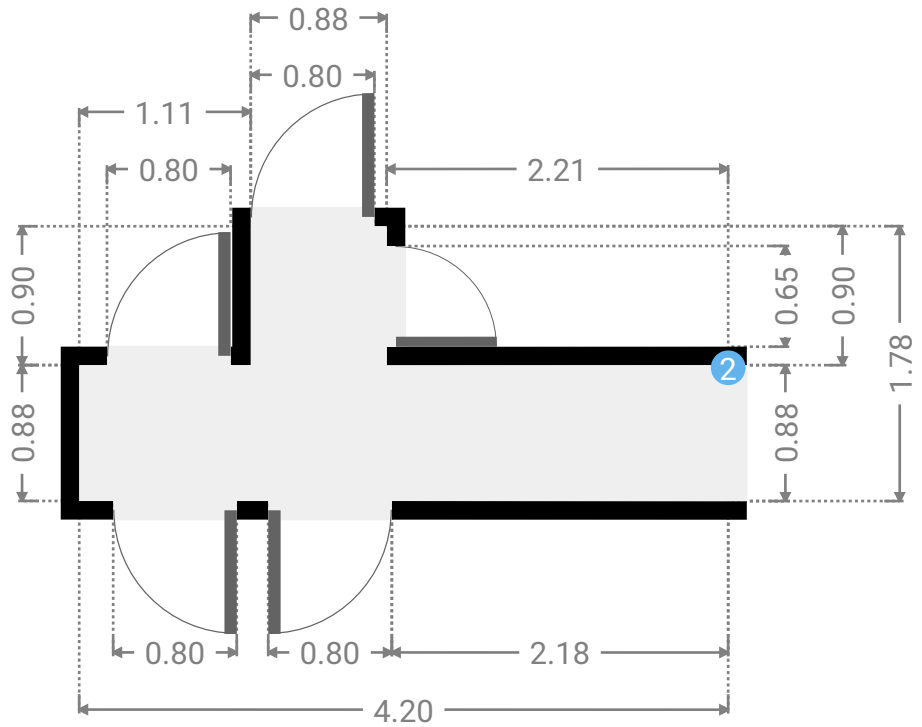
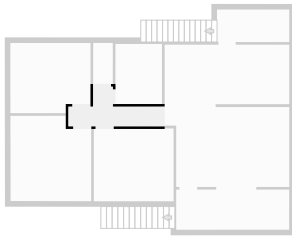

▼ **Bedroom**  
1st Floor

WIDTH: 3.58 m • LENGTH: 3.27 m  
AREA: 11.71 m<sup>2</sup> • PERIMETER: 13.70 m

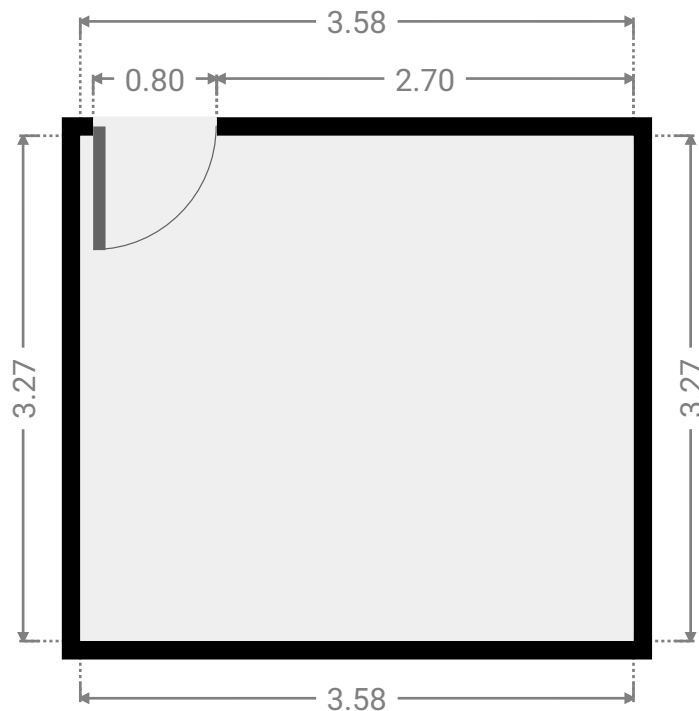
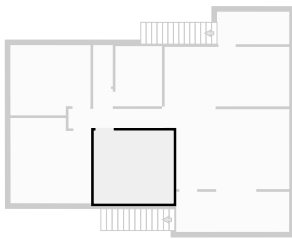



▼ **Bedroom**  
1st Floor

WIDTH: 3.63 m • LENGTH: 3.84 m  
AREA: 13.23 m<sup>2</sup> • PERIMETER: 14.91 m

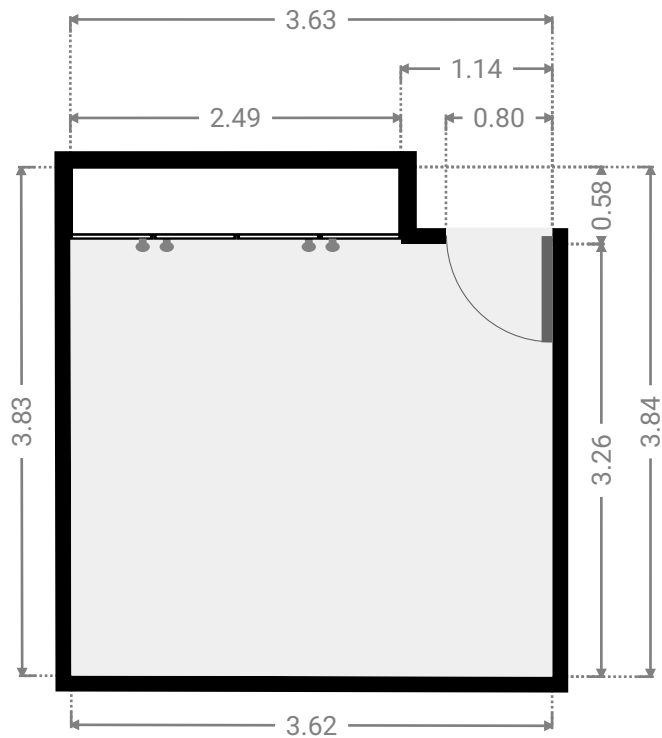
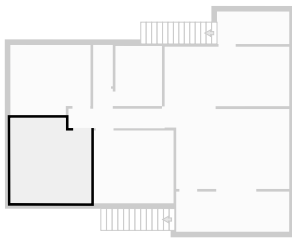

▼ **Kitchen**  
1st Floor

WIDTH: 5.60 m • LENGTH: 2.67 m  
AREA: 14.96 m<sup>2</sup> • PERIMETER: 16.54 m

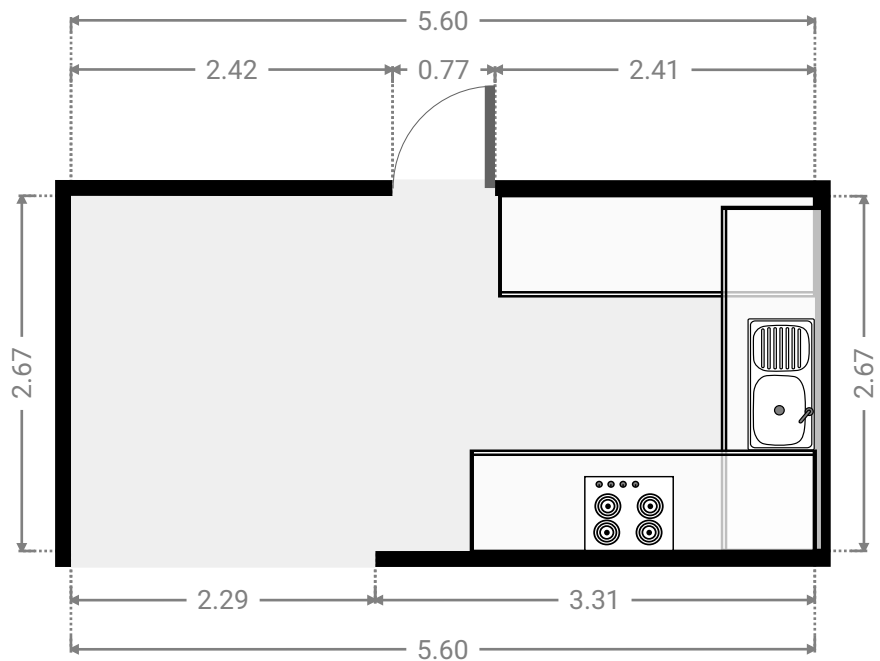
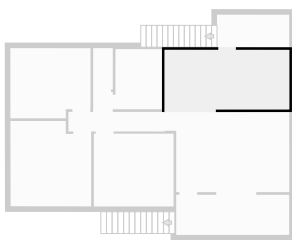

▼ **Bathroom**  
1st Floor

WIDTH: 2.09 m • LENGTH: 2.70 m  
AREA: 5.64 m<sup>2</sup> • PERIMETER: 9.58 m

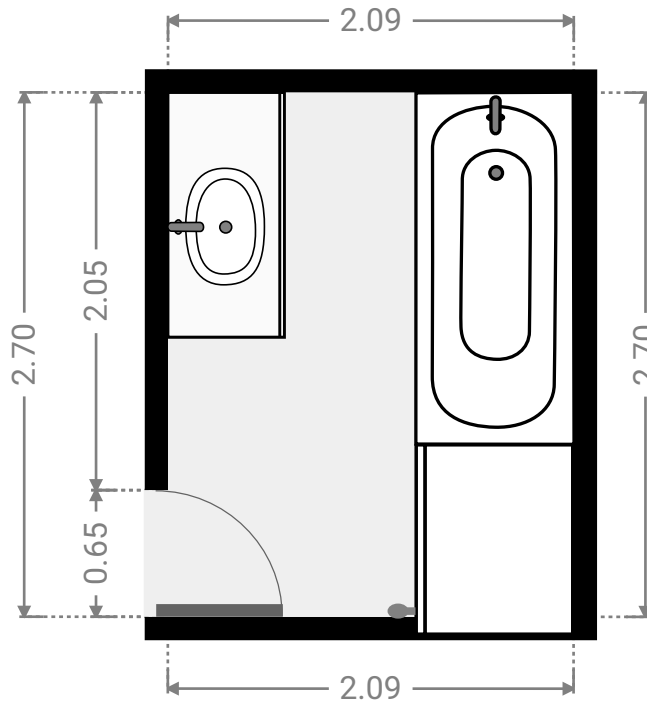
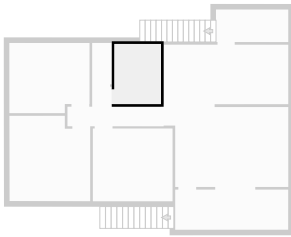

▼ **Toilet**  
1st Floor

WIDTH: 0.88 m • LENGTH: 1.86 m  
AREA: 1.64 m<sup>2</sup> • PERIMETER: 5.48 m

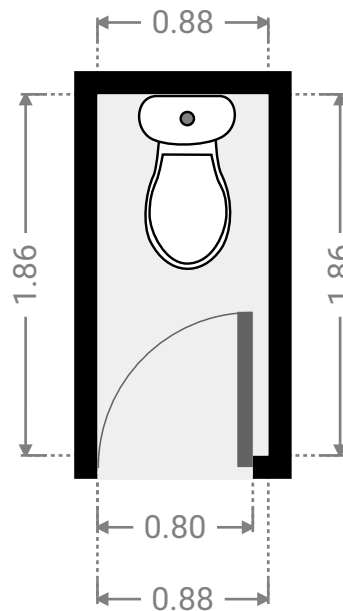
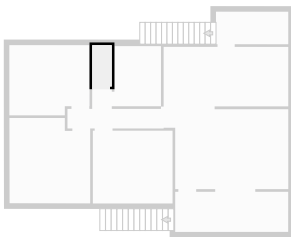

▼ **Bedroom**  
1st Floor

WIDTH: 3.60 m • LENGTH: 3.15 m  
AREA: 10.89 m<sup>2</sup> • PERIMETER: 13.51 m

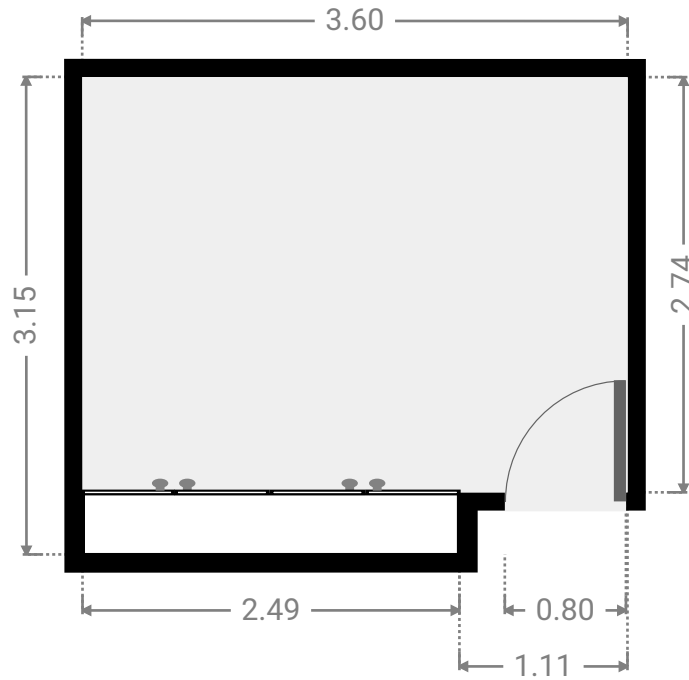
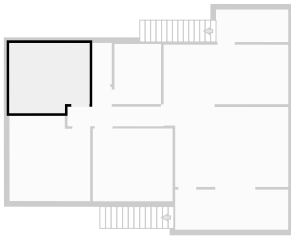

▼ **Other**  
1st Floor

WIDTH: 5.08 m • LENGTH: 1.80 m  
AREA: 9.14 m<sup>2</sup> • PERIMETER: 13.76 m

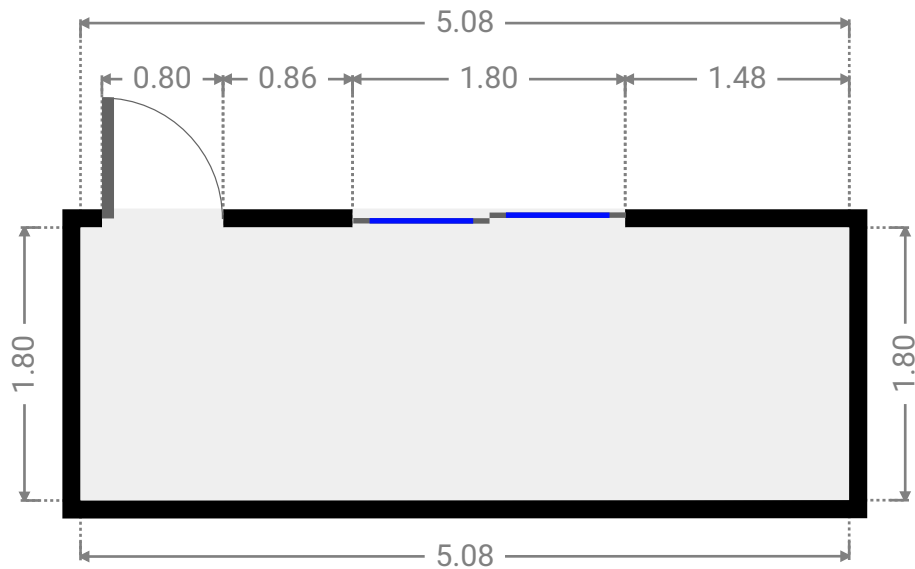
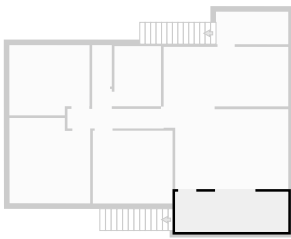

▼ Other  
1st Floor

WIDTH: 3.25 m • LENGTH: 1.46 m  
AREA: 4.74 m<sup>2</sup> • PERIMETER: 9.42 m

