

20 Benjamin Drive

SUBMITTED BY
Ray White Rockhampton Casey
stockers@cqoz.com

CREATED ON
2021-12-22

Floors
1

▼ Ground Floor

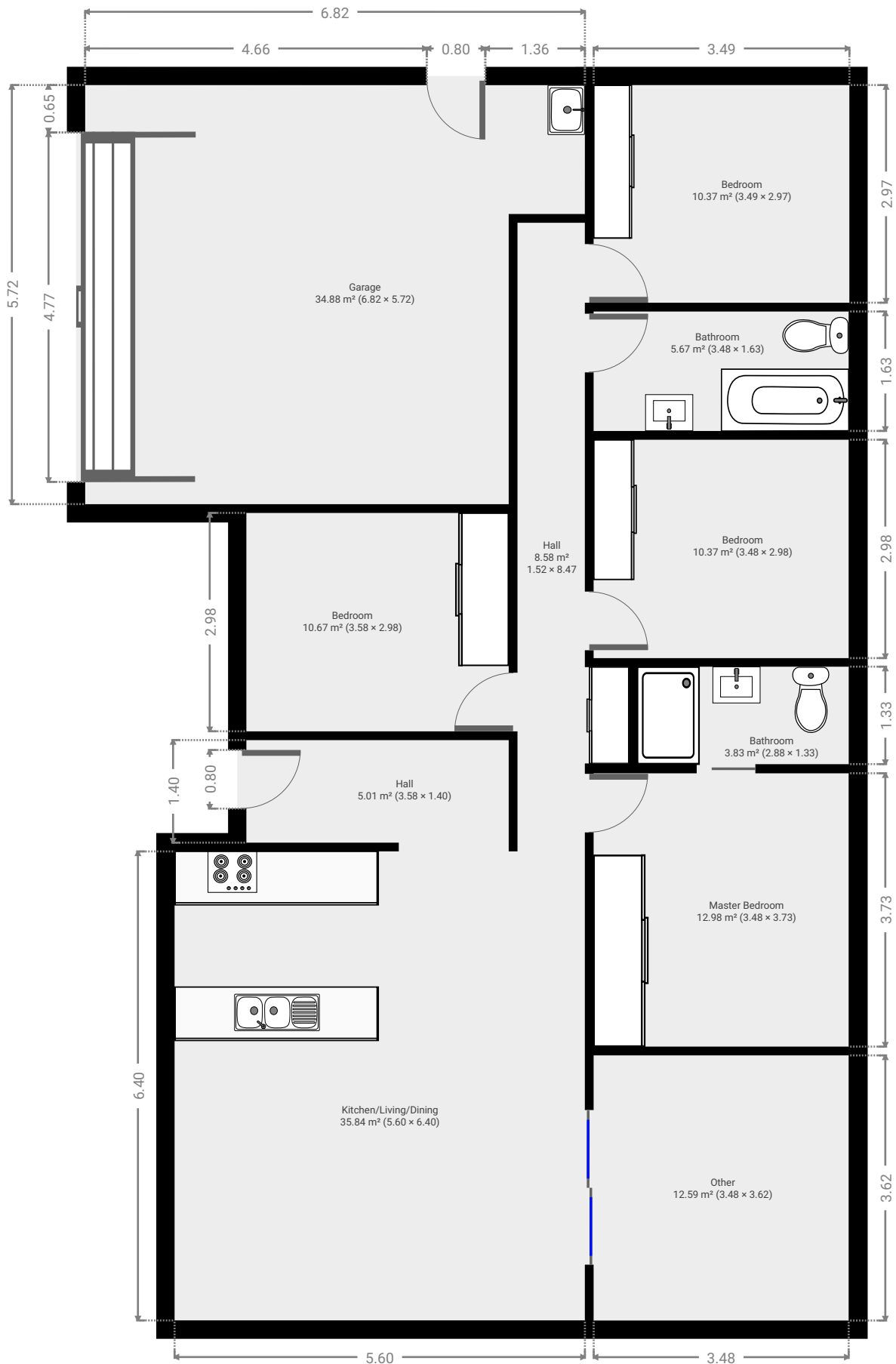

▼ Hall Ground Floor

WIDTH: 1.40 m • LENGTH: 3.58 m
AREA: 5.01 m² • PERIMETER: 9.96 m

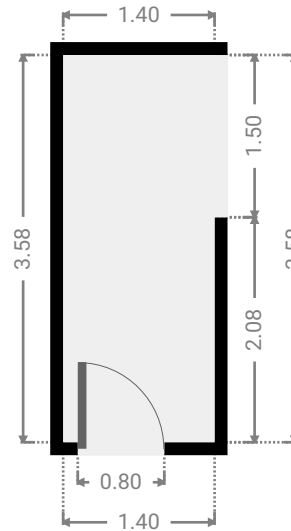
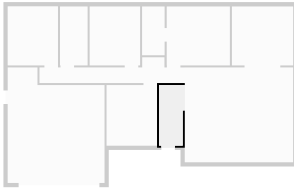

▼ Kitchen/Living/Dining Ground Floor

WIDTH: 6.40 m • LENGTH: 5.60 m
AREA: 35.84 m² • PERIMETER: 24.00 m

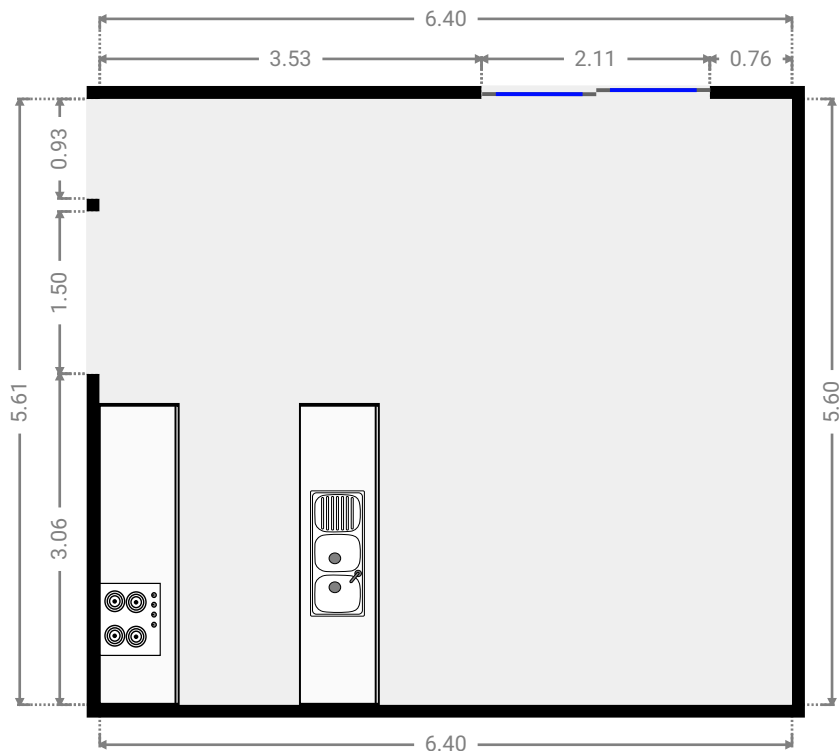
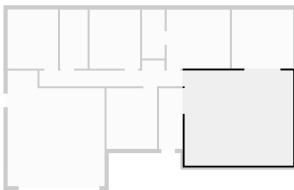

FLOORS: 1

▼ **Hall**
Ground Floor

WIDTH: 8.47 m • LENGTH: 1.52 m
AREA: 8.58 m² • PERIMETER: 19.98 m

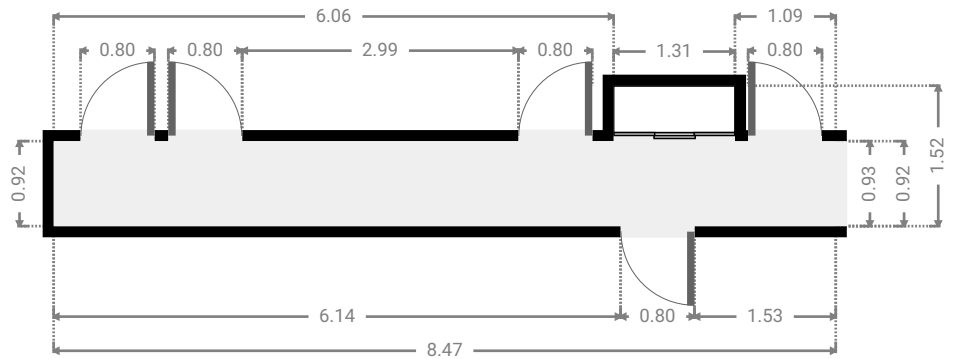
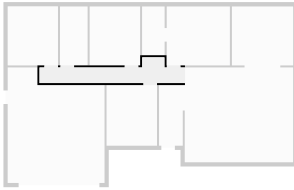

▼ **Master Bedroom**
Ground Floor

WIDTH: 3.73 m • LENGTH: 3.48 m
AREA: 12.98 m² • PERIMETER: 14.42 m

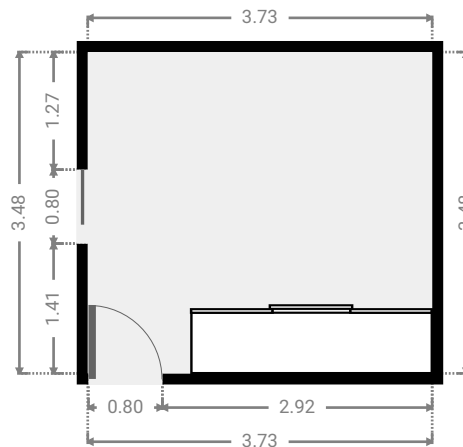
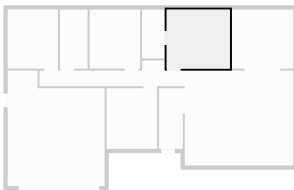

▼ **Bathroom**
Ground Floor

WIDTH: 1.33 m • LENGTH: 2.88 m
AREA: 3.83 m² • PERIMETER: 8.42 m

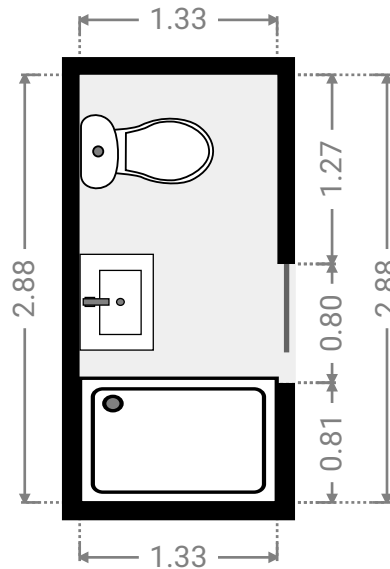
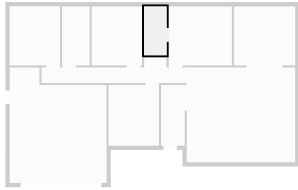

▼ **Bedroom**
Ground Floor

WIDTH: 2.98 m • LENGTH: 3.58 m
AREA: 10.67 m² • PERIMETER: 13.12 m

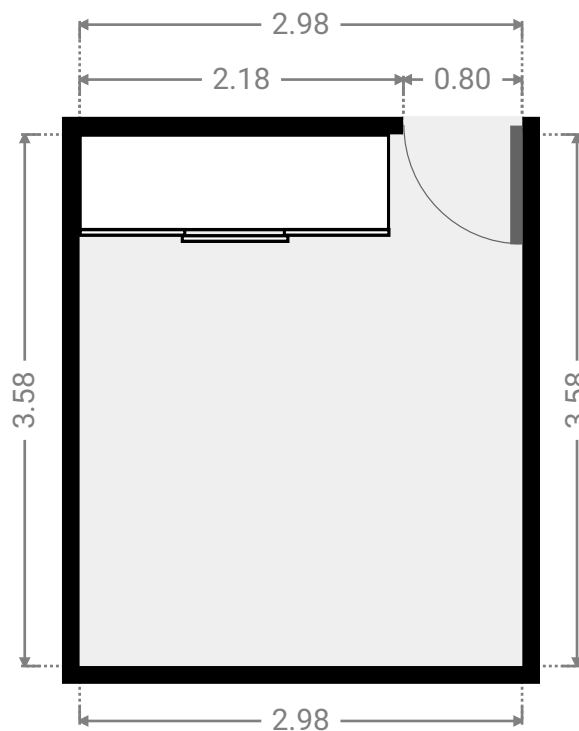
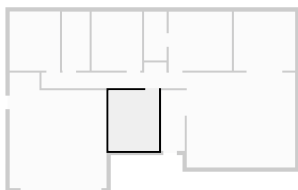

▼ **Bedroom**
Ground Floor

WIDTH: 2.98 m • LENGTH: 3.48 m
AREA: 10.37 m² • PERIMETER: 12.92 m

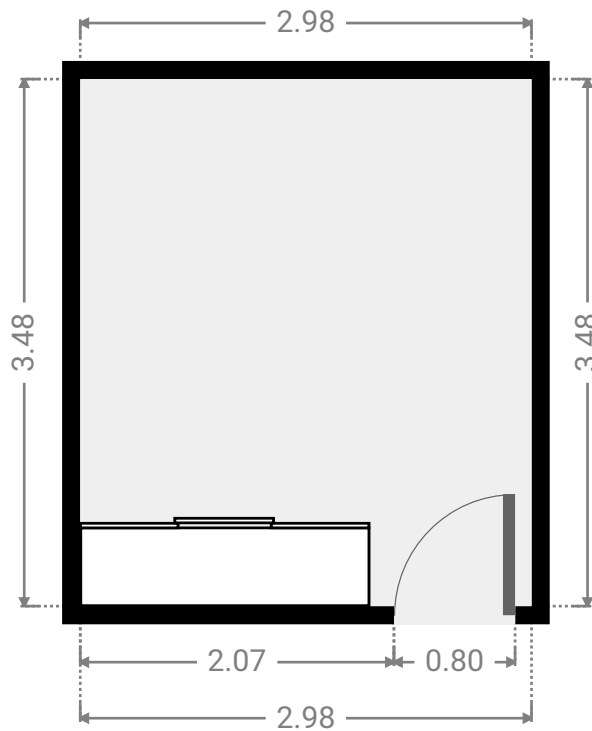
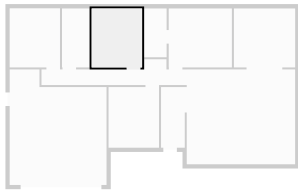

▼ **Bathroom**
Ground Floor

WIDTH: 1.63 m • LENGTH: 3.48 m
AREA: 5.67 m² • PERIMETER: 10.22 m

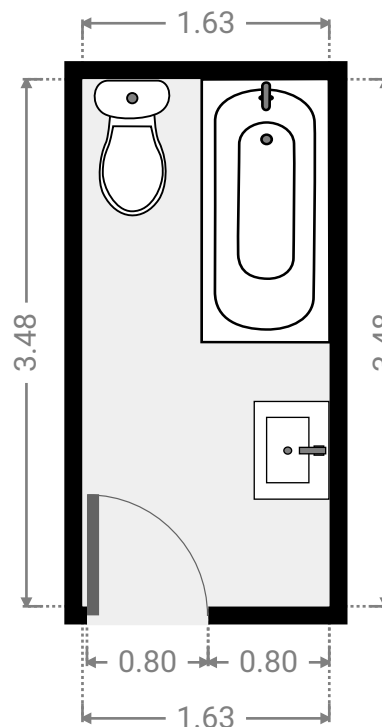
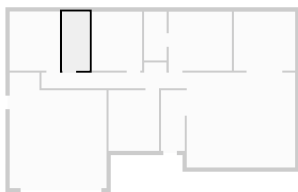

▼ Bedroom Ground Floor

WIDTH: 2.97 m • LENGTH: 3.49 m
AREA: 10.37 m² • PERIMETER: 12.92 m

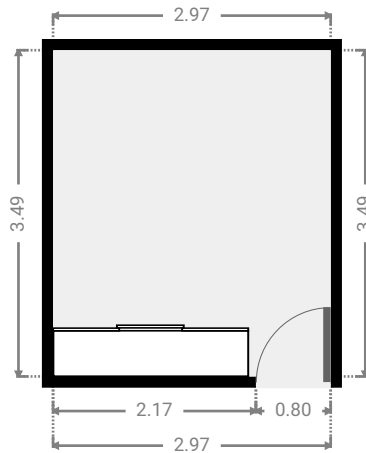
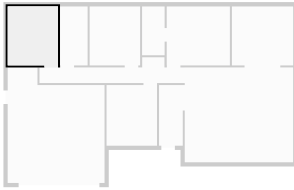

▼ Garage Ground Floor

WIDTH: 5.72 m • LENGTH: 6.82 m
AREA: 34.88 m² • PERIMETER: 25.08 m

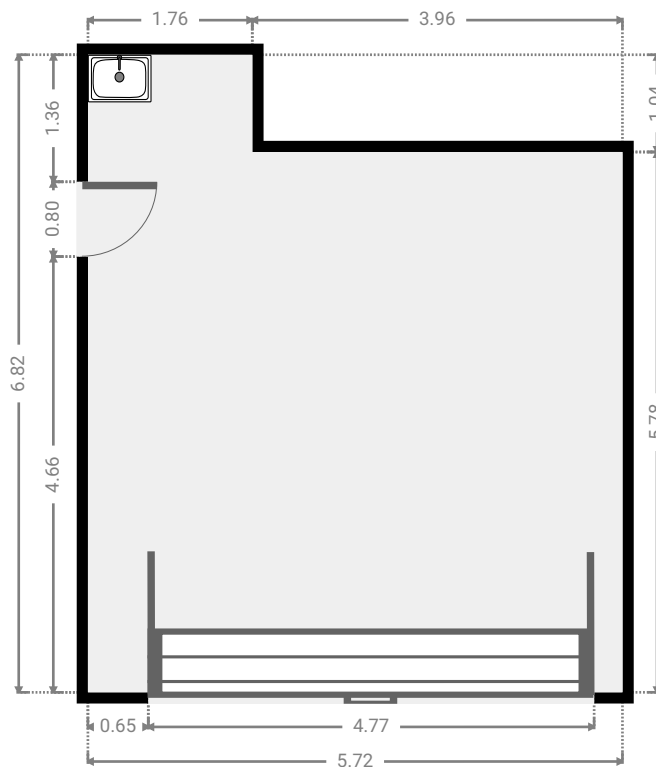
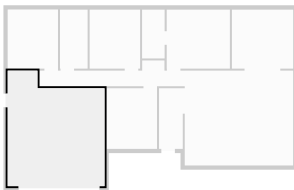

▼ Other
Ground Floor

WIDTH: 3.62 m • LENGTH: 3.48 m
AREA: 12.59 m² • PERIMETER: 14.20 m

