

2-4 Darr Avenue

Created on
2021-03-11

Floors
1

▼ Ground Floor

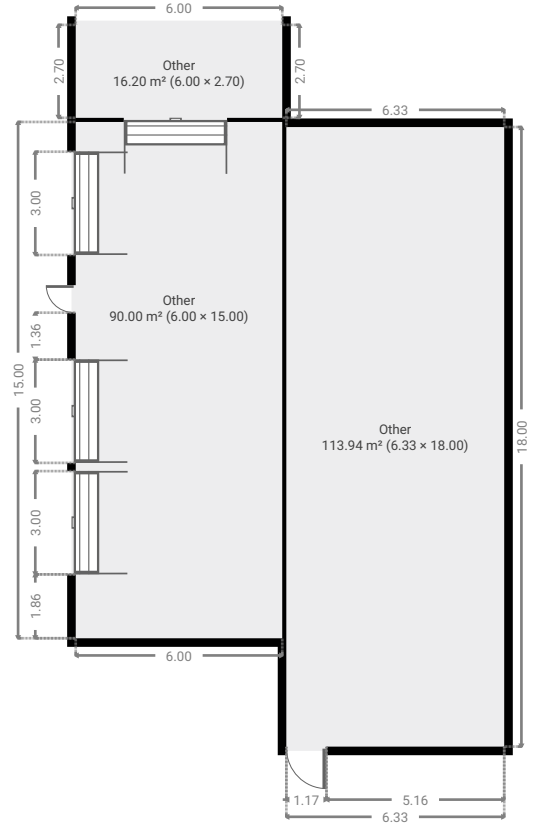
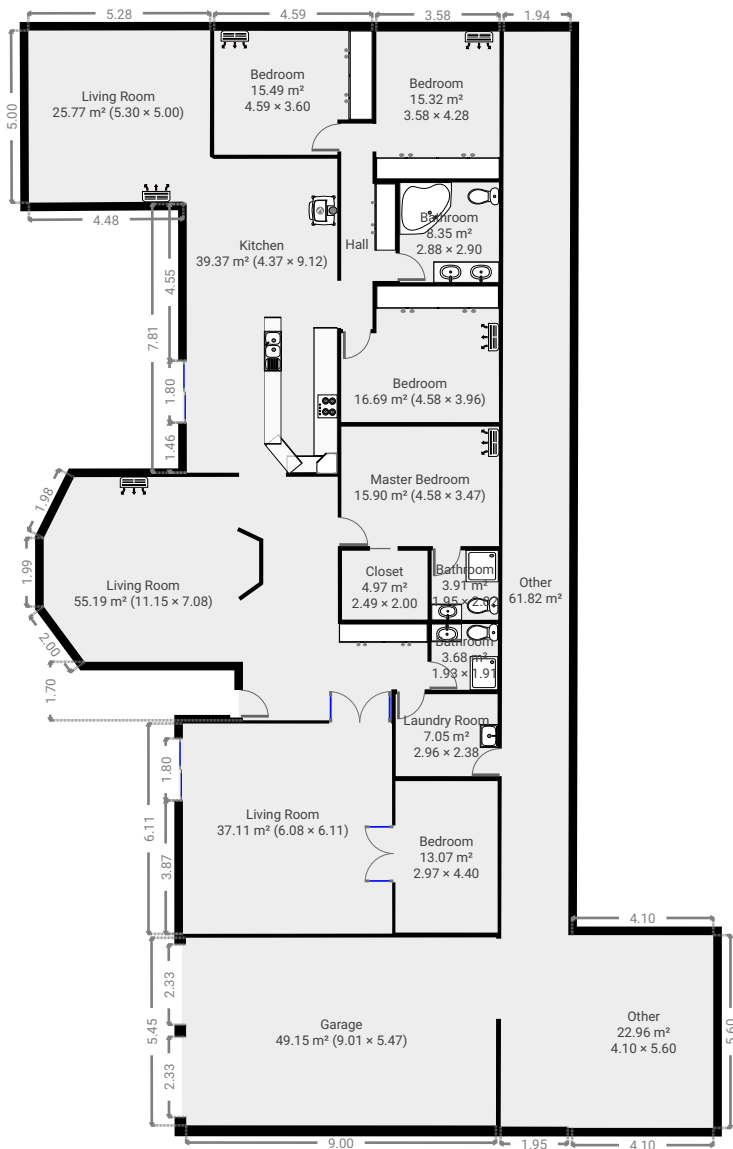

▼ **Hall**
Ground Floor

WIDTH: 5.97 m • LENGTH: 1.58 m
AREA: 7.32 m² • PERIMETER: 15.10 m

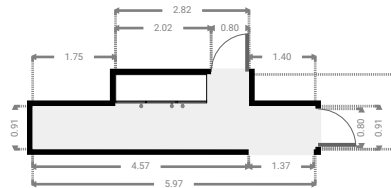
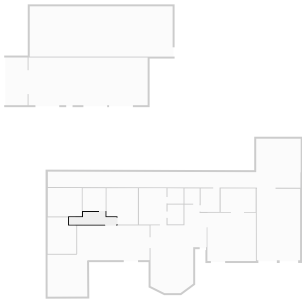

▼ **Other**
Ground Floor

WIDTH: 18.00 m • LENGTH: 6.33 m
AREA: 113.94 m² • PERIMETER: 48.66 m

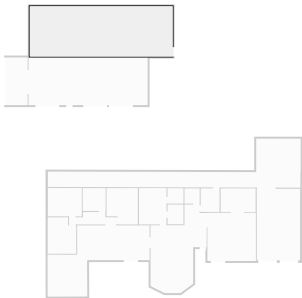

▼ Other
Ground Floor

WIDTH: 15.00 m • LENGTH: 6.00 m
AREA: 90.00 m² • PERIMETER: 42.00 m

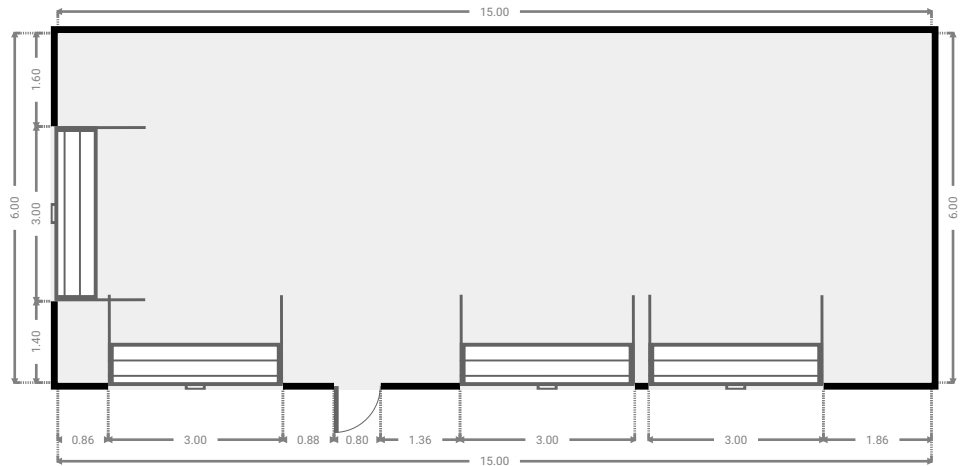
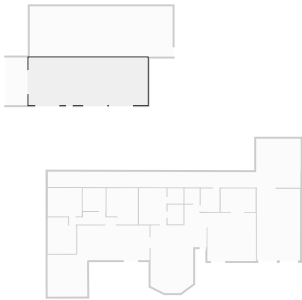

▼ Other
Ground Floor

WIDTH: 2.70 m • LENGTH: 6.00 m
AREA: 16.20 m² • PERIMETER: 17.40 m

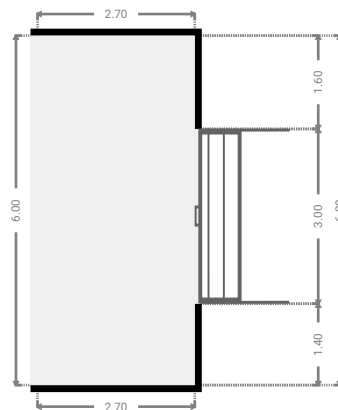

▼ Other
Ground Floor

WIDTH: 5.60 m • LENGTH: 4.10 m
AREA: 22.96 m² • PERIMETER: 19.40 m

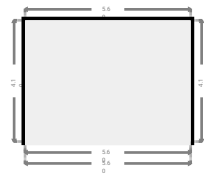
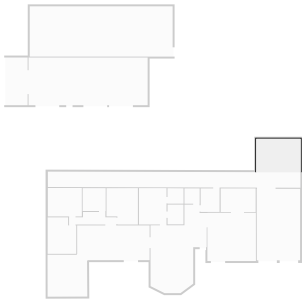

▼ Other
Ground Floor

WIDTH: 31.82 m • LENGTH: 1.95 m
AREA: 61.82 m² • PERIMETER: 67.51 m

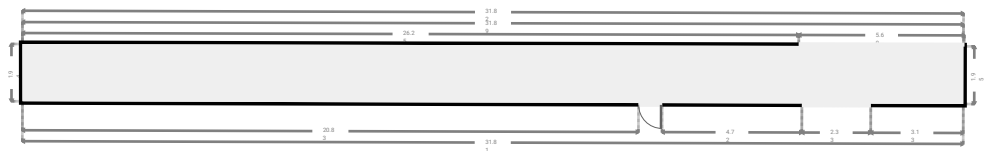
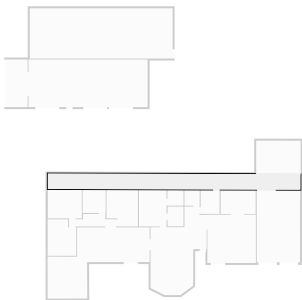

▼ **Garage**
Ground Floor

WIDTH: 5.47 m • LENGTH: 9.01 m
AREA: 49.15 m² • PERIMETER: 28.93 m

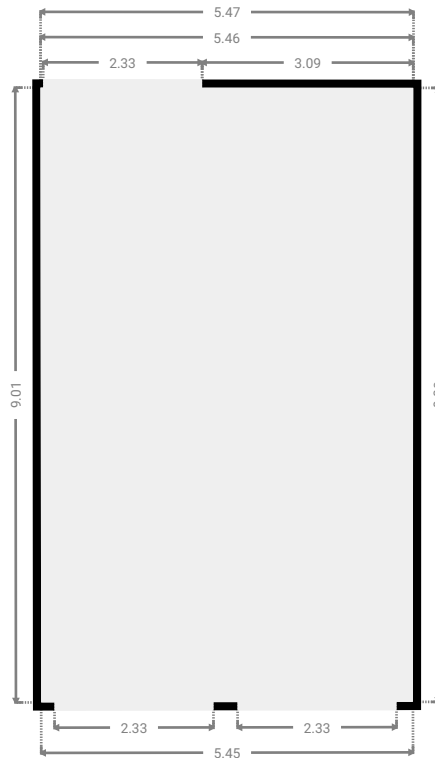
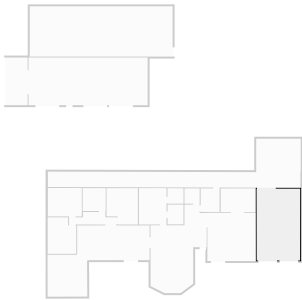

▼ **Bedroom**
Ground Floor

WIDTH: 3.60 m • LENGTH: 4.59 m
AREA: 15.49 m² • PERIMETER: 16.38 m

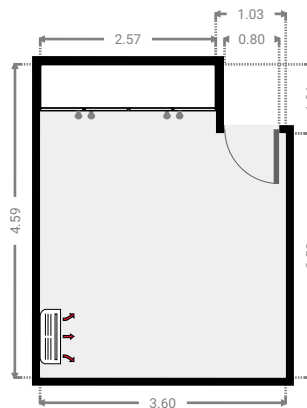

▼ **Bedroom**
Ground Floor

WIDTH: 4.28 m • LENGTH: 3.58 m
AREA: 15.32 m² • PERIMETER: 15.72 m

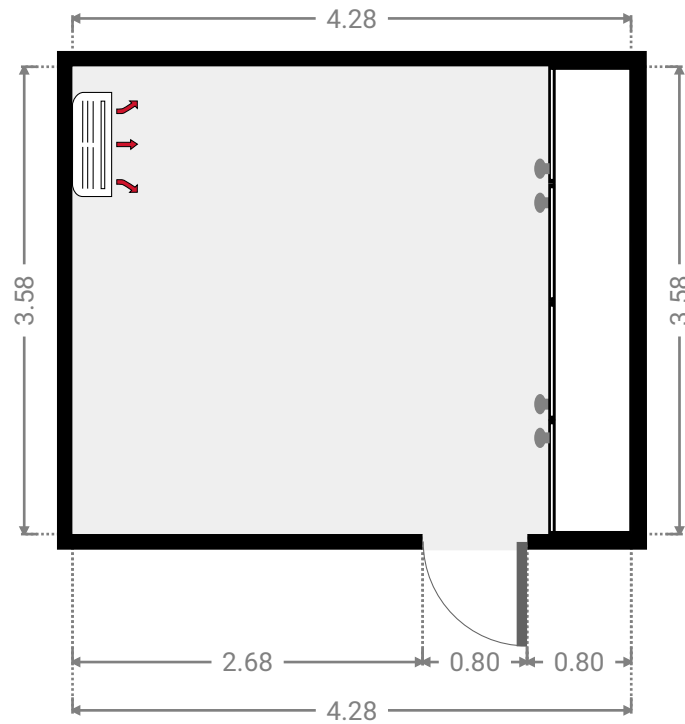
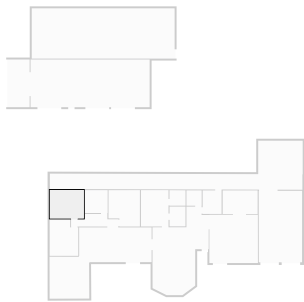

▼ **Bathroom**
Ground Floor

WIDTH: 2.90 m • LENGTH: 2.88 m
AREA: 8.35 m² • PERIMETER: 11.56 m

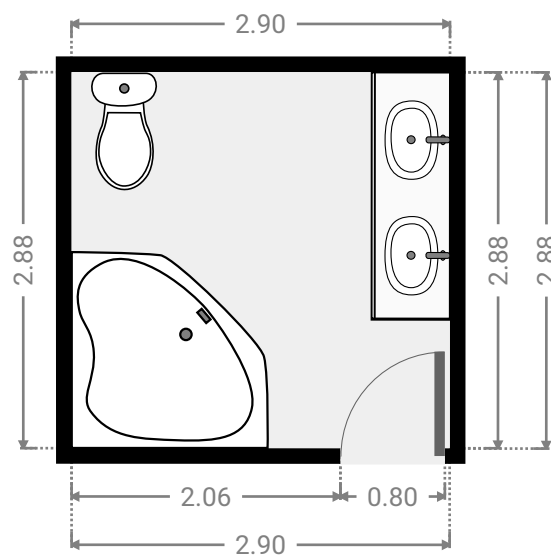

▼ **Bedroom**
Ground Floor

WIDTH: 3.96 m • LENGTH: 4.58 m
AREA: 16.69 m² • PERIMETER: 17.06 m

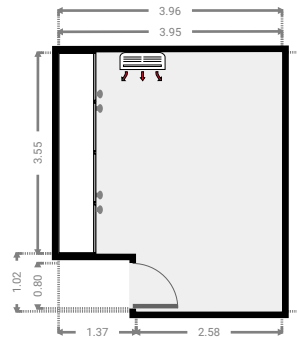

▼ **Living Room**
Ground Floor

WIDTH: 7.08 m • LENGTH: 11.15 m
AREA: 55.19 m² • PERIMETER: 34.97 m

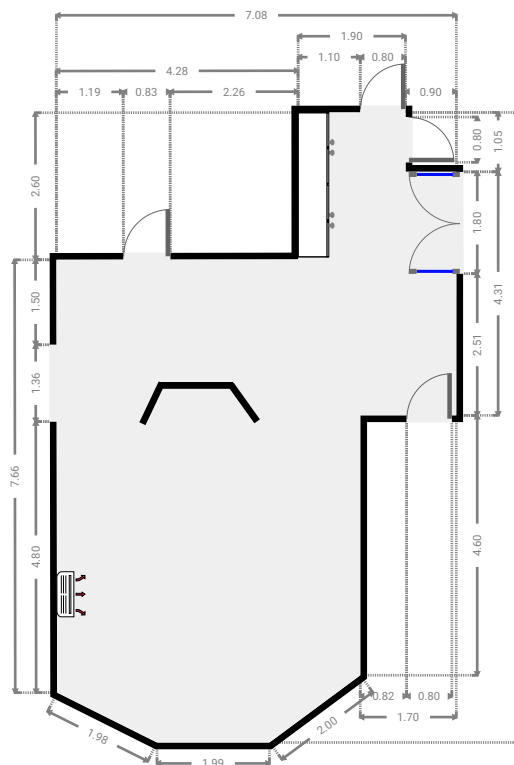
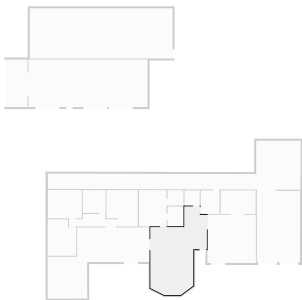

▼ Living Room
Ground Floor

WIDTH: 5.00 m • LENGTH: 5.30 m
AREA: 25.77 m² • PERIMETER: 19.96 m

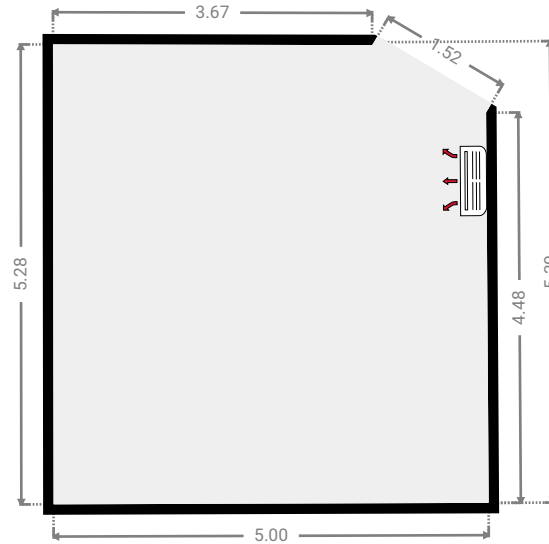
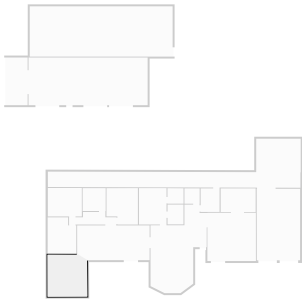

▼ Kitchen
Ground Floor

WIDTH: 9.12 m • LENGTH: 4.37 m
AREA: 39.37 m² • PERIMETER: 26.42 m

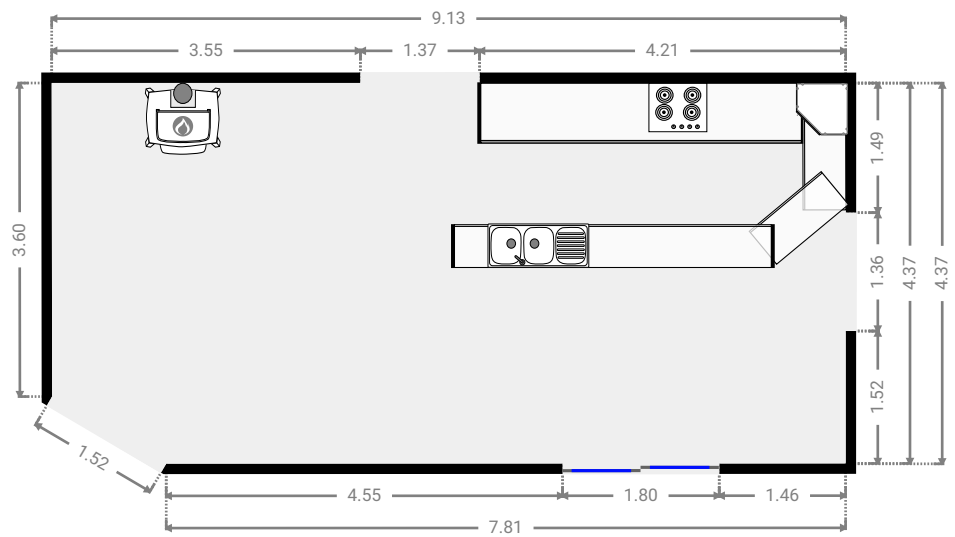
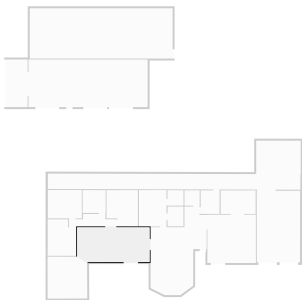

▼ Bathroom
Ground Floor

WIDTH: 2.02 m • LENGTH: 1.95 m
AREA: 3.91 m² • PERIMETER: 7.91 m

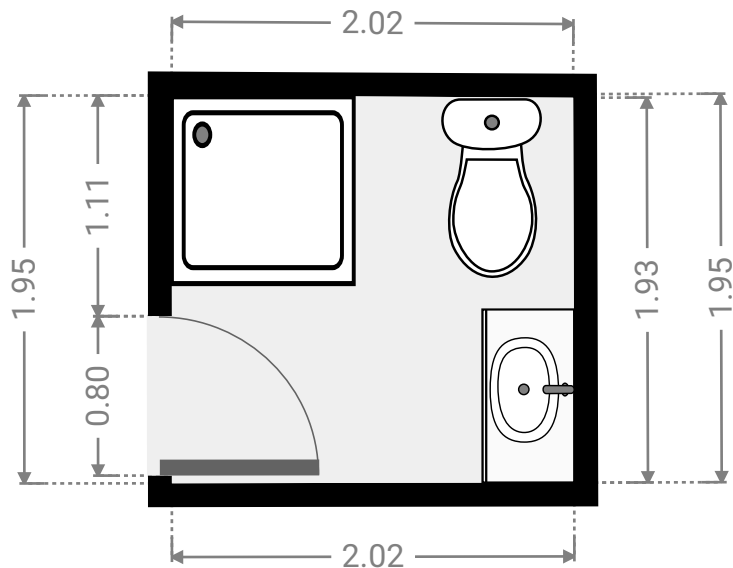

▼ Closet
Ground Floor

WIDTH: 2.00 m • LENGTH: 2.49 m
AREA: 4.97 m² • PERIMETER: 8.97 m

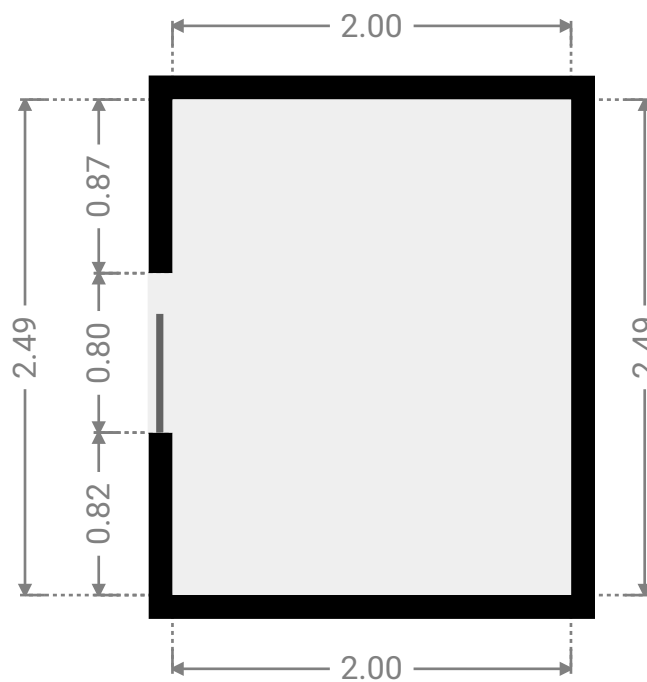

▼ **Master Bedroom**
Ground Floor

WIDTH: 3.47 m • LENGTH: 4.58 m
AREA: 15.90 m² • PERIMETER: 16.10 m

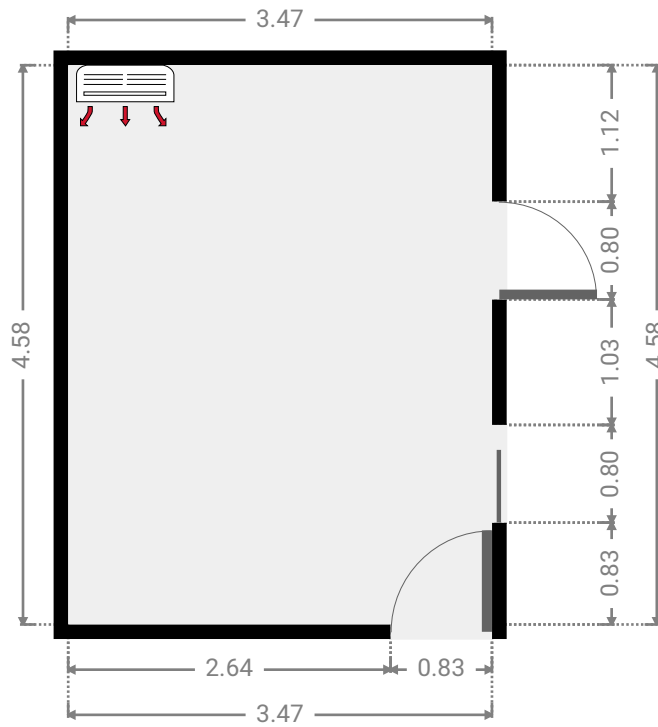

▼ **Bathroom**
Ground Floor

WIDTH: 1.91 m • LENGTH: 1.93 m
AREA: 3.68 m² • PERIMETER: 7.68 m

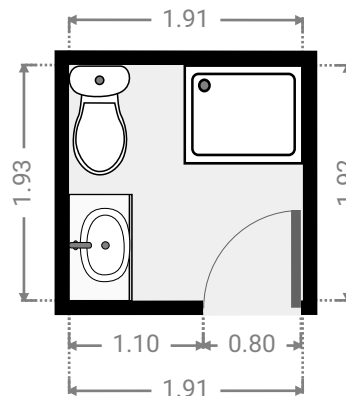

▼ Laundry Room
Ground Floor

WIDTH: 2.38 m • LENGTH: 2.96 m
AREA: 7.05 m² • PERIMETER: 10.68 m

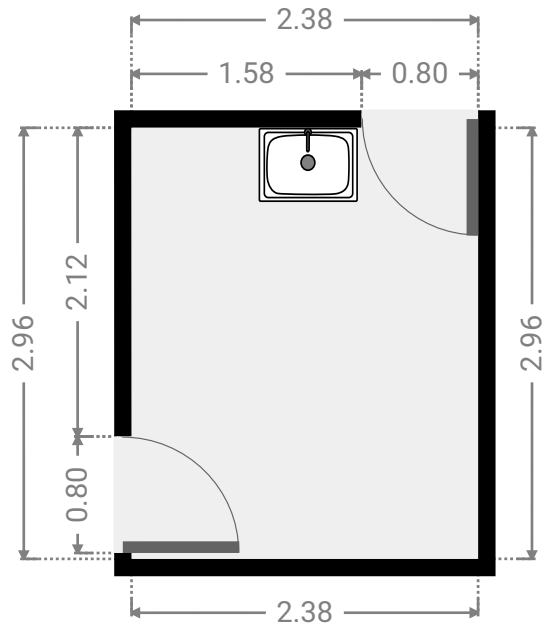
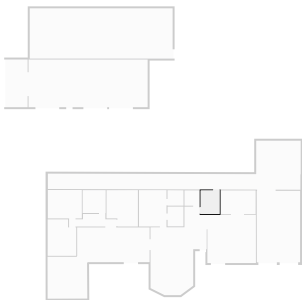

▼ Bedroom
Ground Floor

WIDTH: 4.40 m • LENGTH: 2.97 m
AREA: 13.07 m² • PERIMETER: 14.74 m

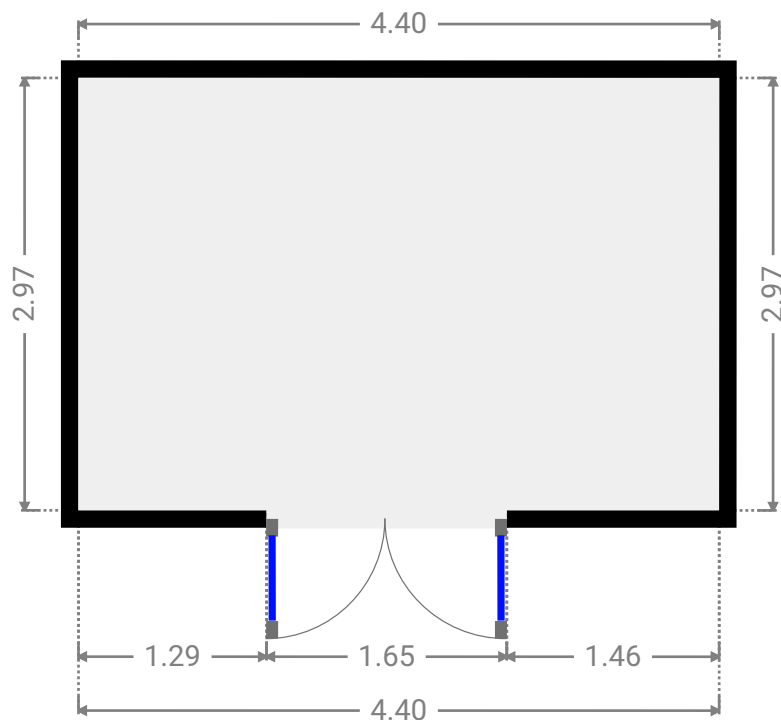
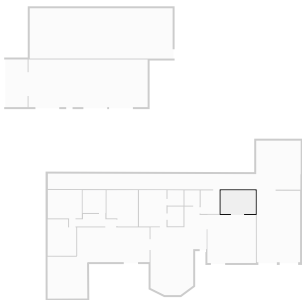

▼ Living Room
Ground Floor

WIDTH: 6.11 m • LENGTH: 6.08 m
AREA: 37.11 m² • PERIMETER: 24.37 m

