

2 Parkdale Terrace

SUBMITTED BY
Janelle Casey

CREATED ON
2021-10-19

Floors 1

▼ Ground Floor

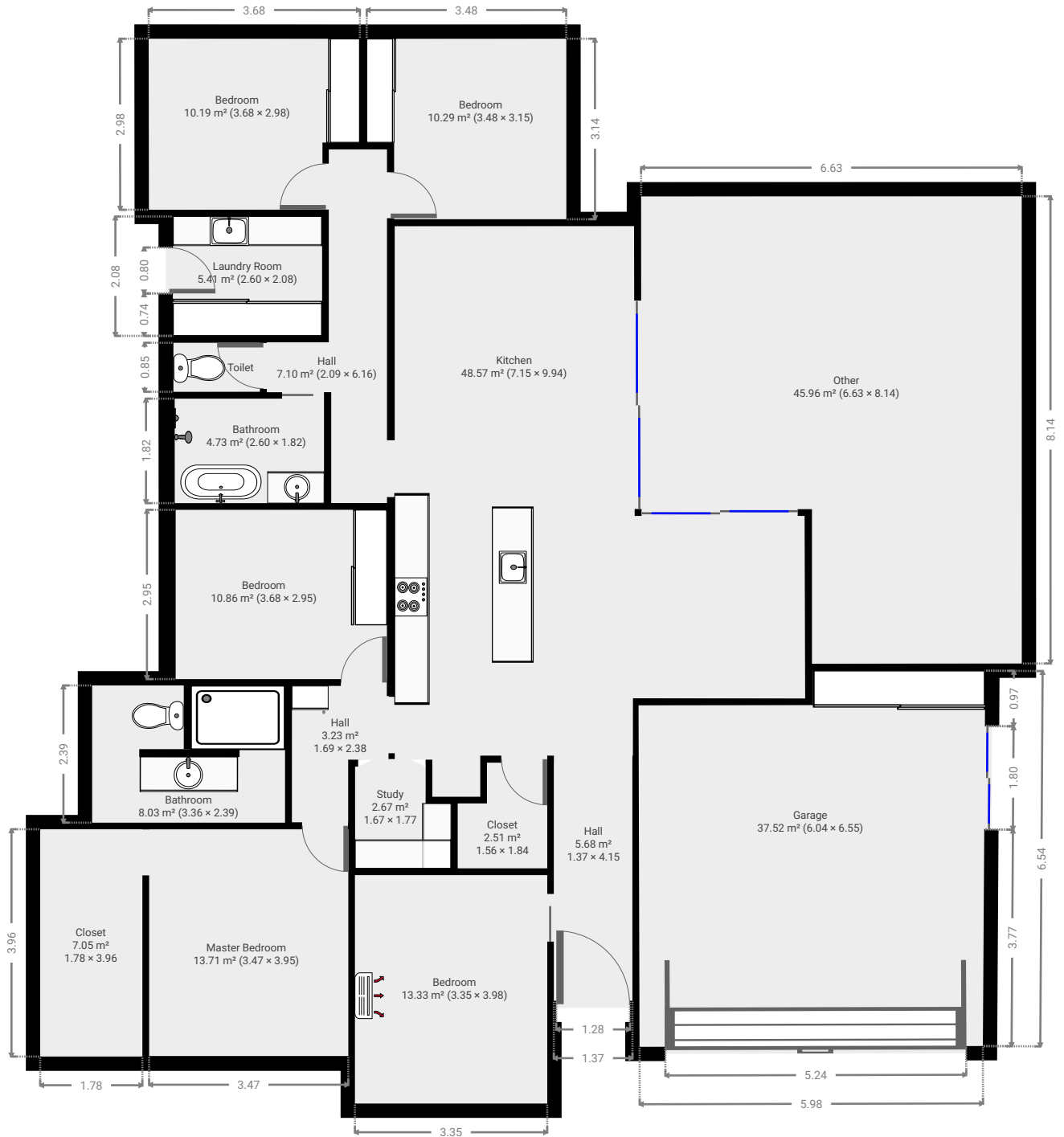

FLOORS: 1

▼ Closet Ground Floor

WIDTH: 1.78 m • LENGTH: 3.96 m
AREA: 7.05 m² • PERIMETER: 11.48 m

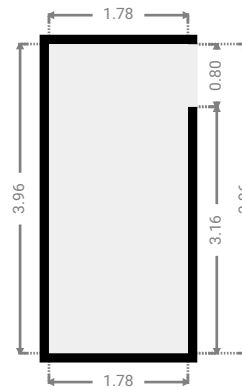
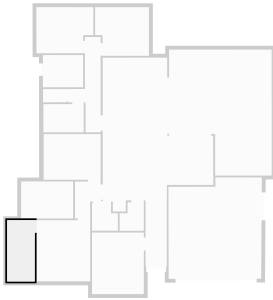

▼ Other Ground Floor

WIDTH: 6.63 m • LENGTH: 8.14 m
AREA: 45.96 m² • PERIMETER: 29.54 m

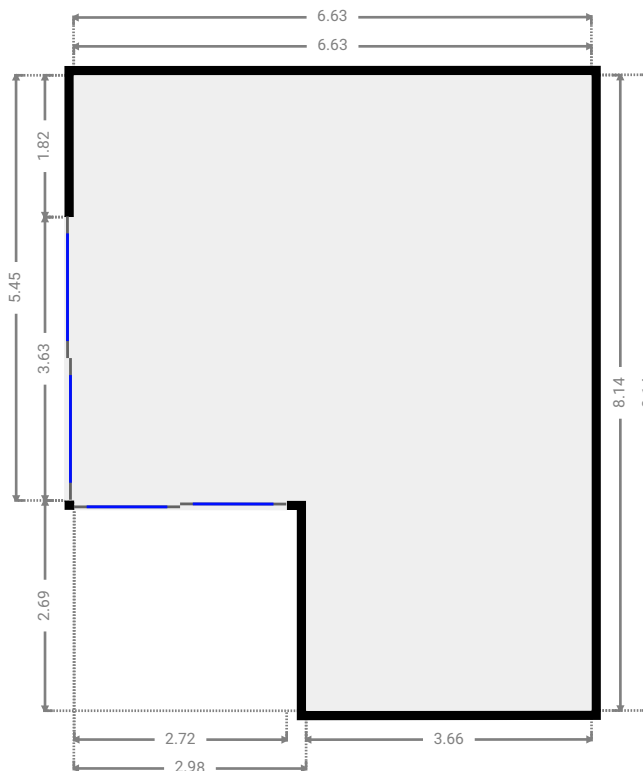
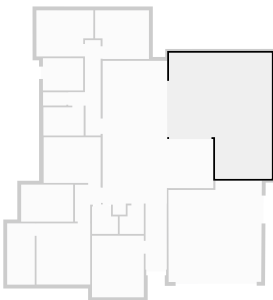

FLOORS: 1

▼ Bedroom Ground Floor

WIDTH: 3.48 m • LENGTH: 3.15 m
AREA: 10.29 m² • PERIMETER: 13.24 m

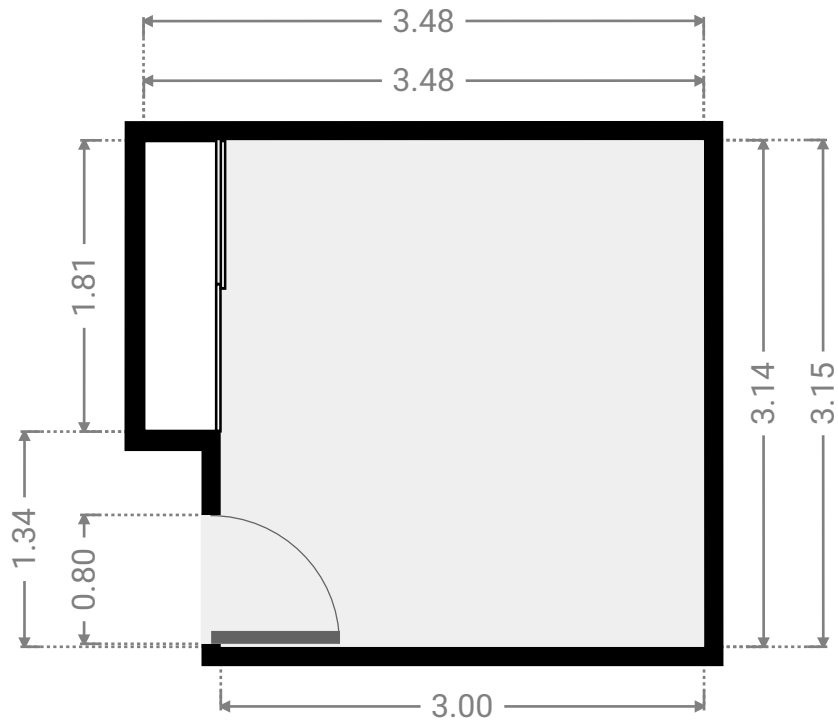
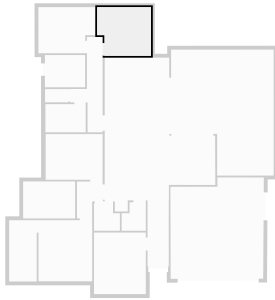

▼ Bedroom Ground Floor

WIDTH: 3.68 m • LENGTH: 2.98 m
AREA: 10.19 m² • PERIMETER: 13.31 m

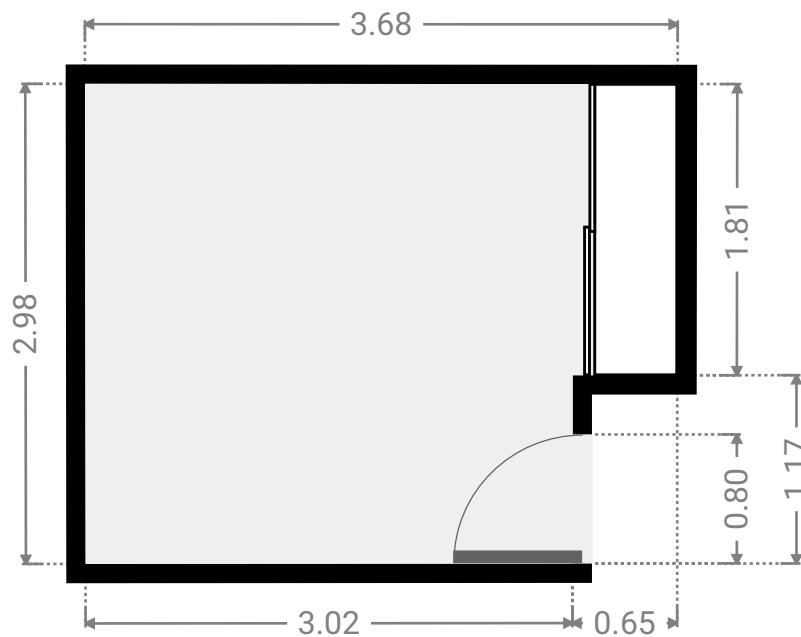
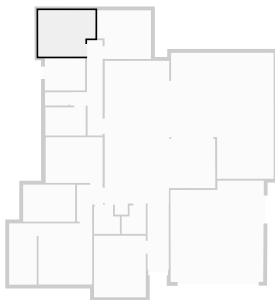

FLOORS: 1

▼ Laundry Room Ground Floor

WIDTH: 2.60 m • LENGTH: 2.08 m
AREA: 5.41 m² • PERIMETER: 9.36 m

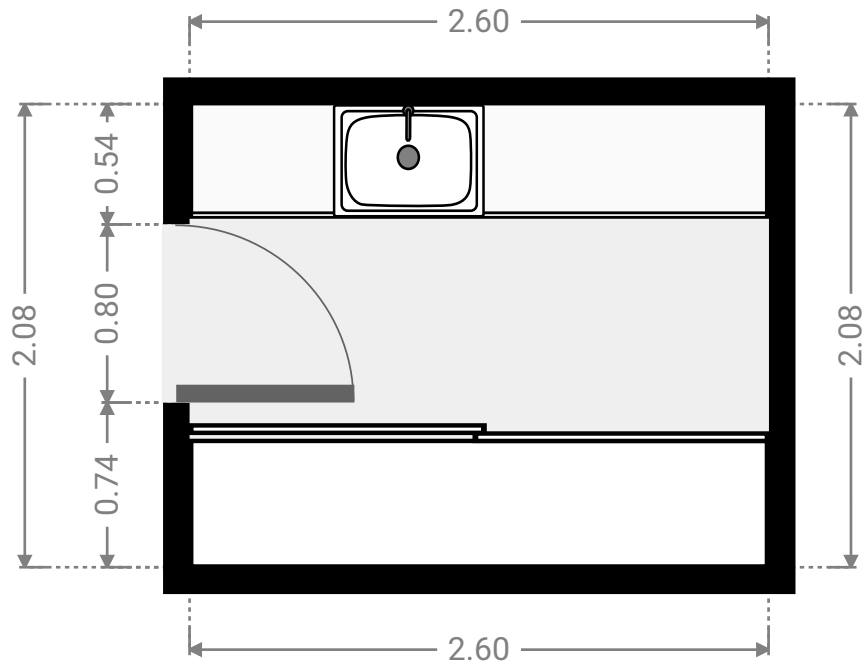
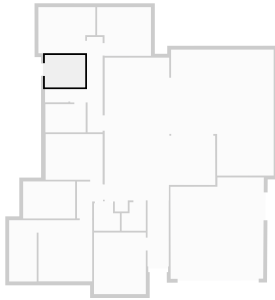

▼ Toilet Ground Floor

WIDTH: 1.51 m • LENGTH: 0.85 m
AREA: 1.29 m² • PERIMETER: 4.72 m

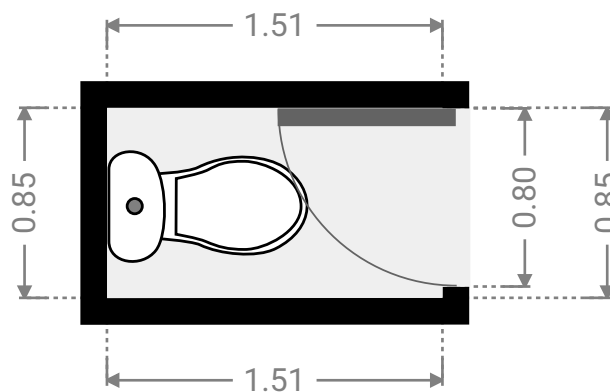

FLOORS: 1

▼ Bathroom Ground Floor

WIDTH: 2.60 m • LENGTH: 1.82 m
AREA: 4.73 m² • PERIMETER: 8.84 m

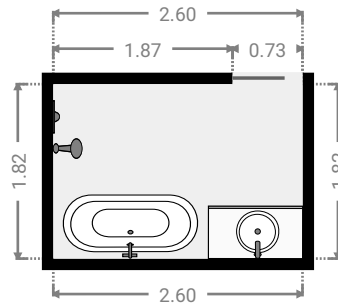
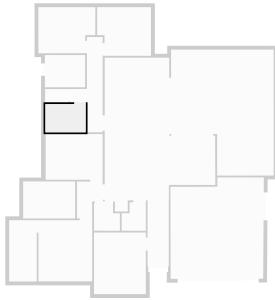

▼ Hall Ground Floor

WIDTH: 2.09 m • LENGTH: 6.16 m
AREA: 7.10 m² • PERIMETER: 16.51 m

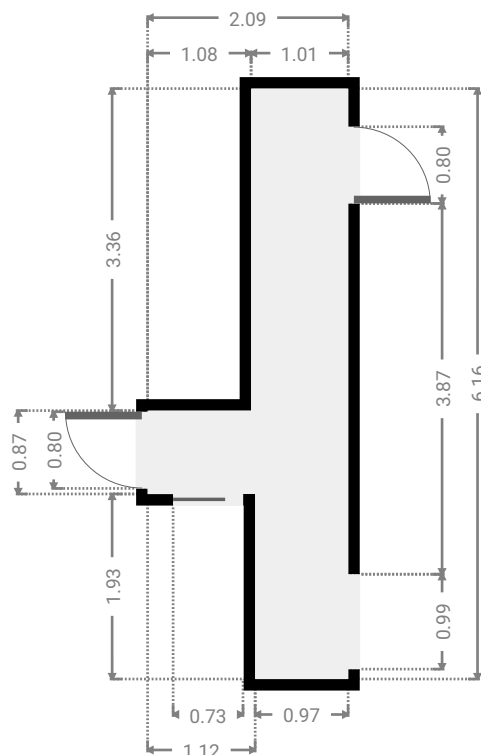
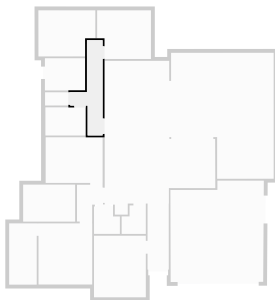

FLOORS: 1

▼ Bedroom Ground Floor

WIDTH: 3.68 m • LENGTH: 2.95 m
AREA: 10.86 m² • PERIMETER: 13.26 m

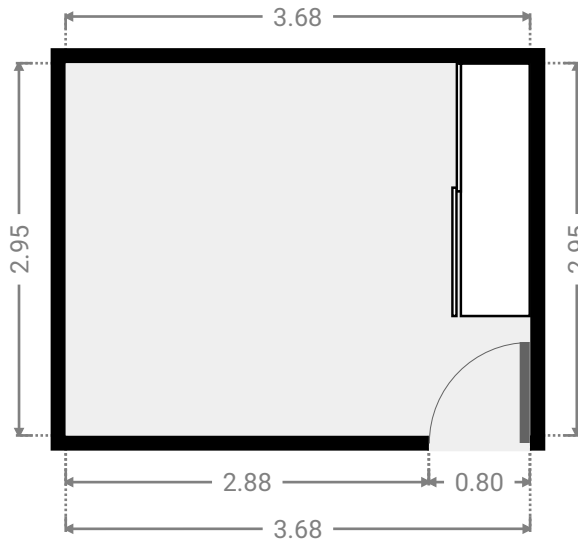
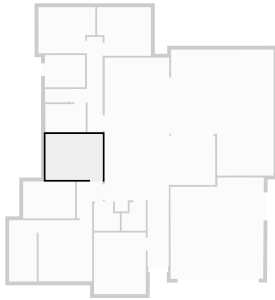

▼ Hall Ground Floor

WIDTH: 1.37 m • LENGTH: 4.15 m
AREA: 5.68 m² • PERIMETER: 11.04 m

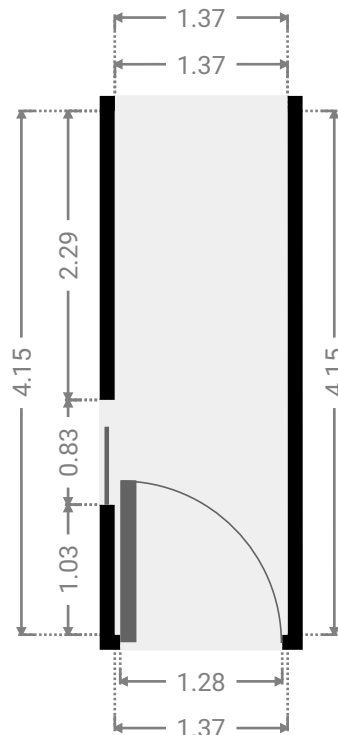

▼ Bathroom Ground Floor

WIDTH: 3.36 m • LENGTH: 2.39 m
AREA: 8.03 m² • PERIMETER: 11.50 m

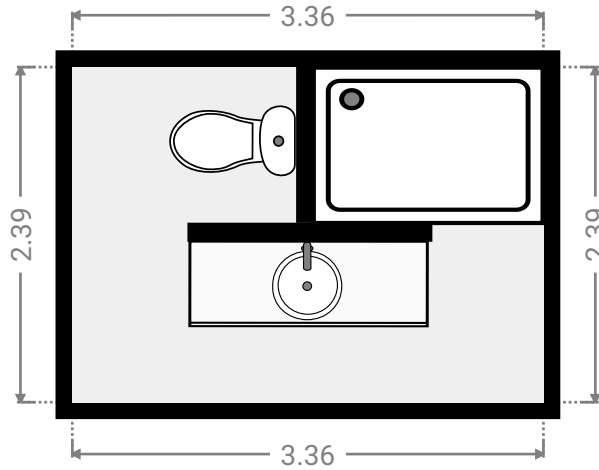
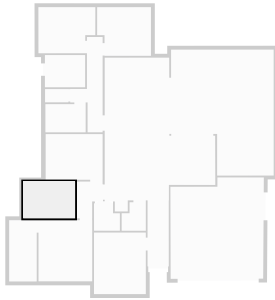

▼ Master Bedroom Ground Floor

WIDTH: 3.47 m • LENGTH: 3.95 m
AREA: 13.71 m² • PERIMETER: 14.84 m

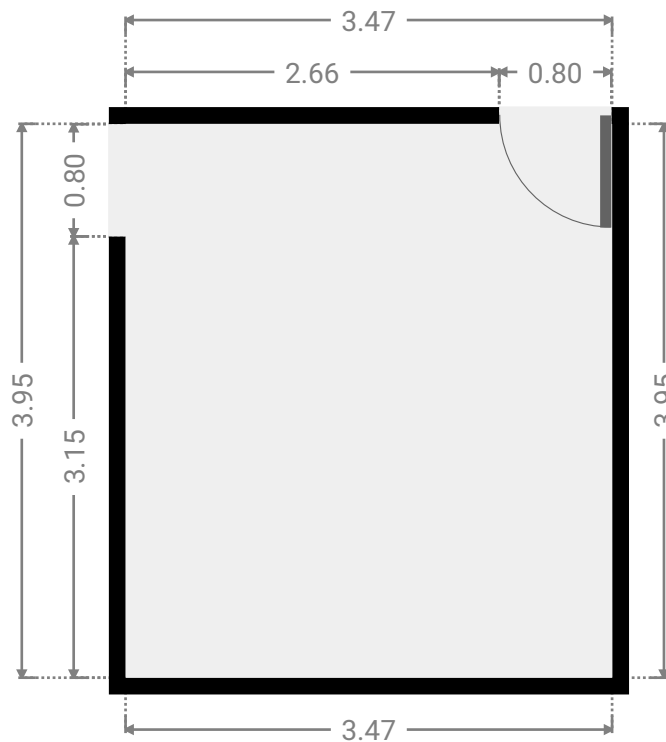

FLOORS: 1

▼ Hall Ground Floor

WIDTH: 1.69 m • LENGTH: 2.38 m
AREA: 3.23 m² • PERIMETER: 8.12 m

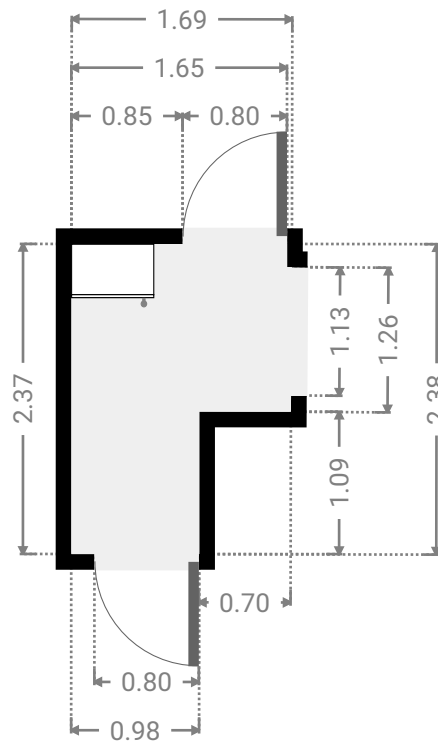
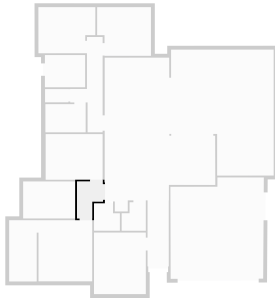

▼ Study Ground Floor

WIDTH: 1.67 m • LENGTH: 1.77 m
AREA: 2.67 m² • PERIMETER: 6.88 m

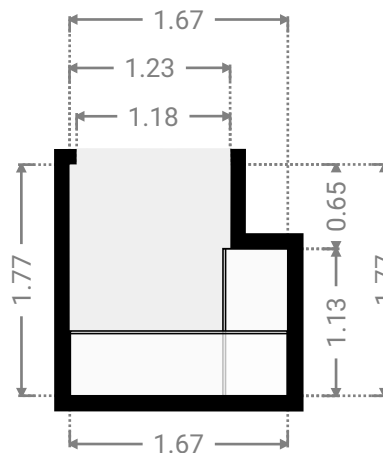
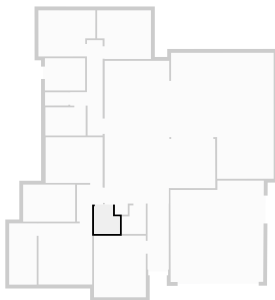

FLOORS: 1

▼ Closet Ground Floor

WIDTH: 1.56 m • LENGTH: 1.84 m
AREA: 2.51 m² • PERIMETER: 6.80 m

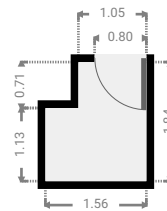
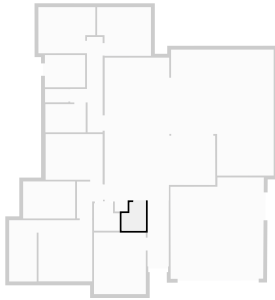

▼ Kitchen Ground Floor

WIDTH: 7.15 m • LENGTH: 9.94 m
AREA: 48.57 m² • PERIMETER: 34.16 m

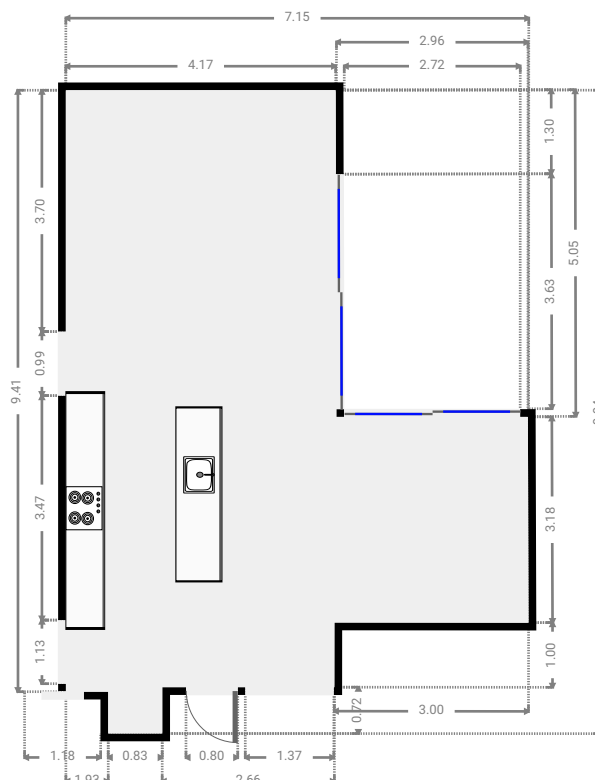
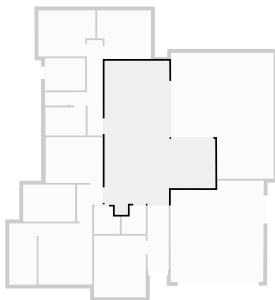

FLOORS: 1

▼ Garage Ground Floor

WIDTH: 6.04 m • LENGTH: 6.55 m
AREA: 37.52 m² • PERIMETER: 25.11 m

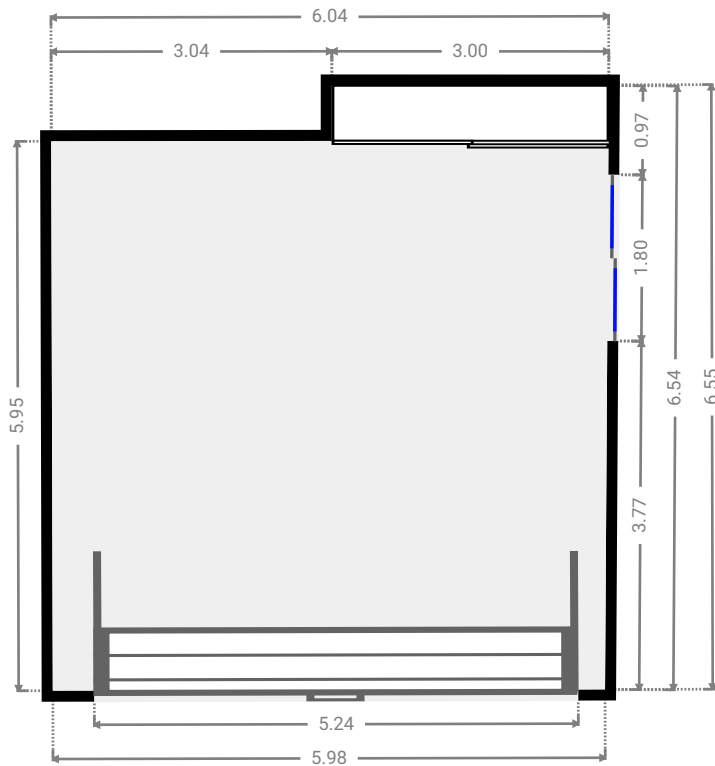
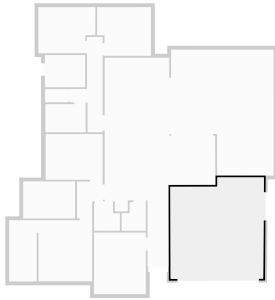

▼ Bedroom Ground Floor

WIDTH: 3.35 m • LENGTH: 3.98 m
AREA: 13.33 m² • PERIMETER: 14.66 m

