

2 Kerr Street

Created on
2021-02-02

Floors
2

▼ Ground Floor

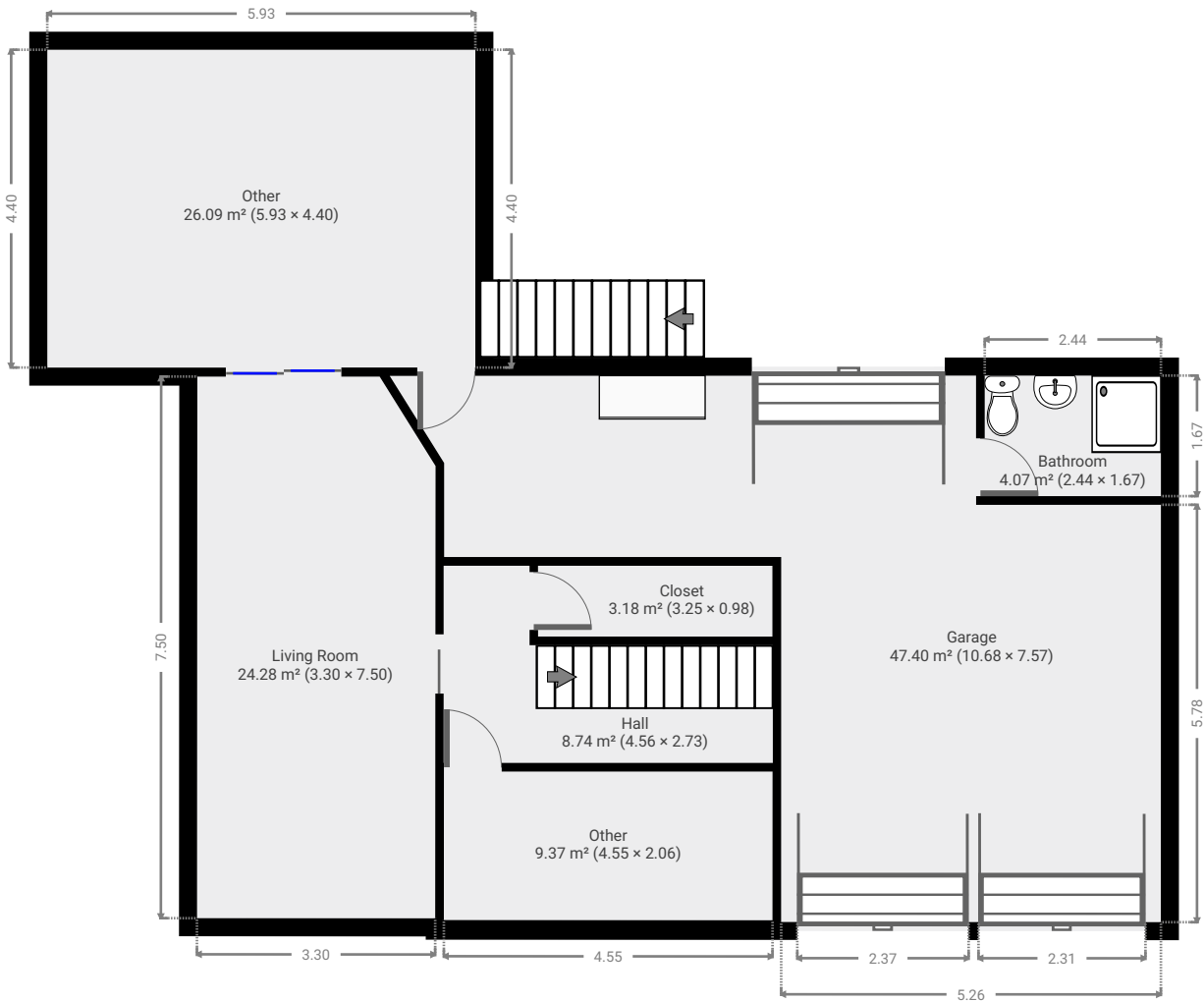
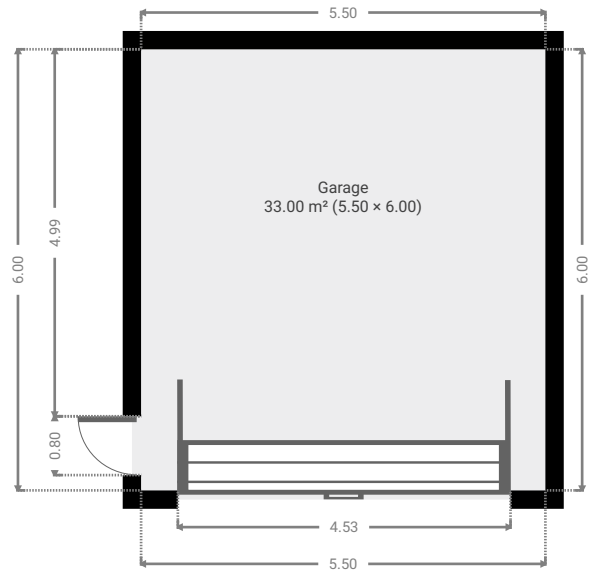

▼ Living Room
Ground Floor

WIDTH: 3.30 m • LENGTH: 7.50 m
AREA: 24.28 m² • PERIMETER: 21.05 m

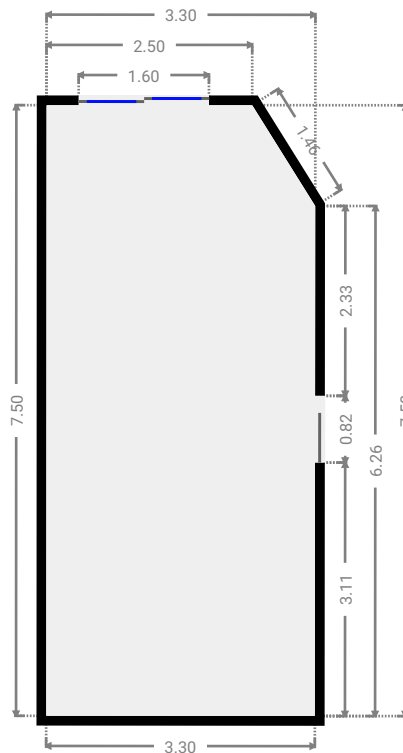
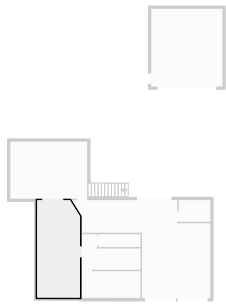

▼ Hall
Ground Floor

WIDTH: 4.56 m • LENGTH: 2.73 m
AREA: 8.74 m² • PERIMETER: 14.58 m

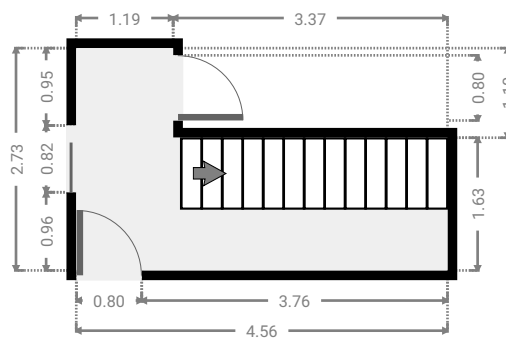
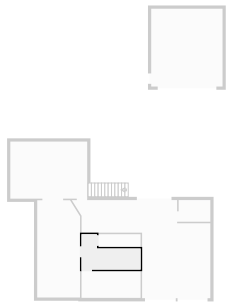

▼ **Closet**
Ground Floor

WIDTH: 3.25 m • LENGTH: 0.98 m
AREA: 3.18 m² • PERIMETER: 8.45 m

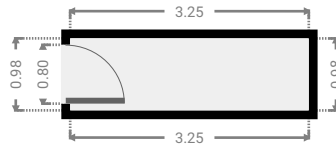
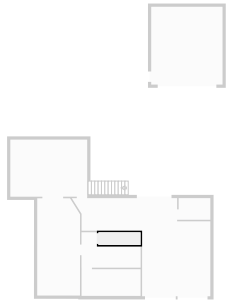

▼ **Garage**
Ground Floor

WIDTH: 10.68 m • LENGTH: 7.57 m
AREA: 47.40 m² • PERIMETER: 35.96 m

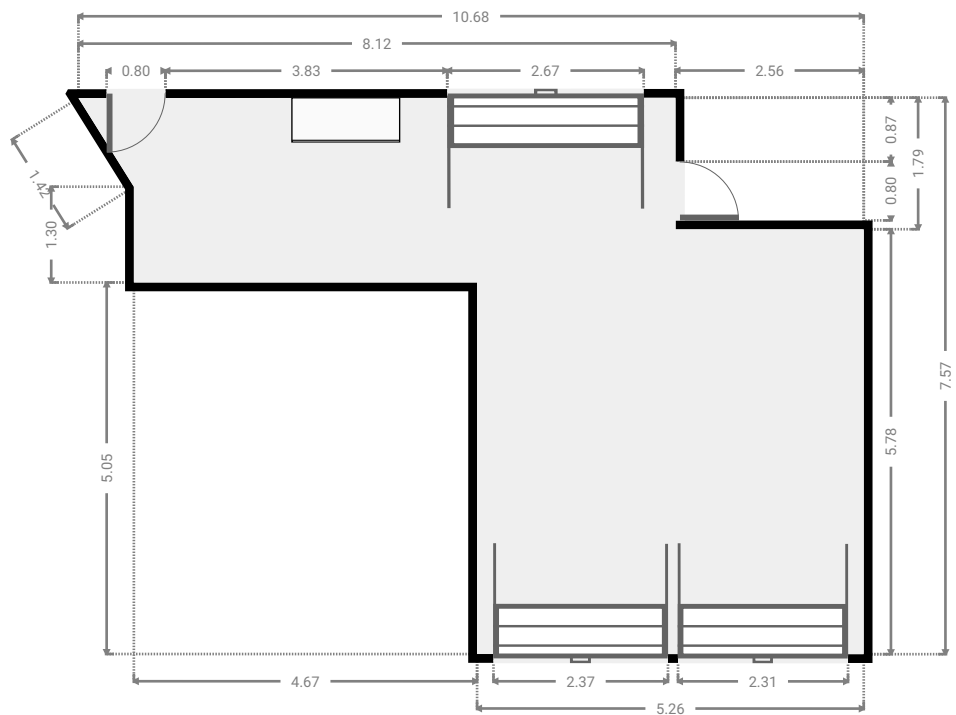
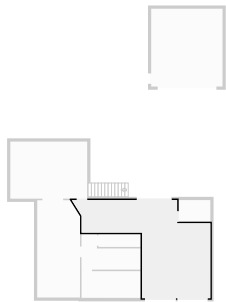

▼ Bathroom
Ground Floor

WIDTH: 2.44 m • LENGTH: 1.67 m
AREA: 4.07 m² • PERIMETER: 8.22 m

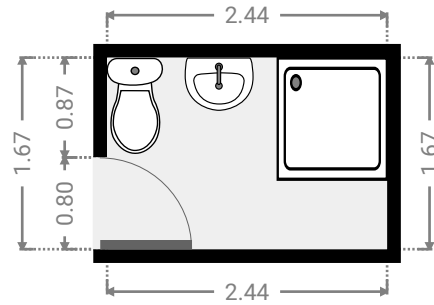
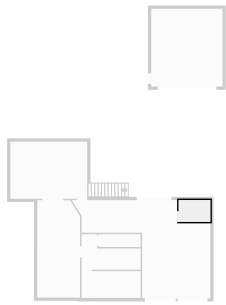

▼ Other
Ground Floor

WIDTH: 5.93 m • LENGTH: 4.40 m
AREA: 26.09 m² • PERIMETER: 20.66 m

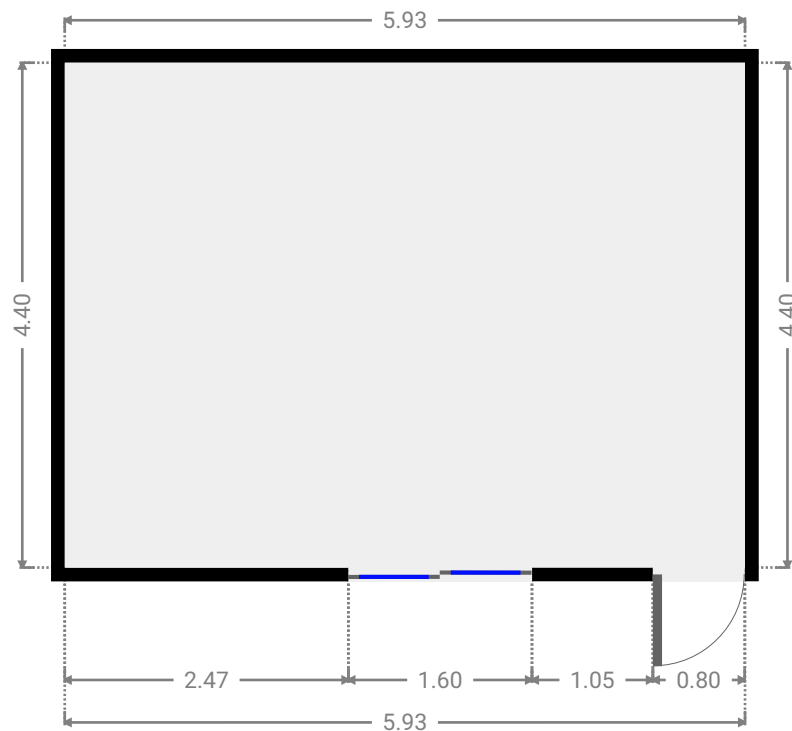
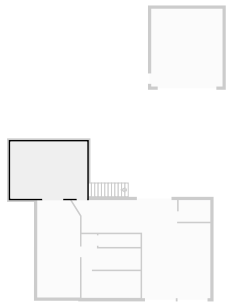

▼ Other
Ground Floor

WIDTH: 4.55 m • LENGTH: 2.06 m
AREA: 9.37 m² • PERIMETER: 13.22 m

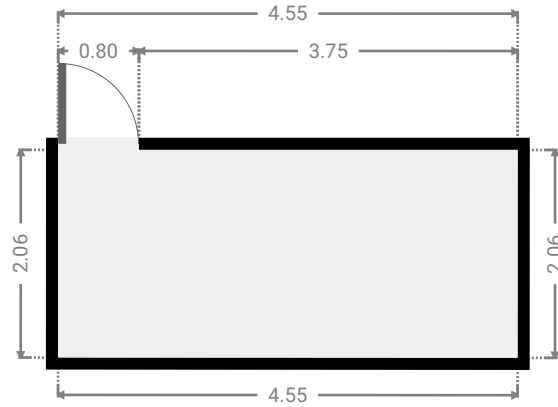
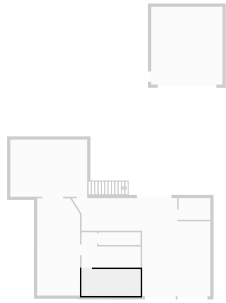

▼ Garage
Ground Floor

WIDTH: 5.50 m • LENGTH: 6.00 m
AREA: 33.00 m² • PERIMETER: 23.00 m

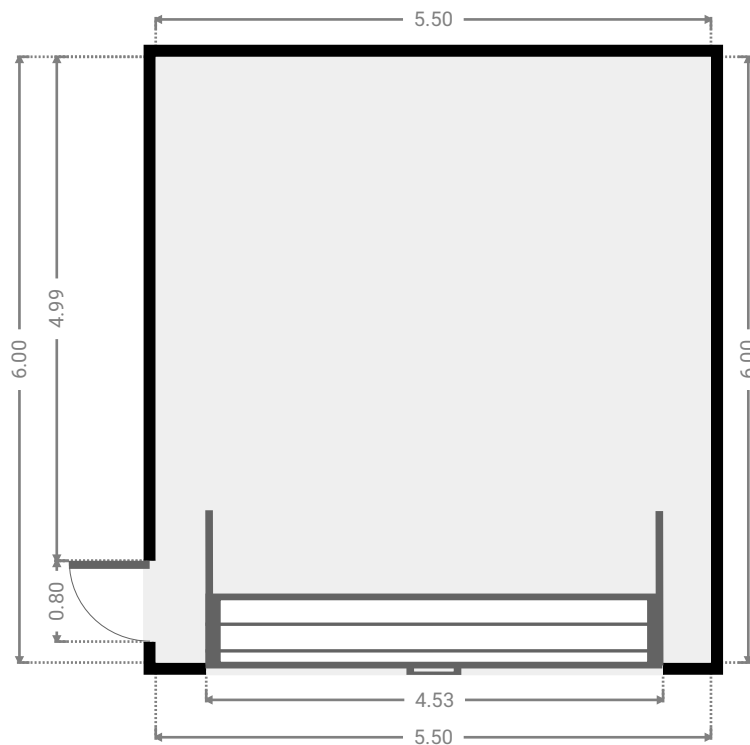
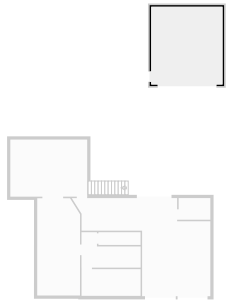

▼ 1st Floor

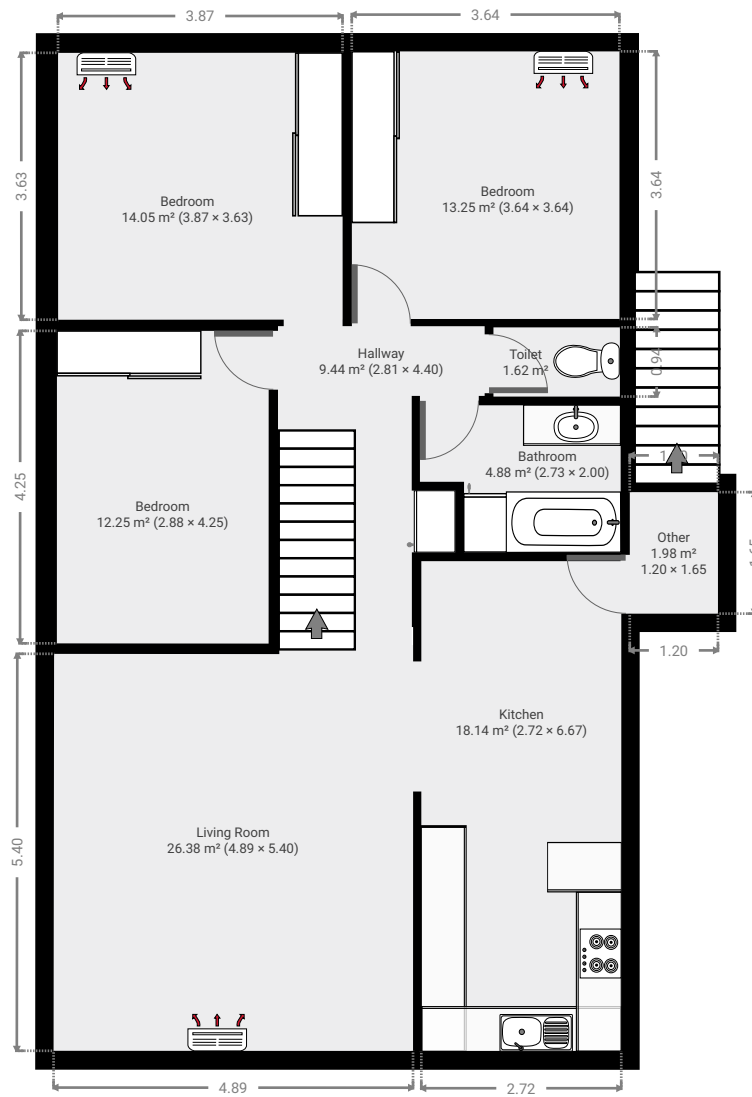

▼ Living Room
1st Floor

WIDTH: 5.40 m • LENGTH: 4.89 m
AREA: 26.38 m² • PERIMETER: 20.57 m

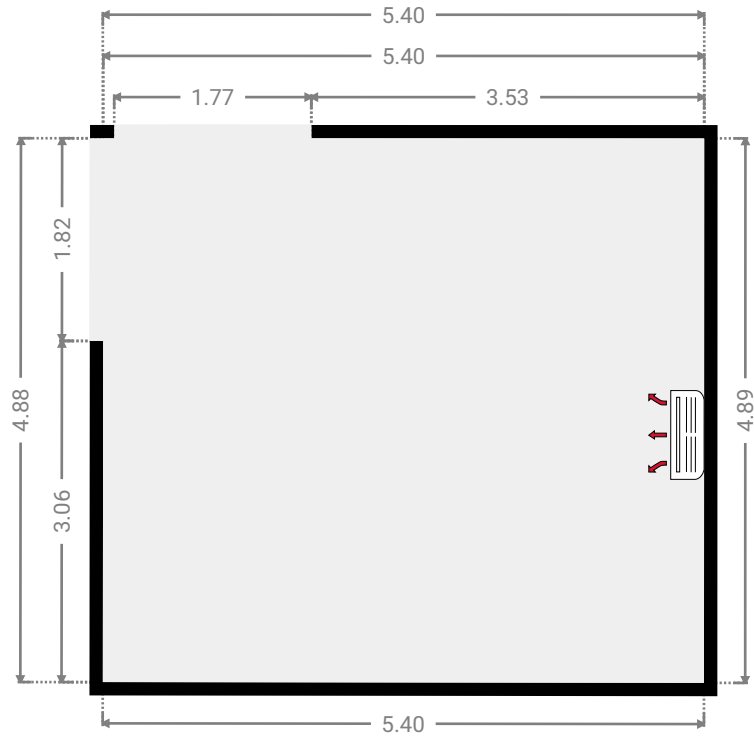
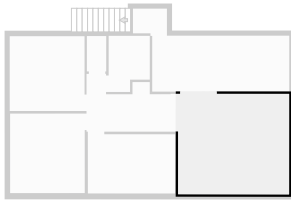

▼ Hallway
1st Floor

WIDTH: 4.40 m • LENGTH: 2.81 m
AREA: 9.44 m² • PERIMETER: 15.60 m

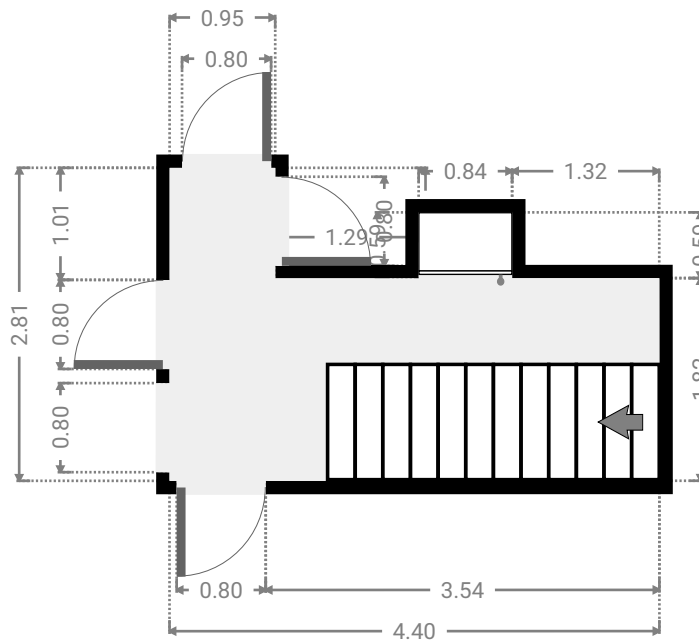
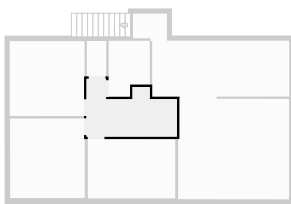

▼ Kitchen
1st Floor

WIDTH: 6.67 m • LENGTH: 2.72 m
AREA: 18.14 m² • PERIMETER: 18.78 m

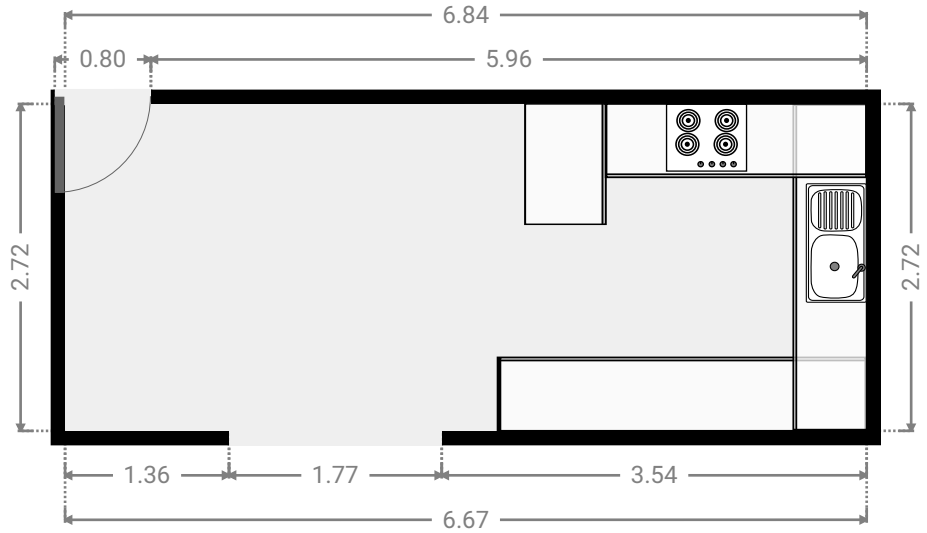
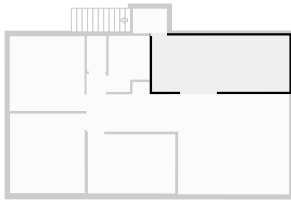

▼ Bedroom
1st Floor

WIDTH: 4.25 m • LENGTH: 2.88 m
AREA: 12.25 m² • PERIMETER: 14.26 m

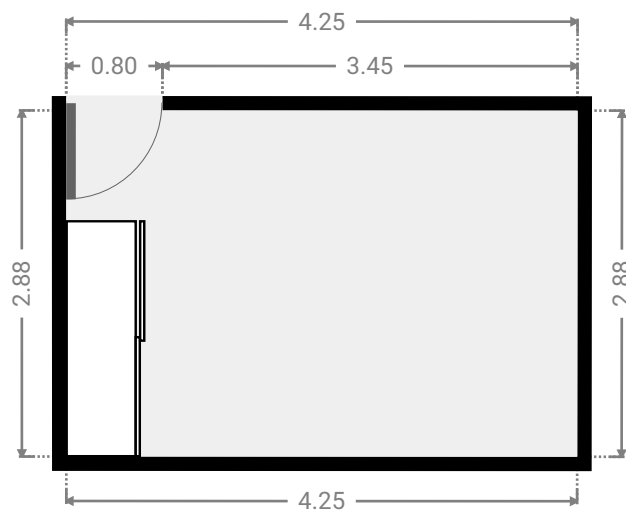
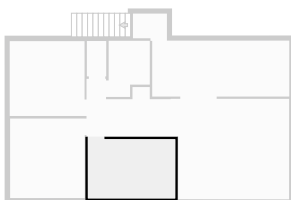

▼ **Bedroom**
1st Floor

WIDTH: 3.63 m • LENGTH: 3.87 m
AREA: 14.05 m² • PERIMETER: 15.00 m

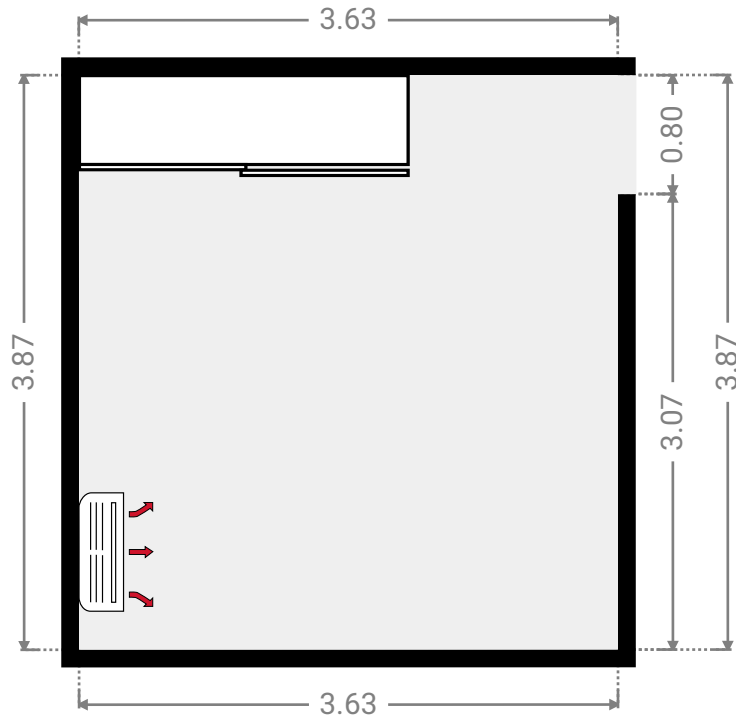
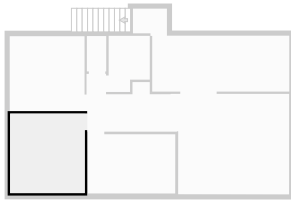

▼ **Bedroom**
1st Floor

WIDTH: 3.64 m • LENGTH: 3.64 m
AREA: 13.25 m² • PERIMETER: 14.56 m

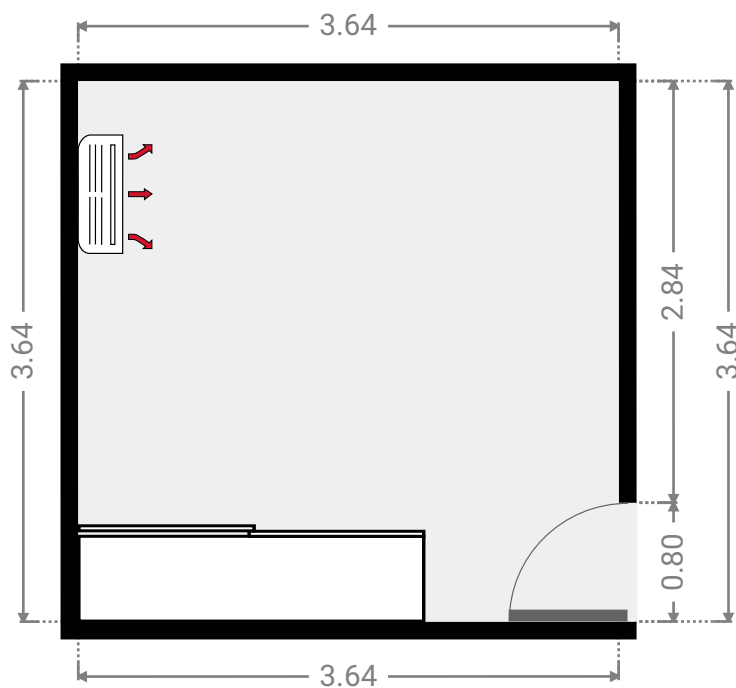
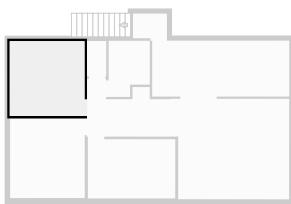

▼ **Bathroom**
1st Floor

WIDTH: 2.00 m • LENGTH: 2.73 m
AREA: 4.88 m² • PERIMETER: 9.46 m

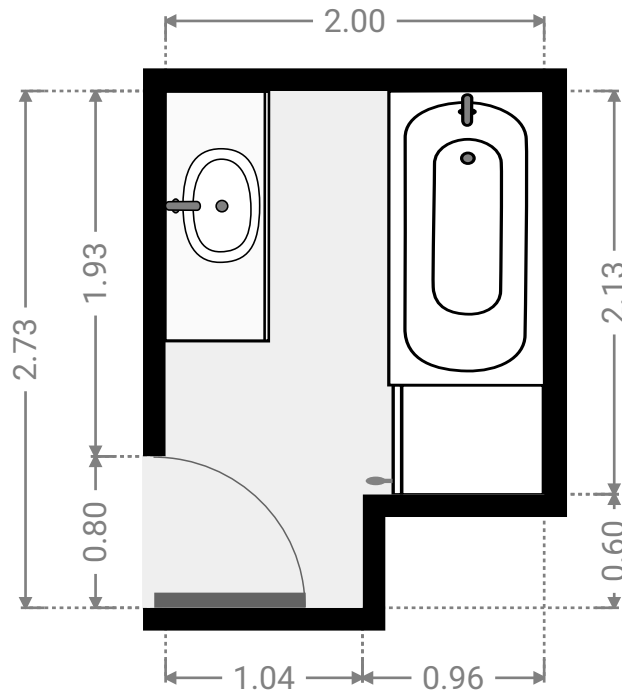
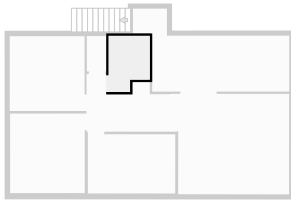

▼ **Toilet**
1st Floor

WIDTH: 0.94 m • LENGTH: 1.72 m
AREA: 1.62 m² • PERIMETER: 5.32 m

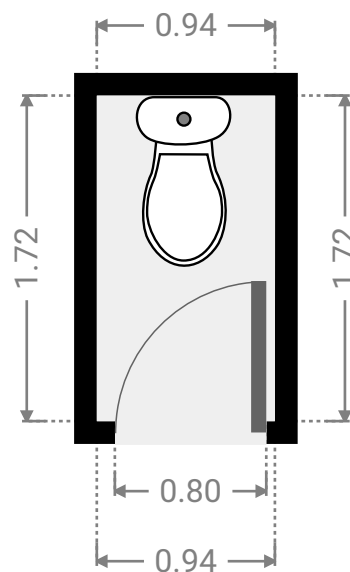
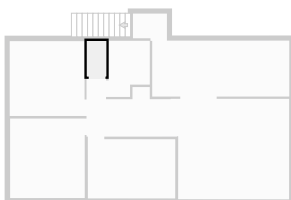

▼ Other
1st Floor

WIDTH: 1.65 m • LENGTH: 1.20 m
AREA: 1.98 m² • PERIMETER: 5.71 m

