

# 2 Auckland Street, Yaamba

**SUBMITTED BY**  
Ray White Rockhampton Casey  
stockers@cqoz.com

---

**CREATED ON**  
2022-02-09

---

**Floors**  
2

---

## ▼ Ground Floor

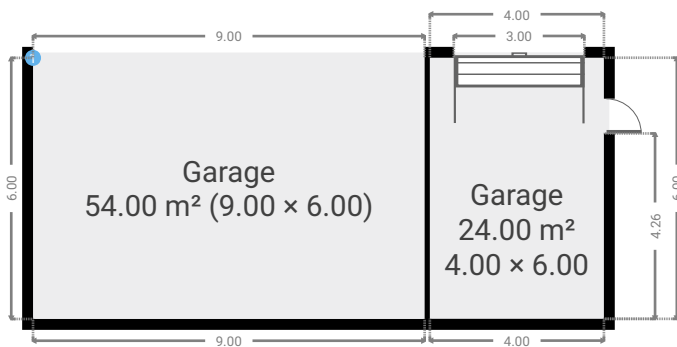
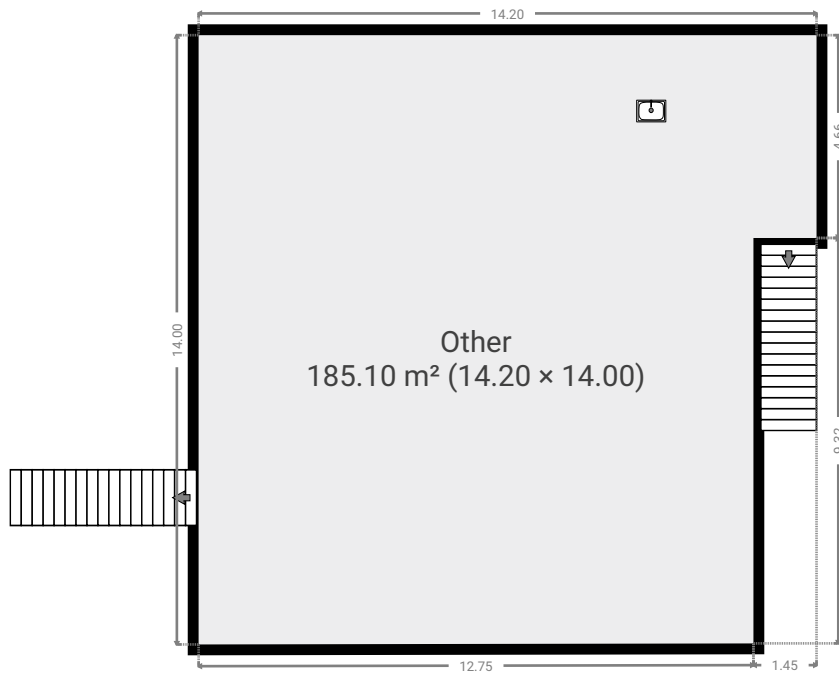

FLOORS: 2

▼ **Other**  
Ground Floor

WIDTH: 14.00 m • LENGTH: 14.20 m  
AREA: 185.10 m<sup>2</sup> • PERIMETER: 56.38 m

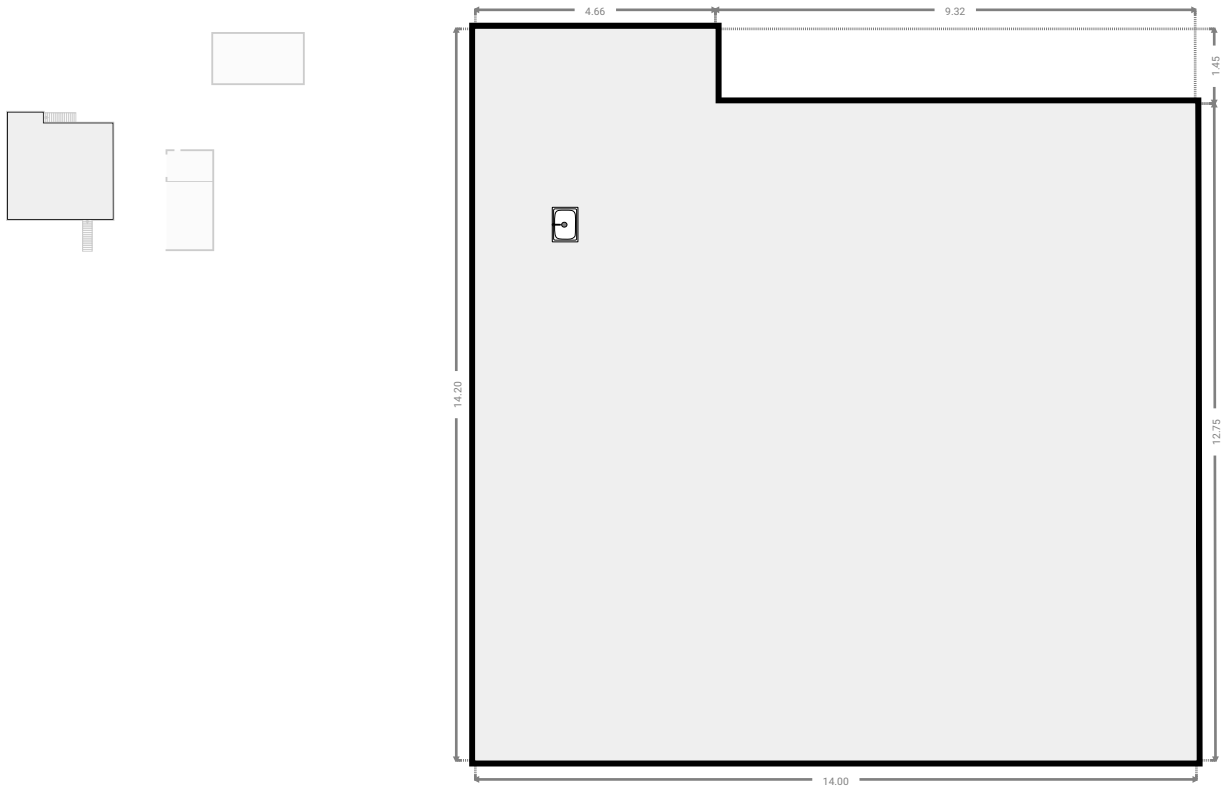

▼ **Garage**  
Ground Floor

WIDTH: 6.00 m • LENGTH: 9.00 m  
AREA: 54.00 m<sup>2</sup> • PERIMETER: 30.00 m

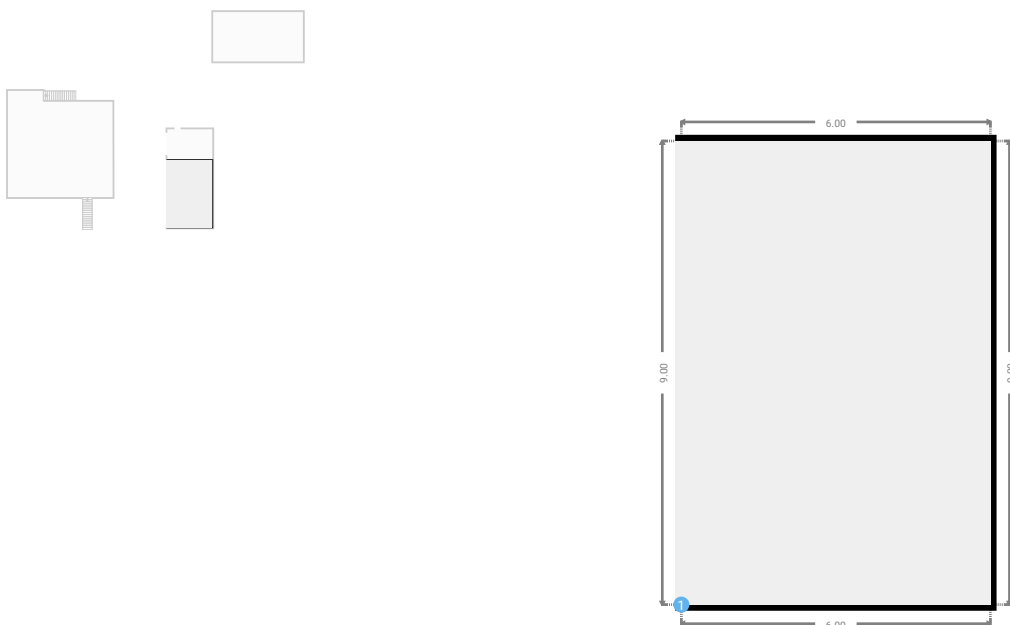

## ▼ Garage/Ground Floor

### 1 OPENING

Height  
0.00 m



FLOORS: 2

▼ **Garage**  
Ground Floor

WIDTH: 6.00 m • LENGTH: 4.00 m  
AREA: 24.00 m<sup>2</sup> • PERIMETER: 20.00 m

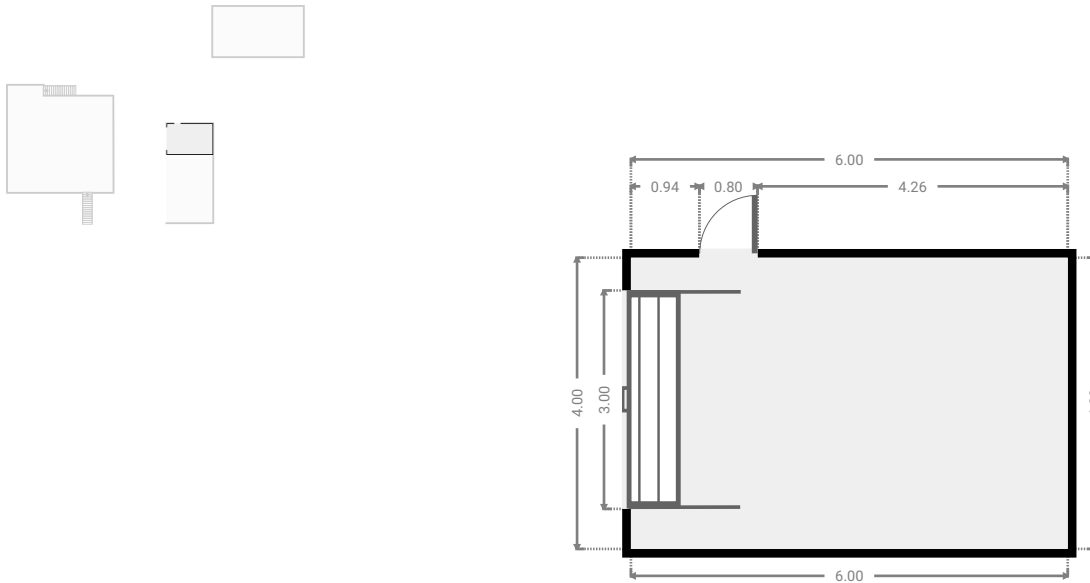

▼ **Other**  
Ground Floor

WIDTH: 12.00 m • LENGTH: 6.60 m  
AREA: 79.20 m<sup>2</sup> • PERIMETER: 37.20 m

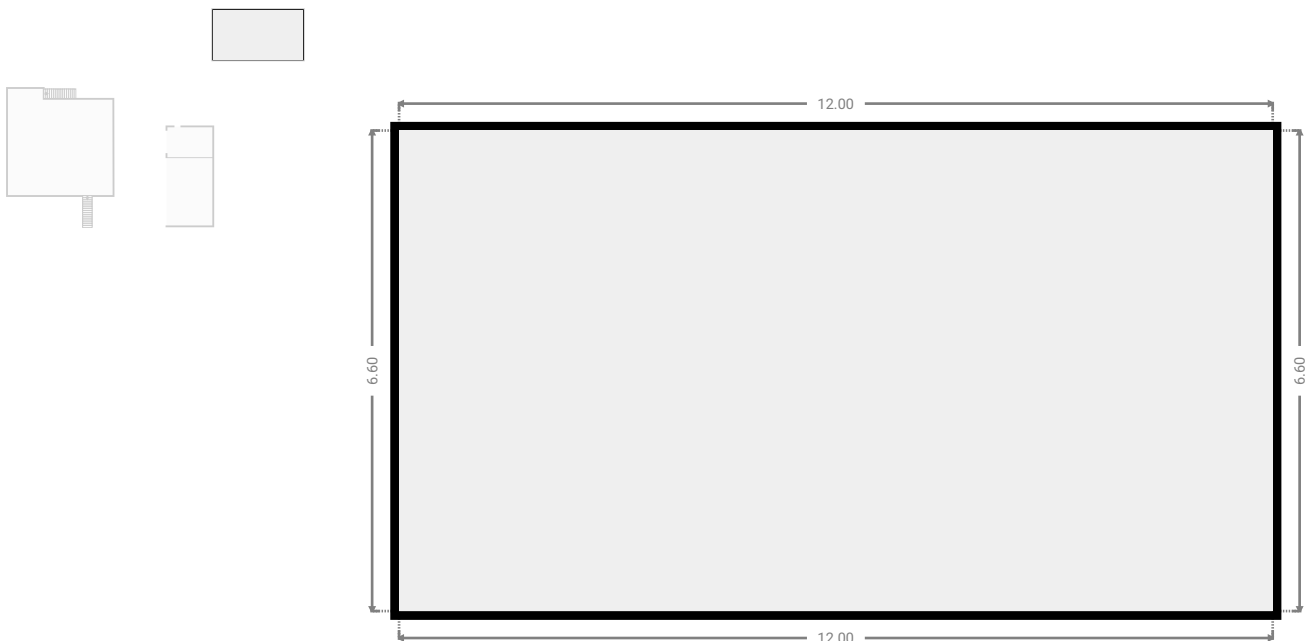

## ▼ 1st Floor

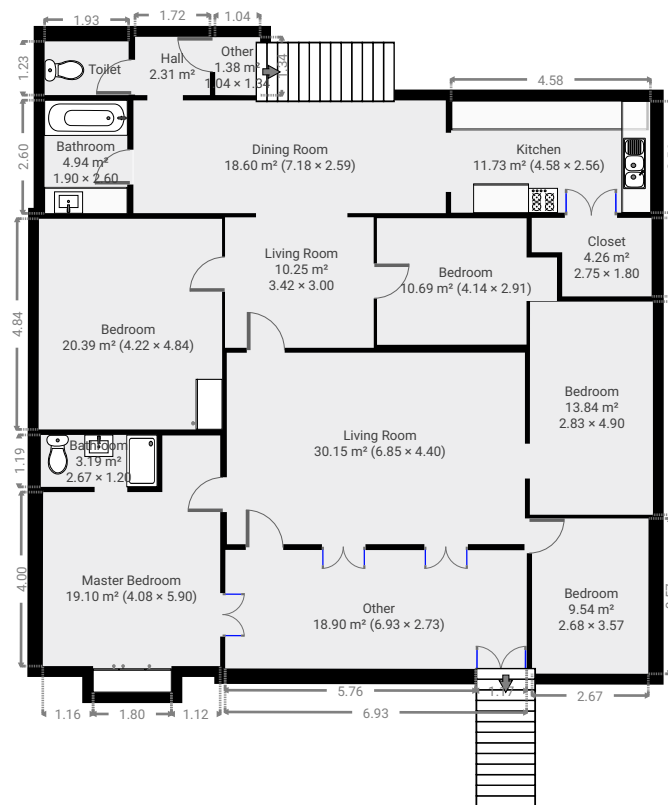

FLOORS: 2

## ▼ Other 1st Floor

WIDTH: 6.93 m • LENGTH: 2.73 m  
AREA: 18.90 m<sup>2</sup> • PERIMETER: 19.31 m

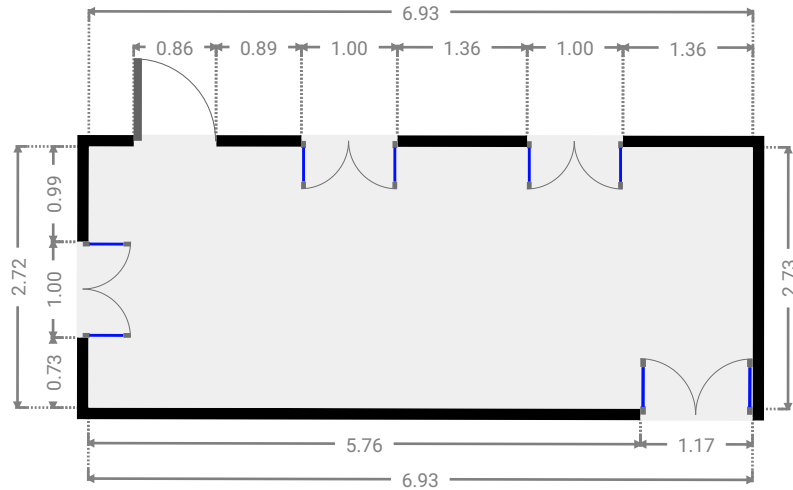
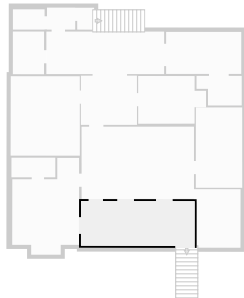

## ▼ Living Room 1st Floor

WIDTH: 6.85 m • LENGTH: 4.40 m  
AREA: 30.15 m<sup>2</sup> • PERIMETER: 22.50 m

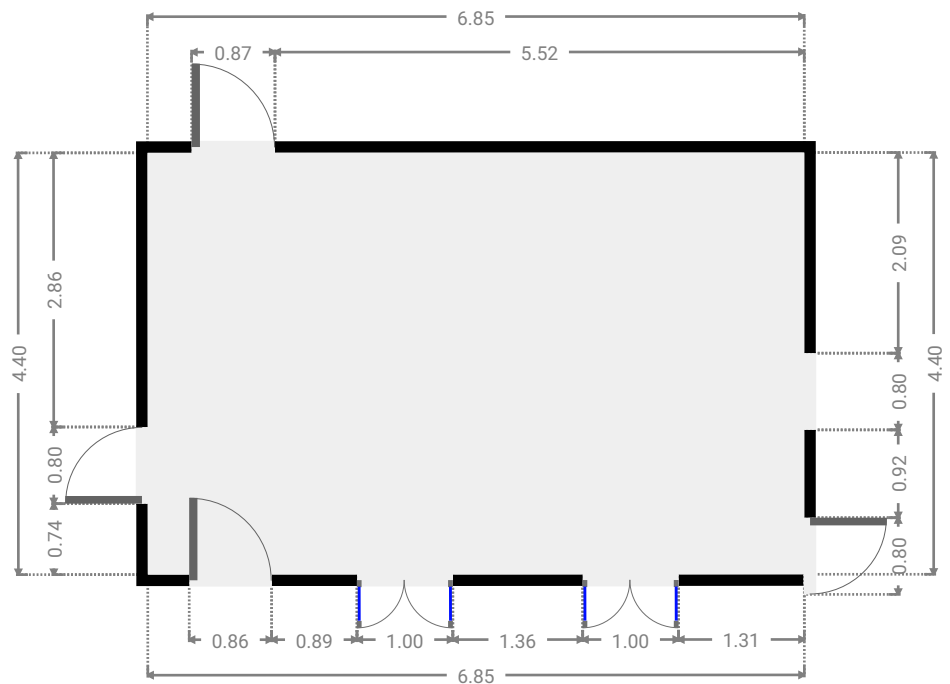
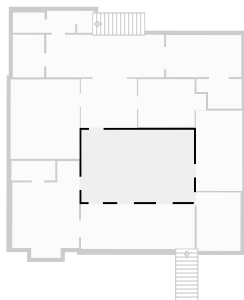

FLOORS: 2

▼ **Bedroom**  
1st Floor

WIDTH: 2.68 m • LENGTH: 3.57 m  
AREA: 9.54 m<sup>2</sup> • PERIMETER: 12.48 m

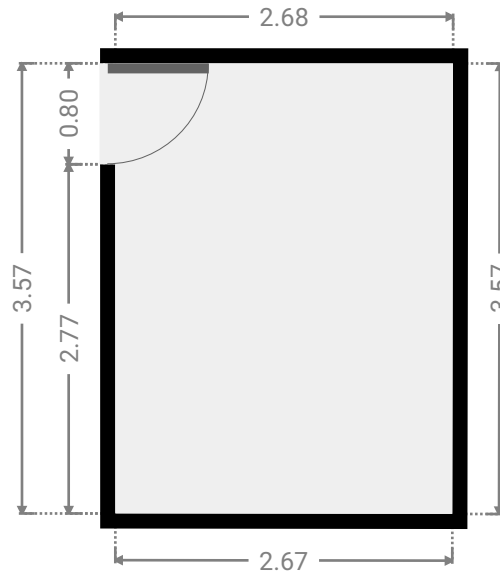
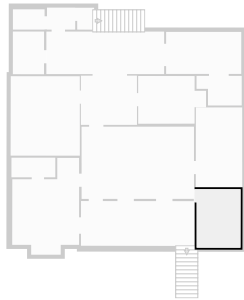

▼ **Bedroom**  
1st Floor

WIDTH: 2.83 m • LENGTH: 4.90 m  
AREA: 13.84 m<sup>2</sup> • PERIMETER: 15.45 m

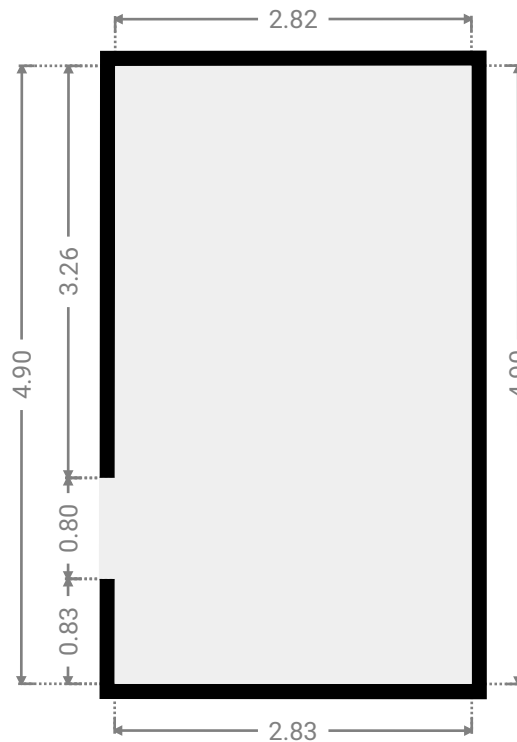
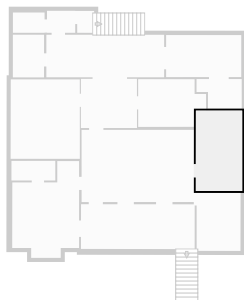



▼ **Master Bedroom**  
1st Floor

WIDTH: 4.08 m • LENGTH: 5.90 m  
AREA: 19.10 m<sup>2</sup> • PERIMETER: 19.94 m

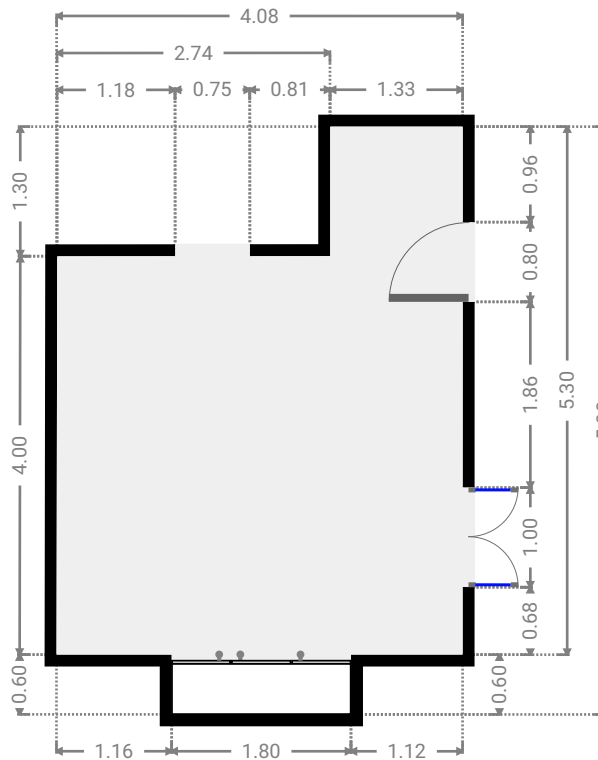
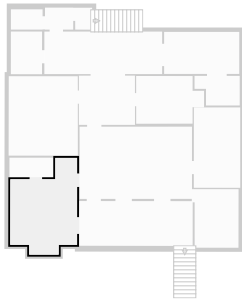

▼ **Bathroom**  
1st Floor

WIDTH: 2.67 m • LENGTH: 1.20 m  
AREA: 3.19 m<sup>2</sup> • PERIMETER: 7.73 m

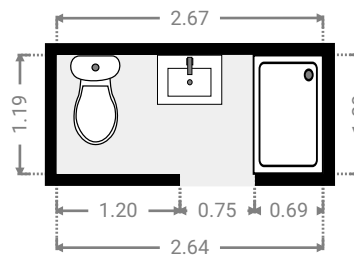
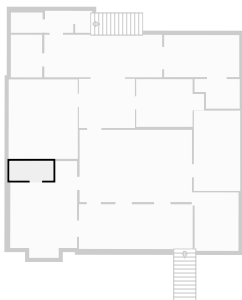

FLOORS: 2

▼ **Bedroom**  
1st Floor

WIDTH: 4.22 m • LENGTH: 4.84 m  
AREA: 20.39 m<sup>2</sup> • PERIMETER: 18.11 m

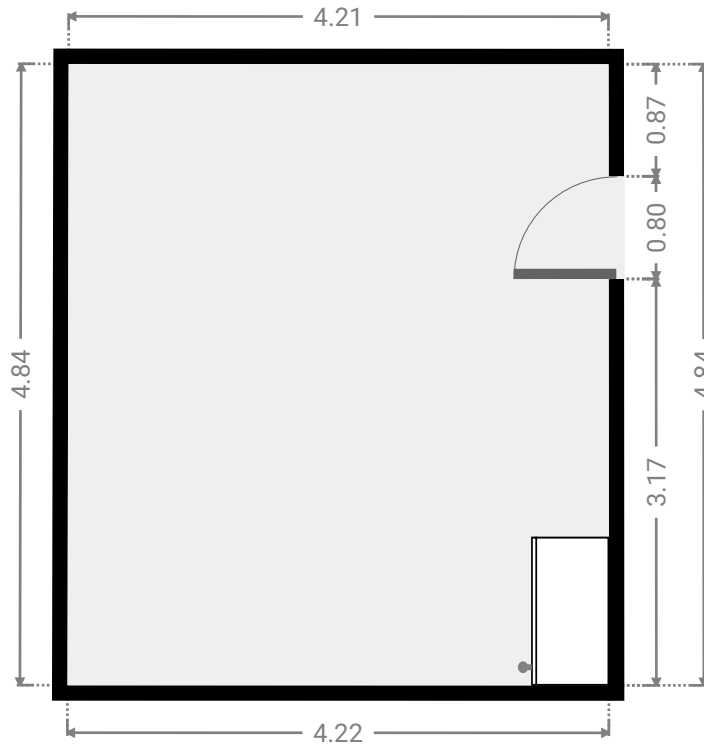
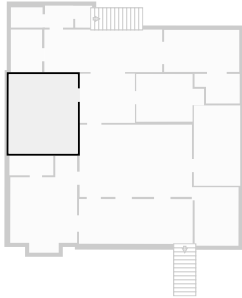

▼ **Living Room**  
1st Floor

WIDTH: 3.42 m • LENGTH: 3.00 m  
AREA: 10.25 m<sup>2</sup> • PERIMETER: 12.83 m

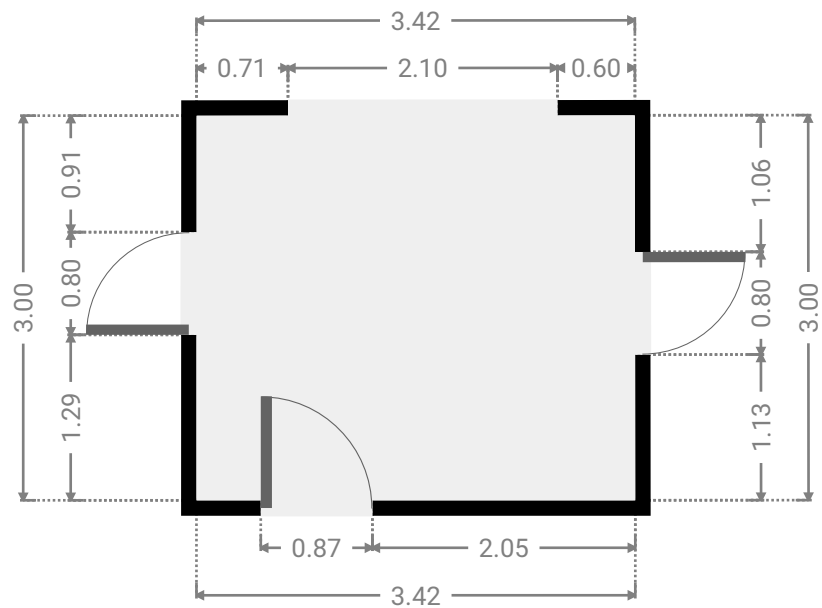
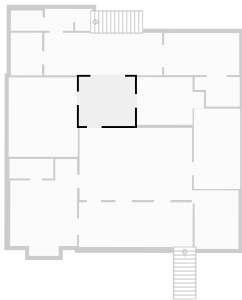

FLOORS: 2

▼ **Bedroom**  
1st Floor

WIDTH: 4.14 m • LENGTH: 2.91 m  
AREA: 10.69 m<sup>2</sup> • PERIMETER: 14.09 m

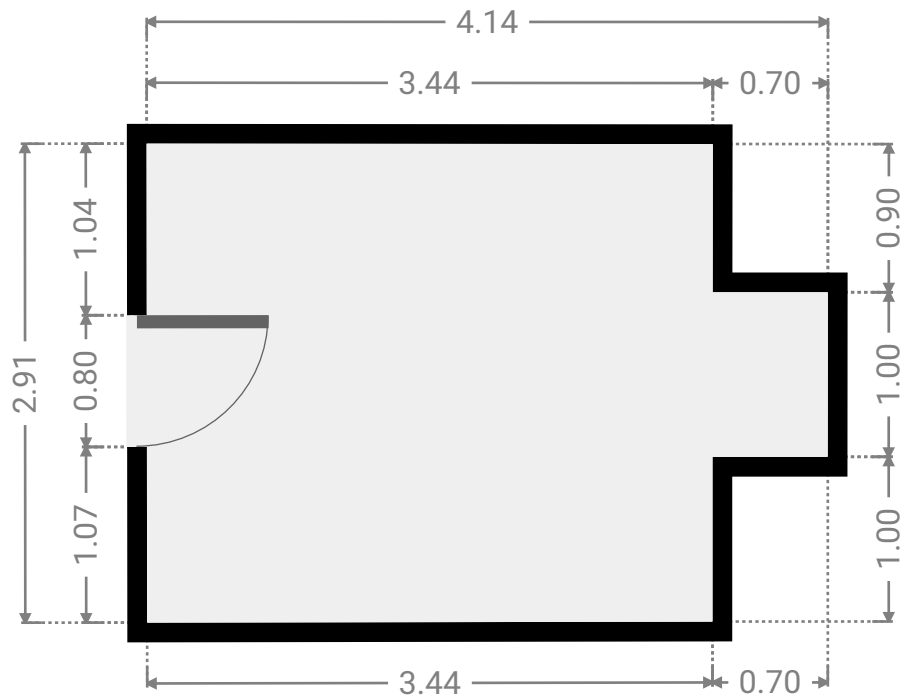
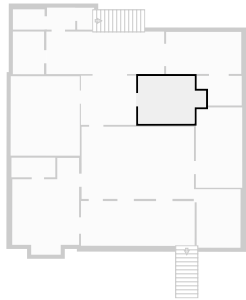

▼ **Bathroom**  
1st Floor

WIDTH: 1.90 m • LENGTH: 2.60 m  
AREA: 4.94 m<sup>2</sup> • PERIMETER: 9.00 m

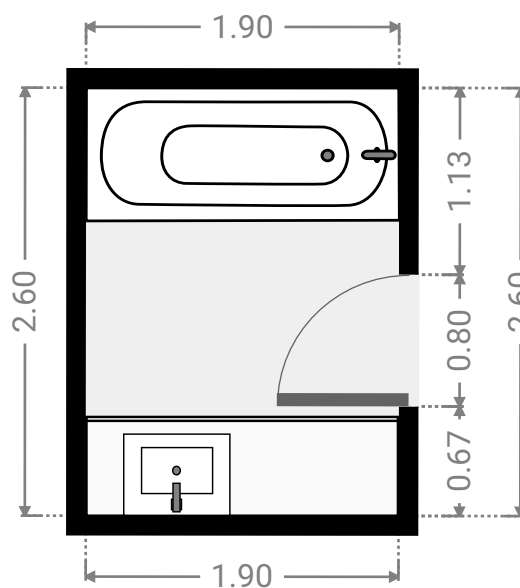
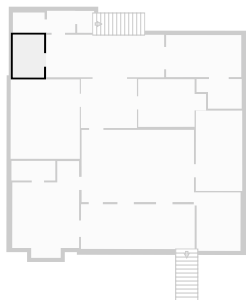

FLOORS: 2

▼ Dining Room  
1st Floor

WIDTH: 7.18 m • LENGTH: 2.59 m  
AREA: 18.60 m<sup>2</sup> • PERIMETER: 19.54 m

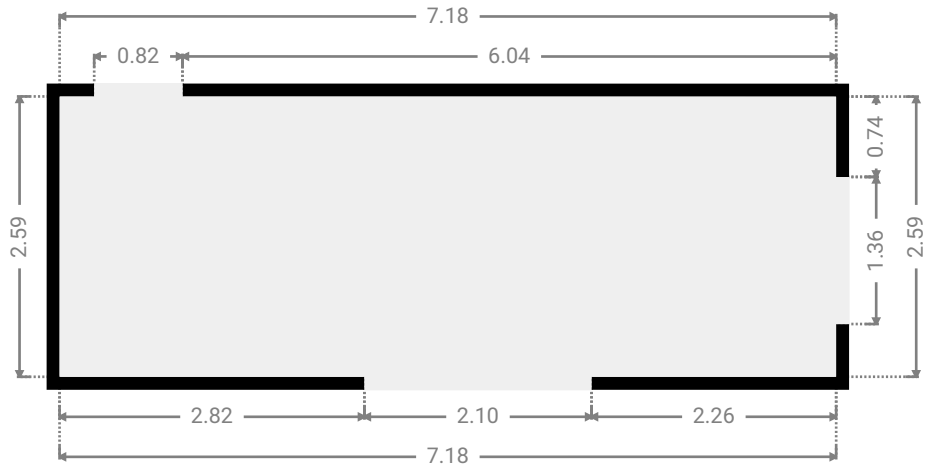
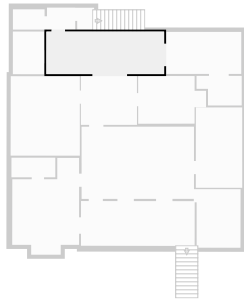

▼ Closet  
1st Floor

WIDTH: 2.75 m • LENGTH: 1.80 m  
AREA: 4.26 m<sup>2</sup> • PERIMETER: 9.11 m

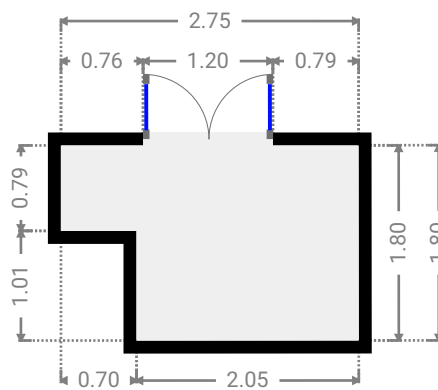
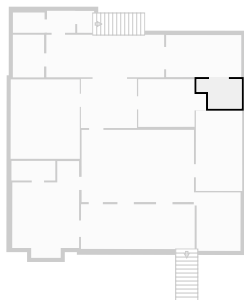

▼ **Kitchen**  
1st Floor

WIDTH: 4.58 m • LENGTH: 2.56 m  
AREA: 11.73 m<sup>2</sup> • PERIMETER: 14.28 m

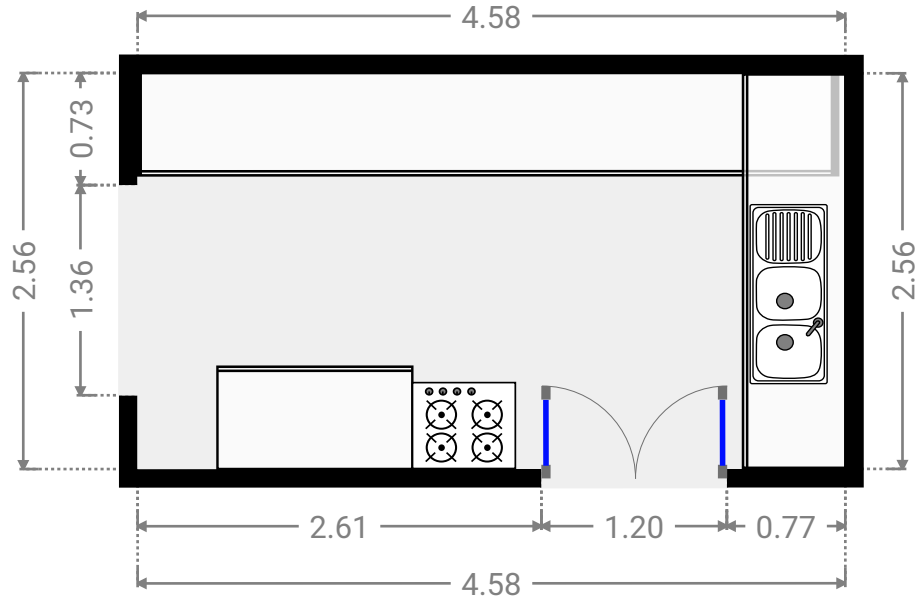
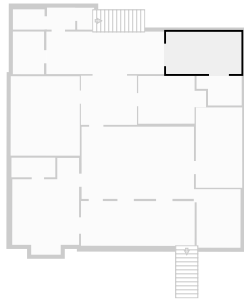

▼ **Hall**  
1st Floor

WIDTH: 1.72 m • LENGTH: 1.34 m  
AREA: 2.31 m<sup>2</sup> • PERIMETER: 6.12 m

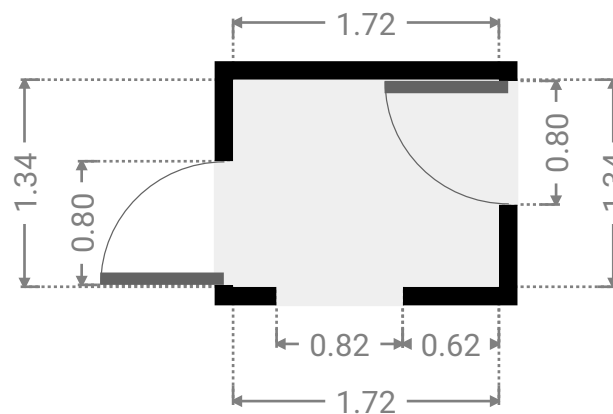
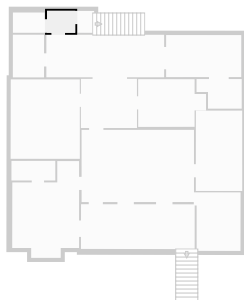

FLOORS: 2

▼ Toilet  
1st Floor

WIDTH: 1.93 m • LENGTH: 1.23 m  
AREA: 2.38 m<sup>2</sup> • PERIMETER: 6.33 m

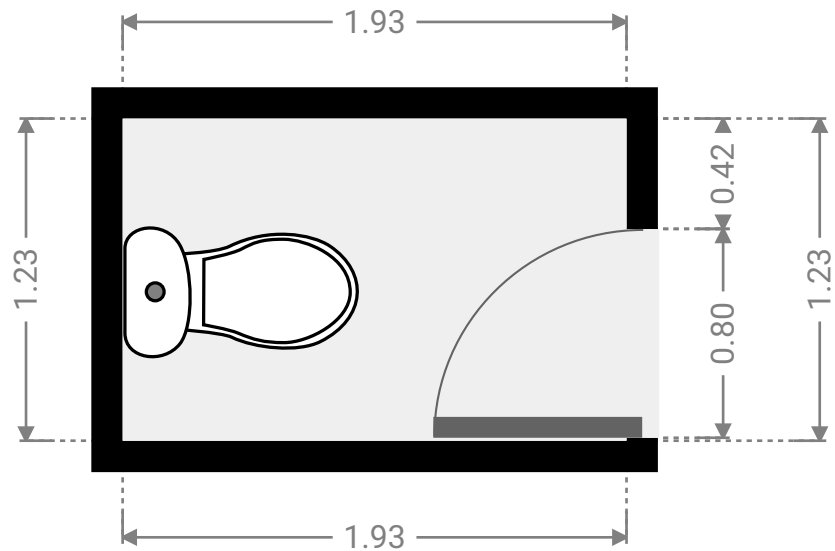
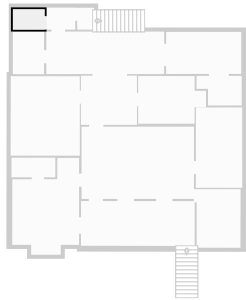

▼ Other  
1st Floor

WIDTH: 1.04 m • LENGTH: 1.34 m  
AREA: 1.38 m<sup>2</sup> • PERIMETER: 4.73 m

