

2/93-95 Pennyquick Street

SUBMITTED BY

Ray White Rockhampton Casey
stockers@cqoz.com

CREATED ON

2022-11-23

Floors

1

▼ Ground Floor

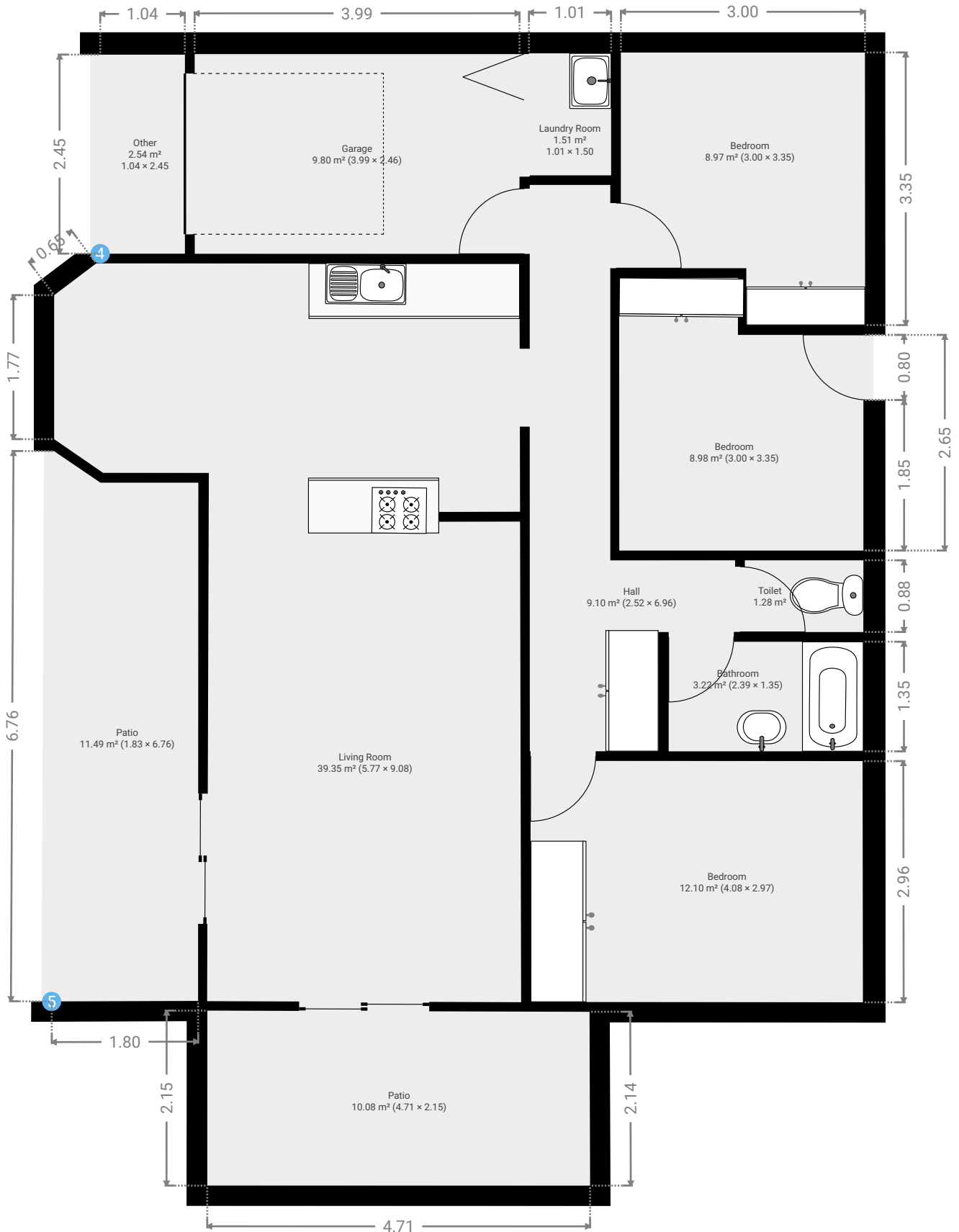

FLOORS: 1

▼ **Bathroom**
Ground Floor

WIDTH: 1.35 m • LENGTH: 2.39 m
AREA: 3.22 m² • PERIMETER: 7.48 m

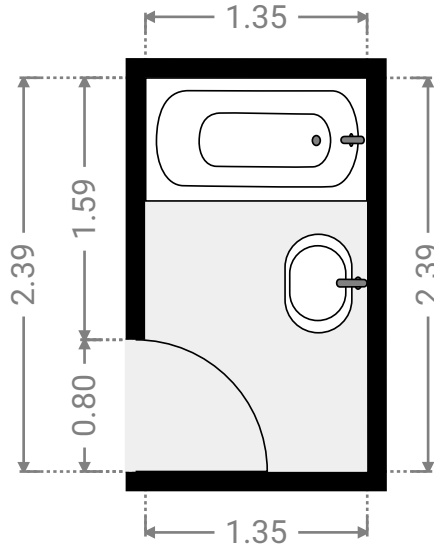
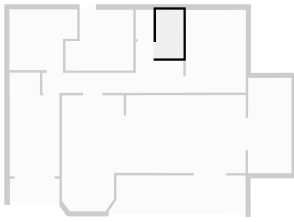

▼ **Bedroom**
Ground Floor

WIDTH: 3.35 m • LENGTH: 3.00 m
AREA: 8.97 m² • PERIMETER: 12.70 m

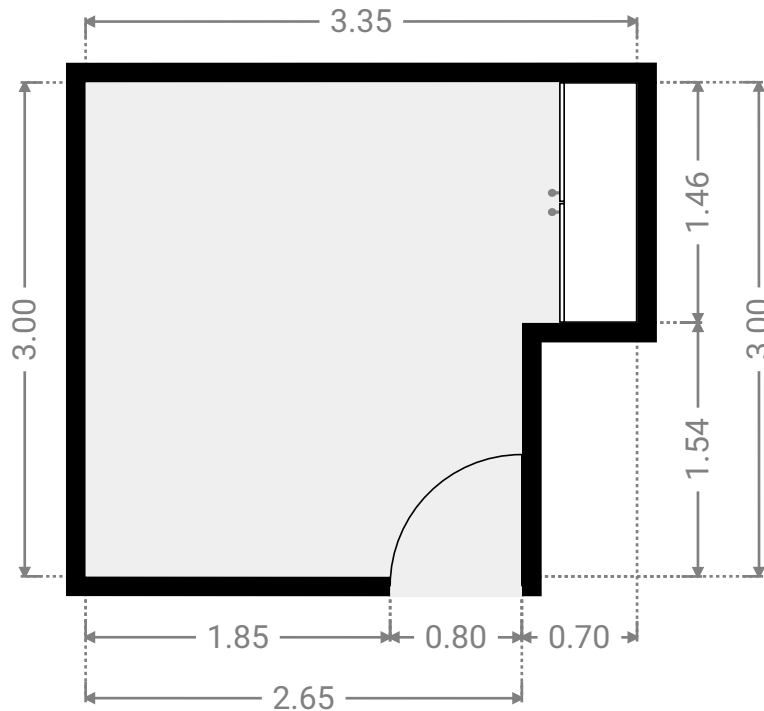
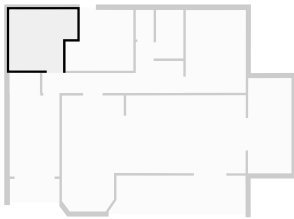

FLOORS: 1

▼ **Bedroom**
Ground Floor

WIDTH: 3.35 m • LENGTH: 3.00 m
AREA: 8.98 m² • PERIMETER: 12.70 m

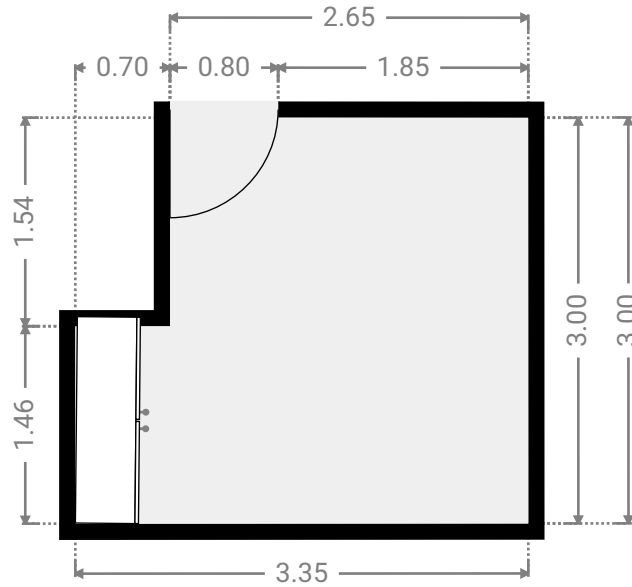
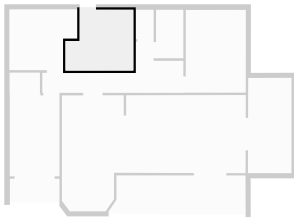

▼ **Bedroom**
Ground Floor

WIDTH: 2.97 m • LENGTH: 4.08 m
AREA: 12.10 m² • PERIMETER: 14.09 m

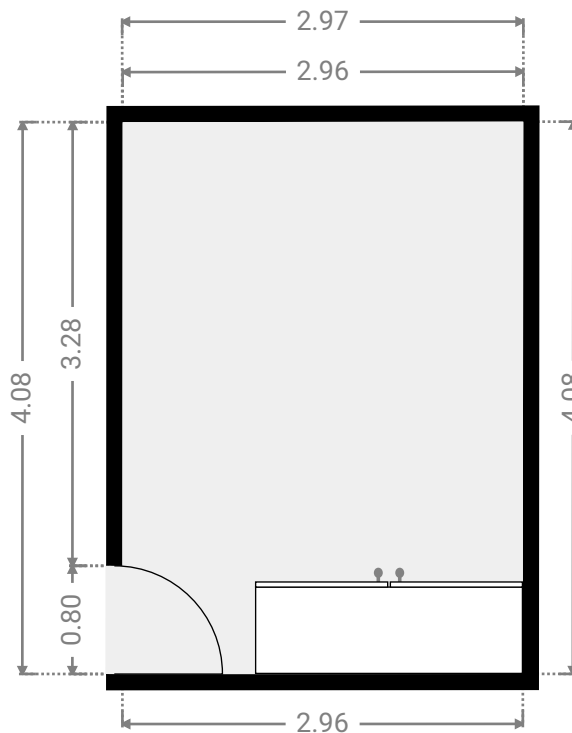
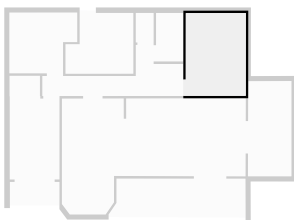

FLOORS: 1

▼ **Garage**
Ground Floor

WIDTH: 2.46 m • LENGTH: 3.99 m
AREA: 9.80 m² • PERIMETER: 12.90 m

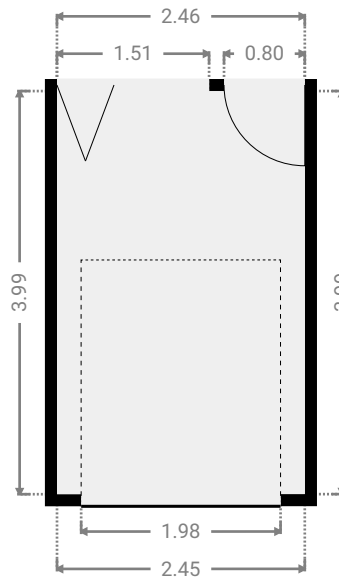
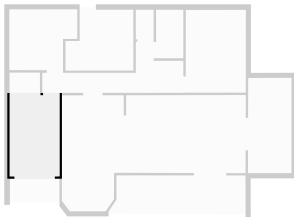

▼ **Hall**
Ground Floor

WIDTH: 6.96 m • LENGTH: 2.52 m
AREA: 9.10 m² • PERIMETER: 18.97 m

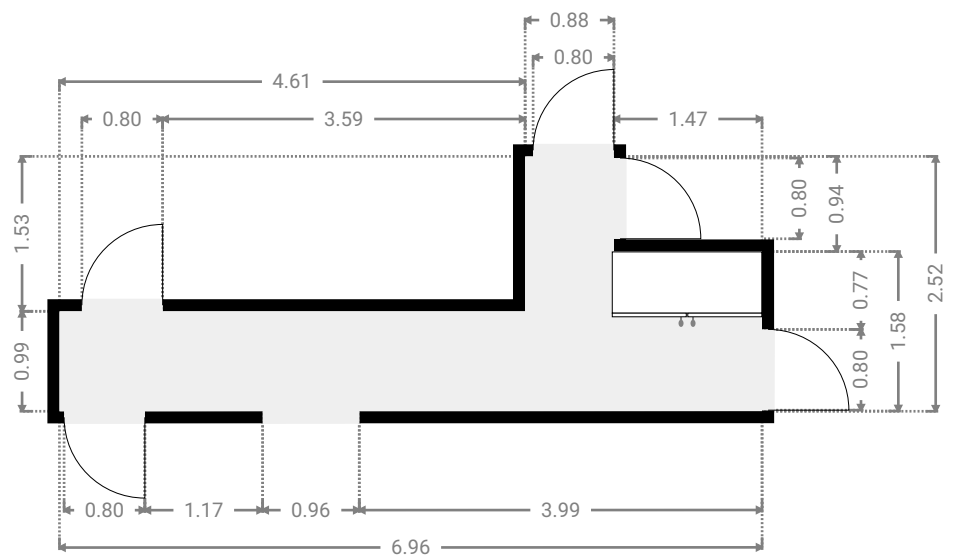
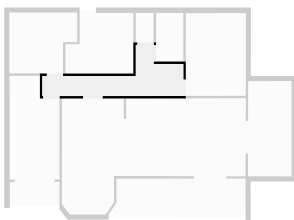

FLOORS: 1

▼ **Laundry Room**
Ground Floor

WIDTH: 1.50 m • LENGTH: 1.01 m
AREA: 1.51 m² • PERIMETER: 5.02 m

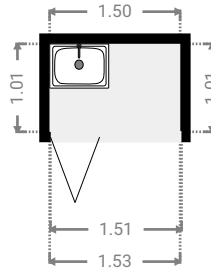
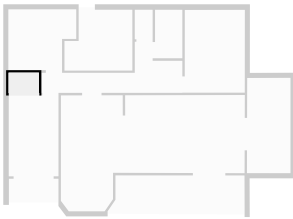

▼ **Living Room**
Ground Floor

WIDTH: 9.08 m • LENGTH: 5.77 m
AREA: 39.35 m² • PERIMETER: 31.08 m

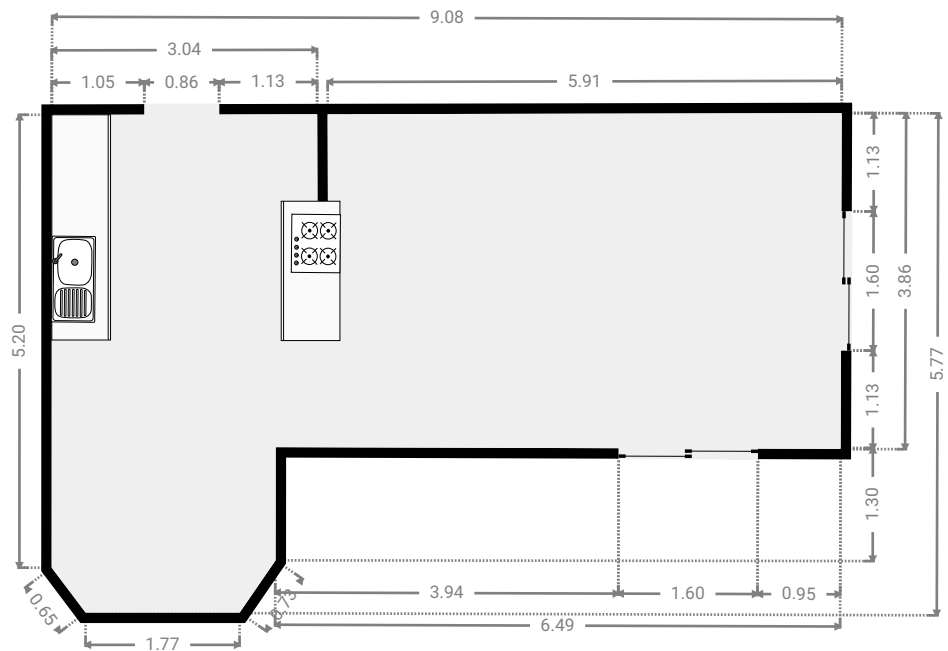
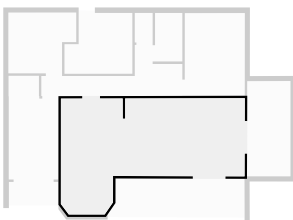

FLOORS: 1

▼ **Other**
Ground Floor

WIDTH: 2.45 m • LENGTH: 1.04 m
AREA: 2.54 m² • PERIMETER: 6.97 m

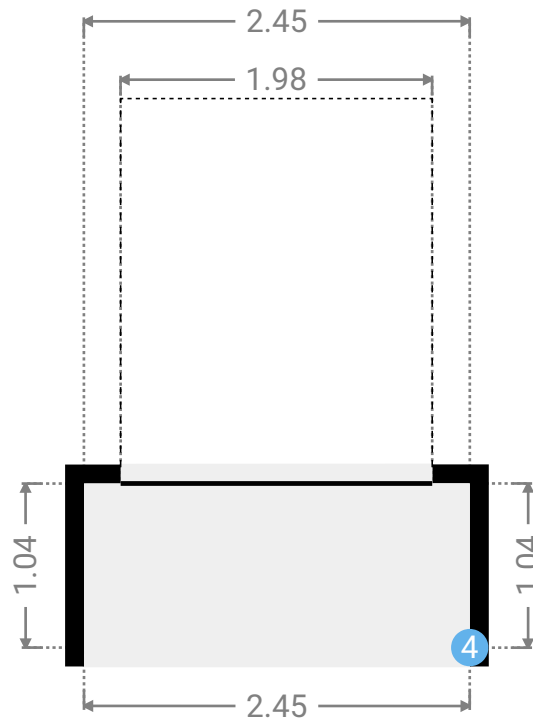
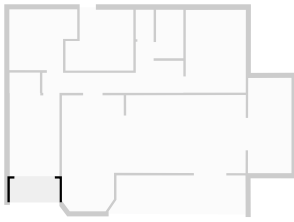

▼ **Other/**Ground Floor

4 OPENING

Height
0.00 m



FLOORS: 1

▼ **Patio**
Ground Floor

WIDTH: 2.15 m • LENGTH: 4.71 m
AREA: 10.08 m² • PERIMETER: 13.69 m

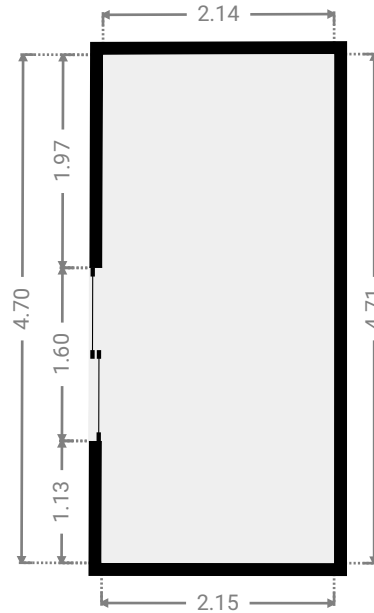
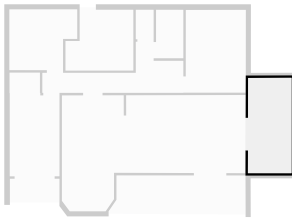

▼ **Patio**
Ground Floor

WIDTH: 6.76 m • LENGTH: 1.83 m
AREA: 11.49 m² • PERIMETER: 16.82 m

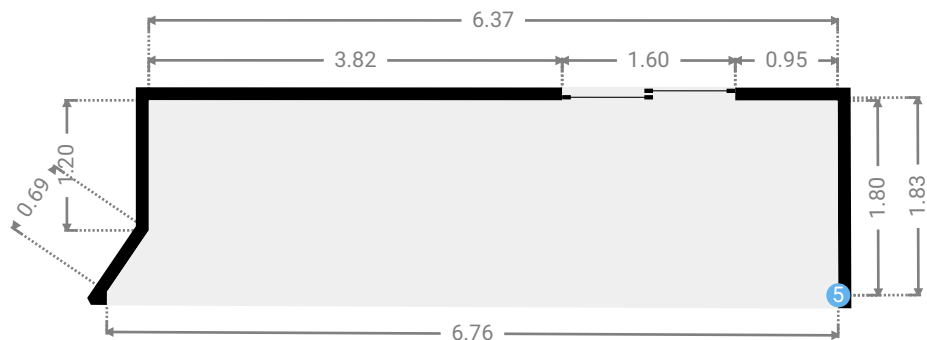
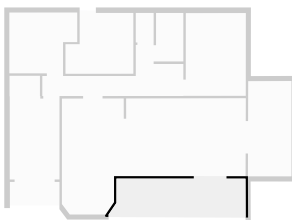

▼ **Patio/**Ground Floor

5 **OPENING**

Height
0.00 m



▼ Toilet
Ground Floor

WIDTH: 0.88 m • LENGTH: 1.46 m
AREA: 1.28 m² • PERIMETER: 4.68 m

