

2/73 Livingstone Street

Created on
2020-09-15

Floors
2

▼ Ground Floor

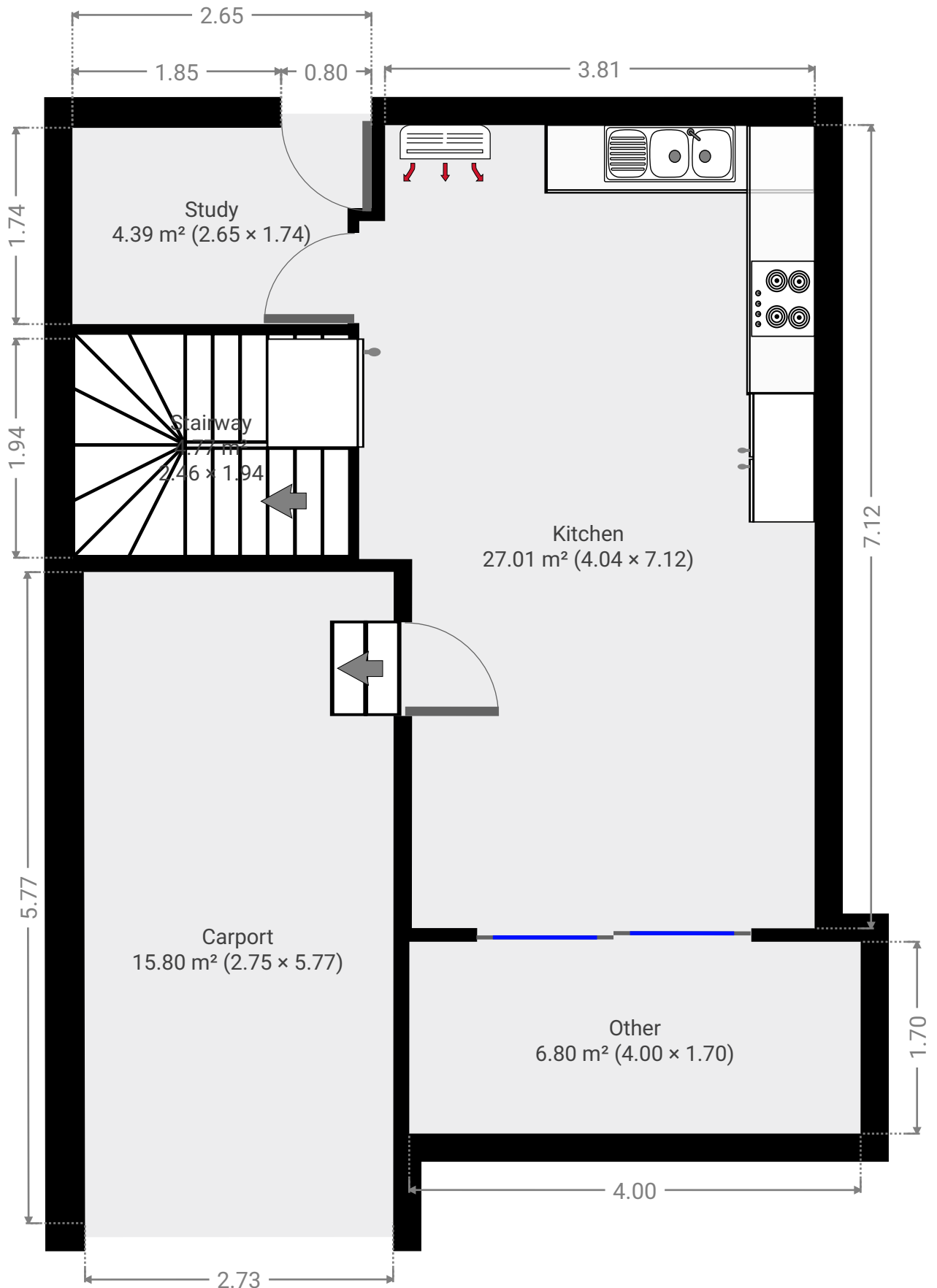

▼ **Kitchen**
Ground Floor

WIDTH: 4.04 m • LENGTH: 7.12 m
AREA: 27.01 m² • PERIMETER: 22.31 m

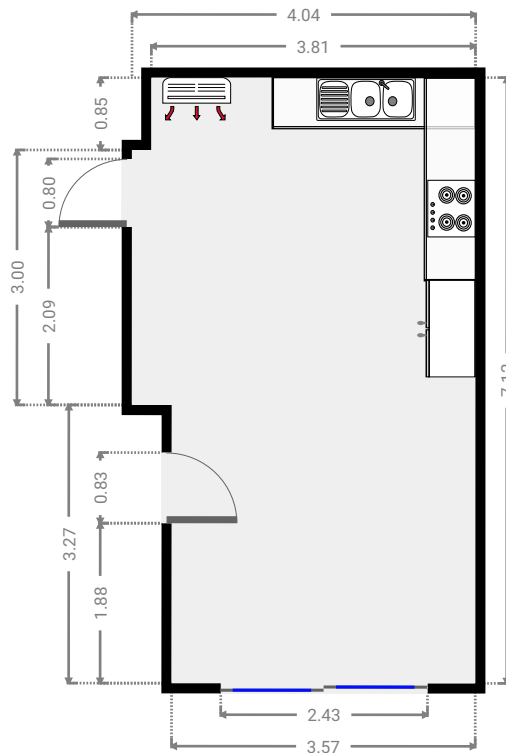
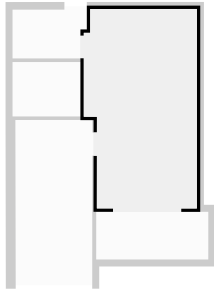

▼ **Study**
Ground Floor

WIDTH: 2.65 m • LENGTH: 1.74 m
AREA: 4.39 m² • PERIMETER: 8.78 m

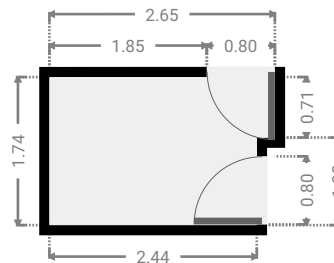
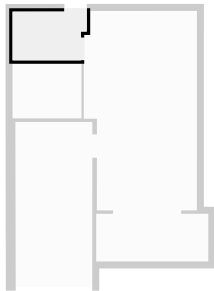

▼ **Stairway**
Ground Floor

WIDTH: 2.46 m • LENGTH: 1.94 m
AREA: 4.77 m² • PERIMETER: 8.80 m

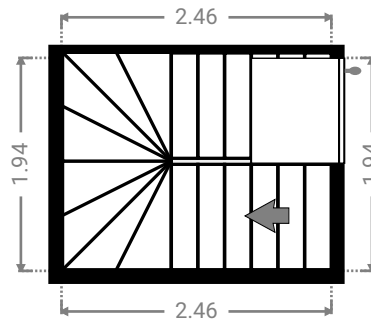
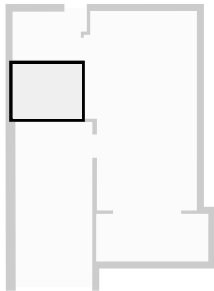

▼ **Carport**
Ground Floor

WIDTH: 2.75 m • LENGTH: 5.77 m
AREA: 15.80 m² • PERIMETER: 17.02 m

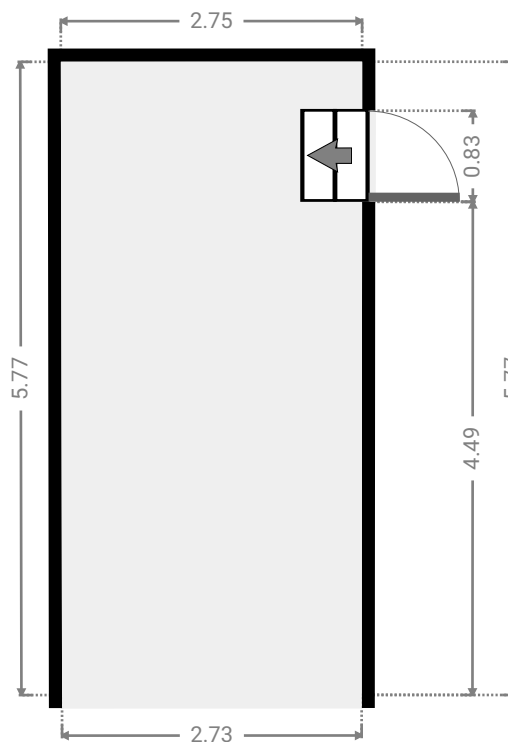
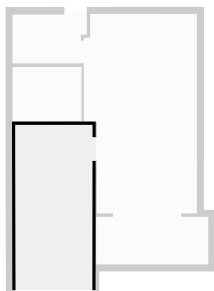

▼ Other
Ground Floor

WIDTH: 4.00 m • LENGTH: 1.70 m
AREA: 6.80 m² • PERIMETER: 11.40 m

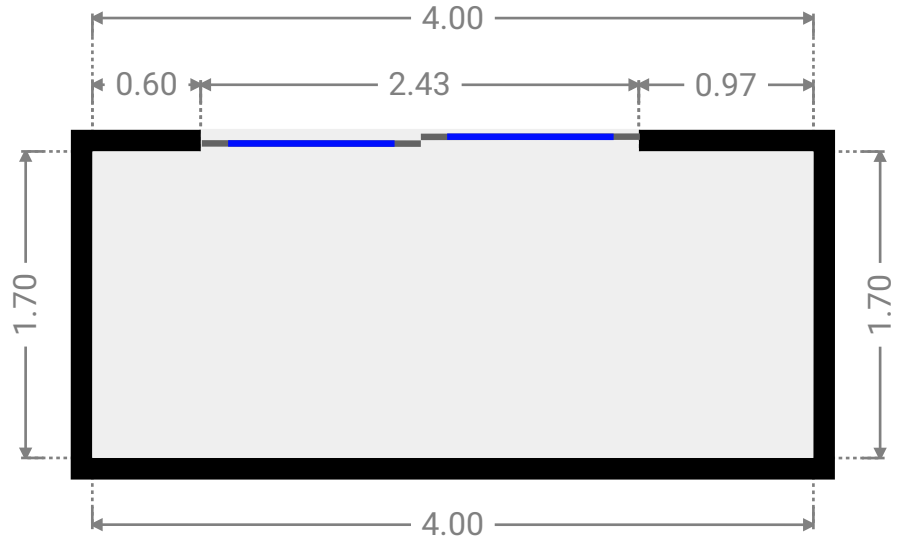
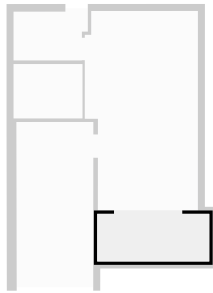

▼ 1st Floor

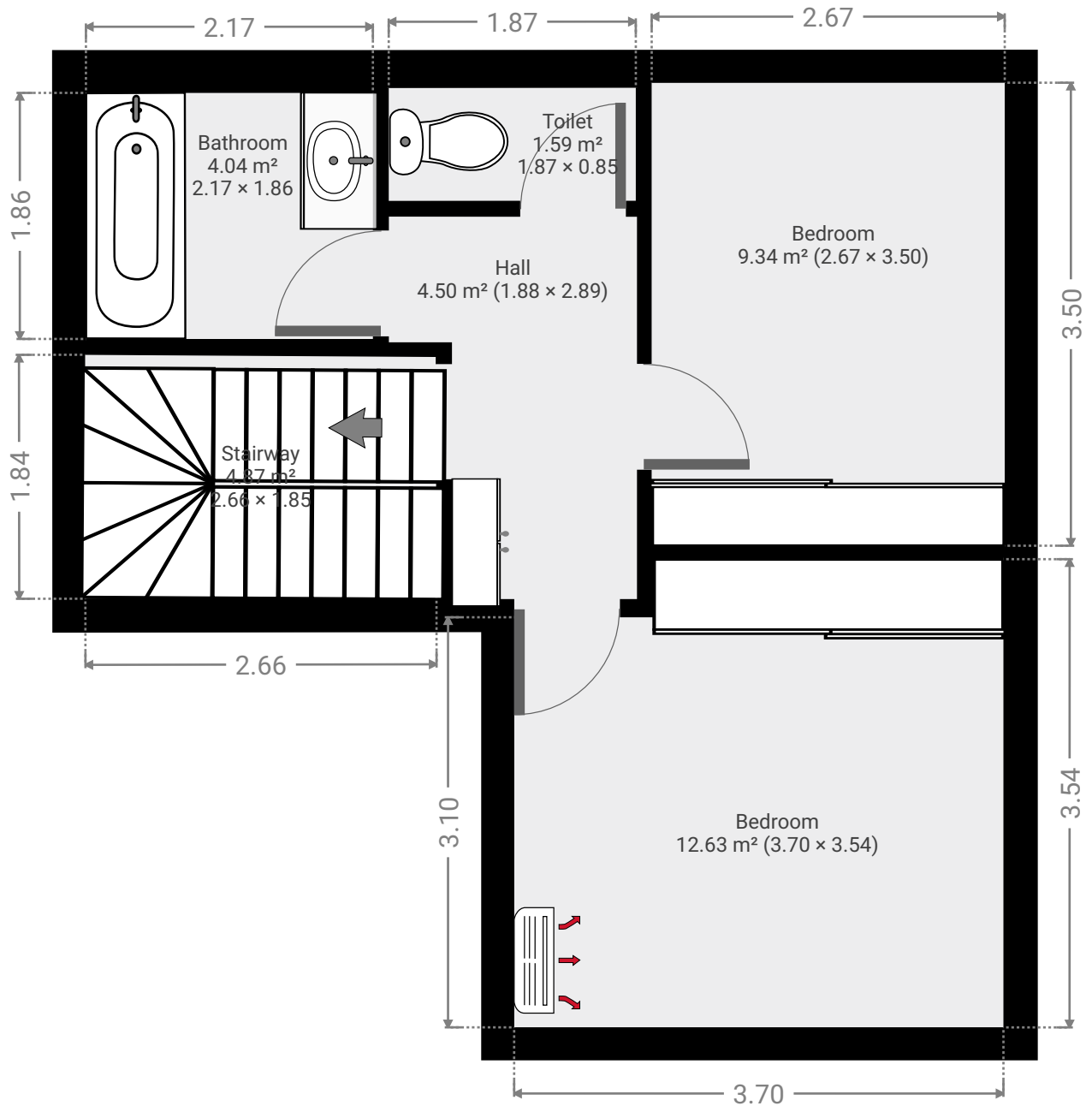

▼ **Hall**
1st Floor

WIDTH: 1.88 m • LENGTH: 2.89 m
AREA: 4.50 m² • PERIMETER: 9.54 m

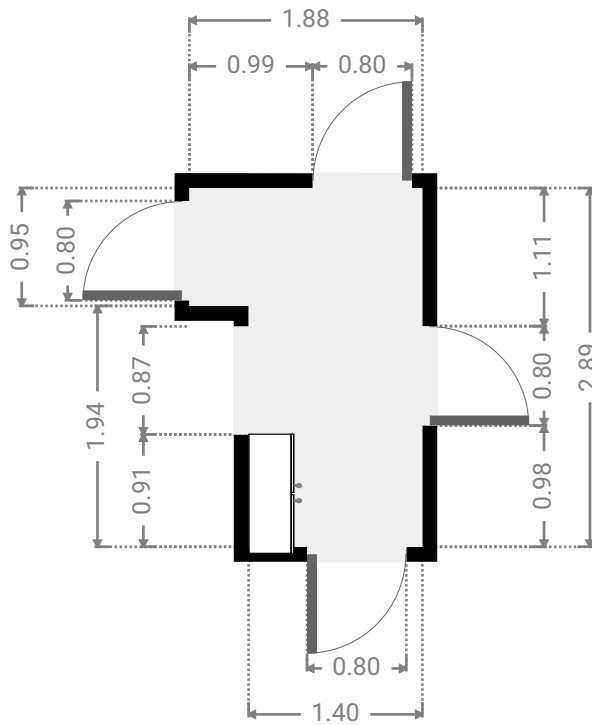
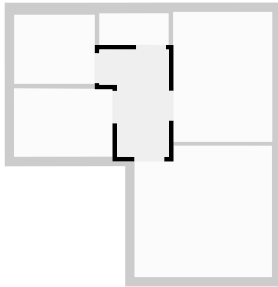

▼ **Bedroom**
1st Floor

WIDTH: 3.70 m • LENGTH: 3.54 m
AREA: 12.63 m² • PERIMETER: 14.48 m

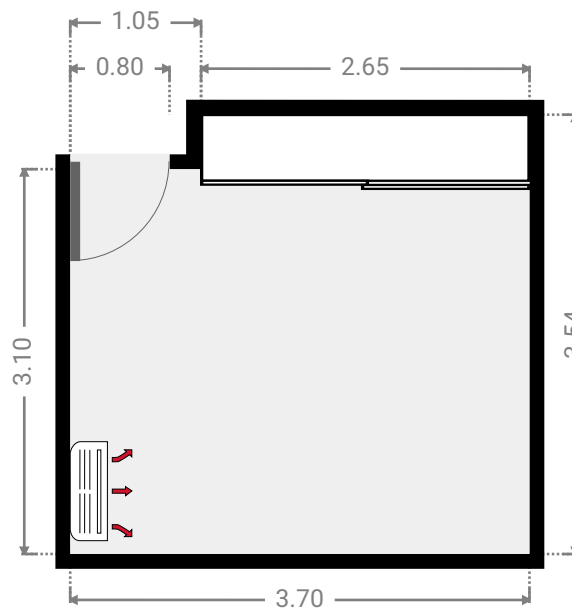
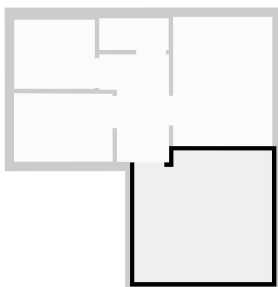

▼ **Bedroom**
1st Floor

WIDTH: 2.67 m • LENGTH: 3.50 m
AREA: 9.34 m² • PERIMETER: 12.34 m

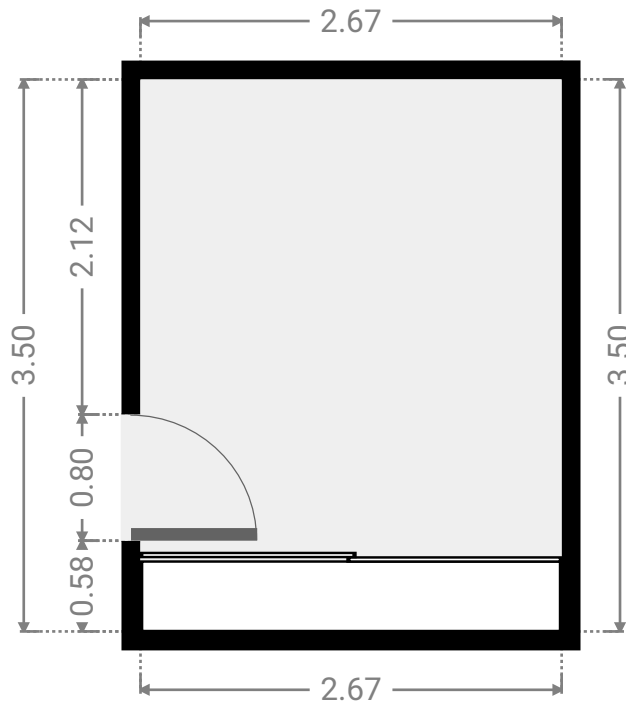
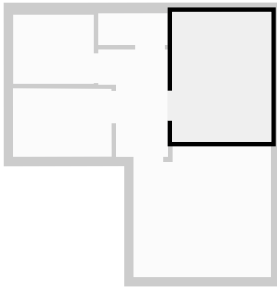

▼ **Toilet**
1st Floor

WIDTH: 1.87 m • LENGTH: 0.85 m
AREA: 1.59 m² • PERIMETER: 5.44 m

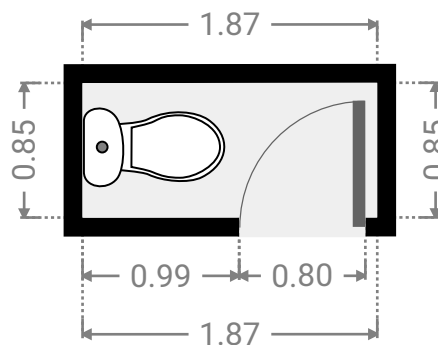
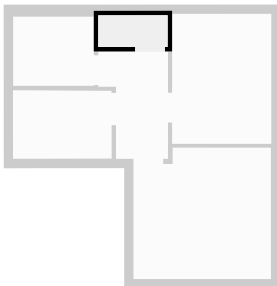

▼ Bathroom
1st Floor

WIDTH: 2.17 m • LENGTH: 1.86 m
AREA: 4.04 m² • PERIMETER: 8.06 m

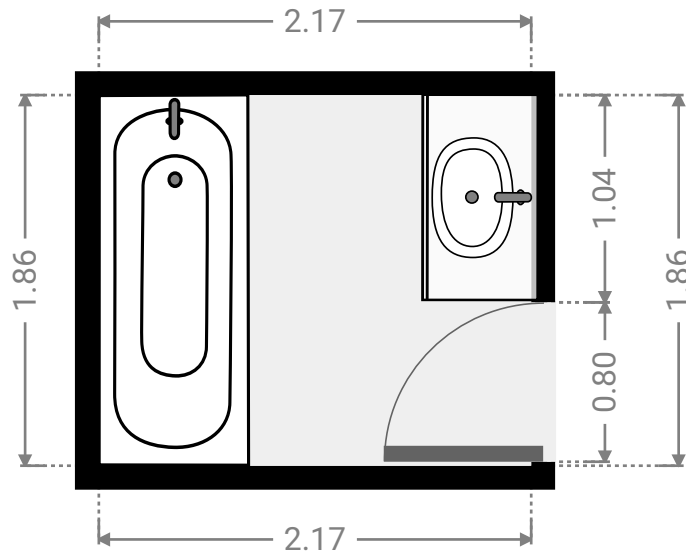
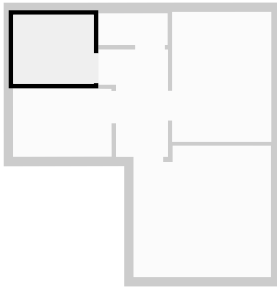

▼ Stairway
1st Floor

WIDTH: 2.66 m • LENGTH: 1.85 m
AREA: 4.87 m² • PERIMETER: 8.97 m

