

2/45 Denning Street

Created on
2021-05-13

Floors
1

▼ Ground Floor



▼ Kitchen
Ground Floor

WIDTH: 7.17 m • LENGTH: 6.00 m
AREA: 31.41 m² • PERIMETER: 26.34 m

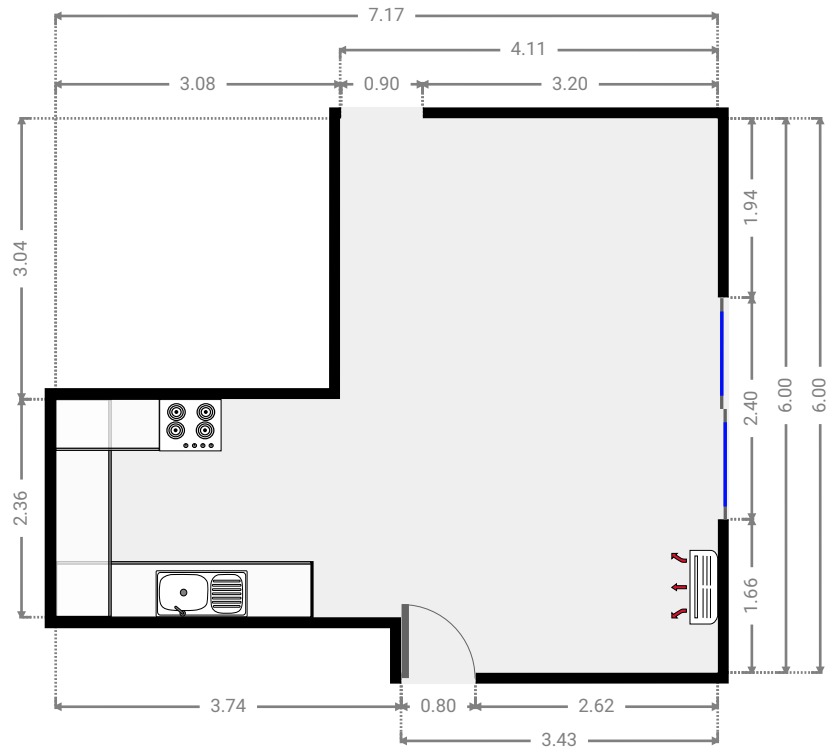
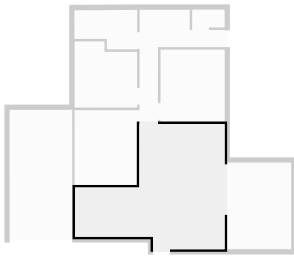

▼ Hall
Ground Floor

WIDTH: 4.08 m • LENGTH: 5.35 m
AREA: 8.81 m² • PERIMETER: 18.86 m

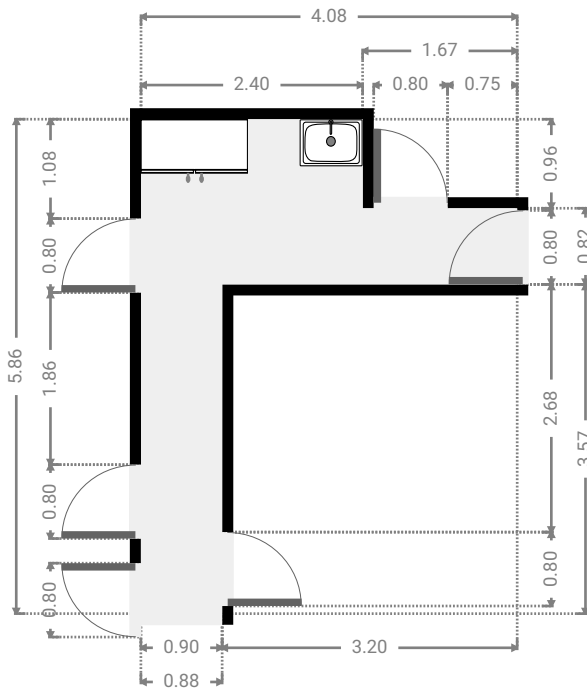
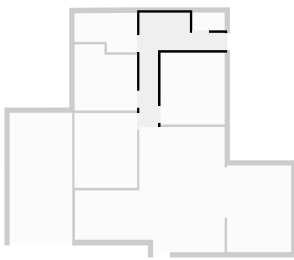

▼ **Master Bedroom**
Ground Floor

WIDTH: 3.00 m • LENGTH: 3.58 m
AREA: 10.74 m² • PERIMETER: 13.16 m

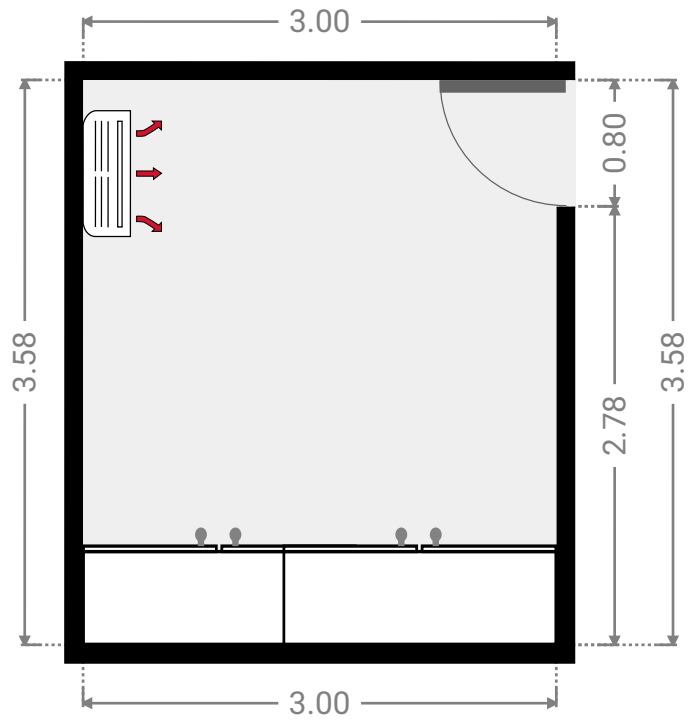
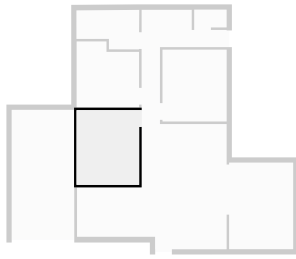

▼ **Bedroom**
Ground Floor

WIDTH: 3.08 m • LENGTH: 3.44 m
AREA: 10.58 m² • PERIMETER: 13.03 m

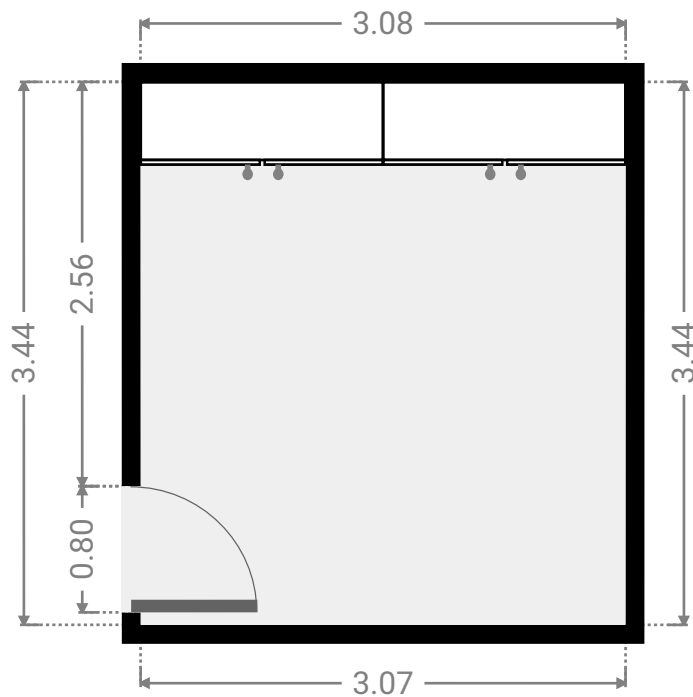
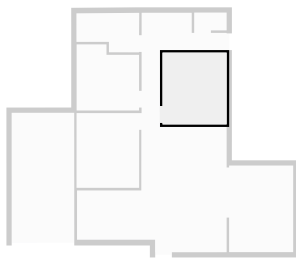

▼ **Bedroom**
Ground Floor

WIDTH: 2.99 m • LENGTH: 3.17 m
AREA: 8.69 m² • PERIMETER: 12.32 m

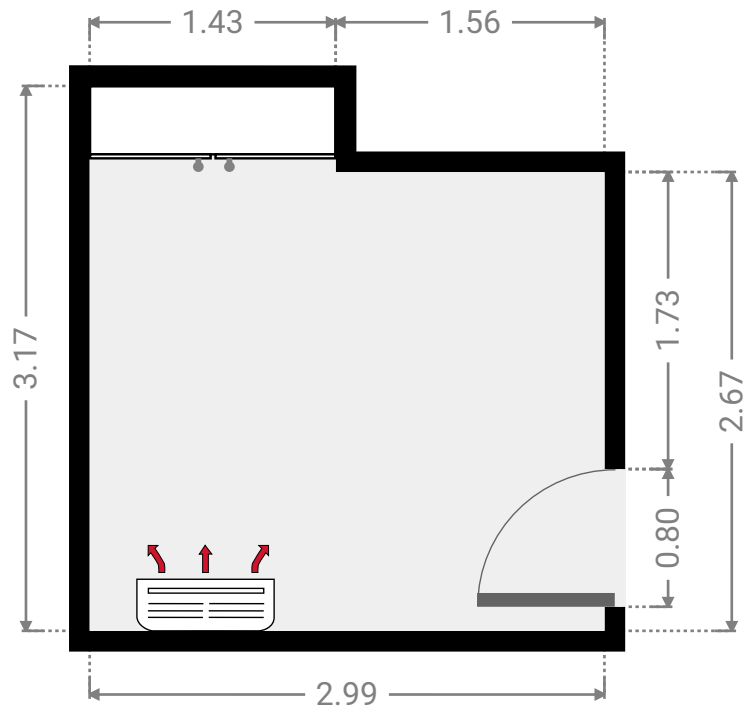
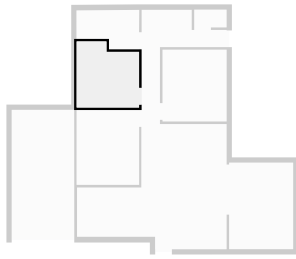

▼ **Bathroom**
Ground Floor

WIDTH: 3.01 m • LENGTH: 1.89 m
AREA: 4.86 m² • PERIMETER: 9.76 m

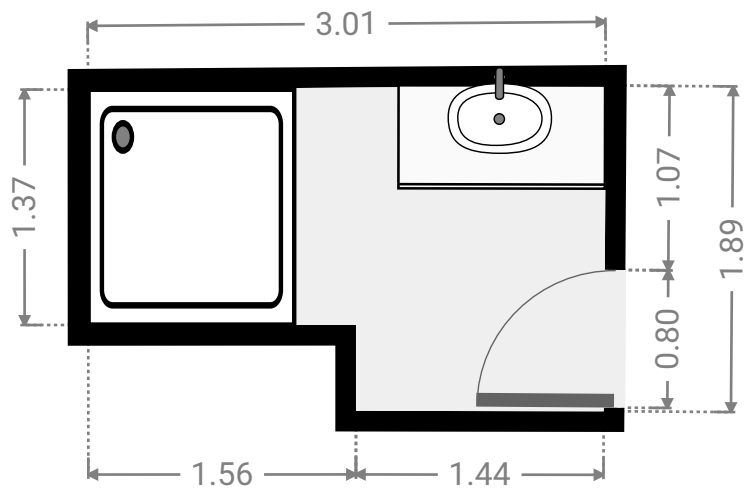
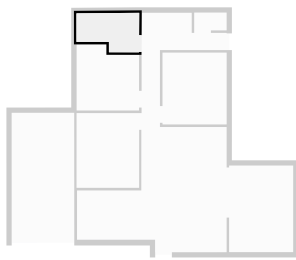

▼ **Toilet**
Ground Floor

WIDTH: 1.55 m • LENGTH: 0.85 m
AREA: 1.33 m² • PERIMETER: 4.82 m

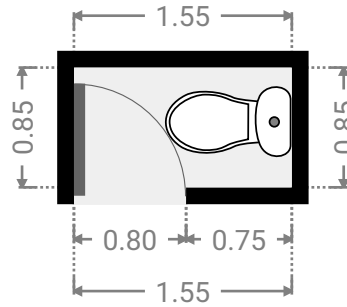
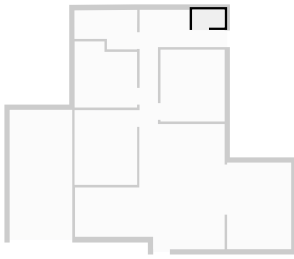

▼ **Other**
Ground Floor

WIDTH: 3.07 m • LENGTH: 4.15 m
AREA: 12.74 m² • PERIMETER: 14.44 m

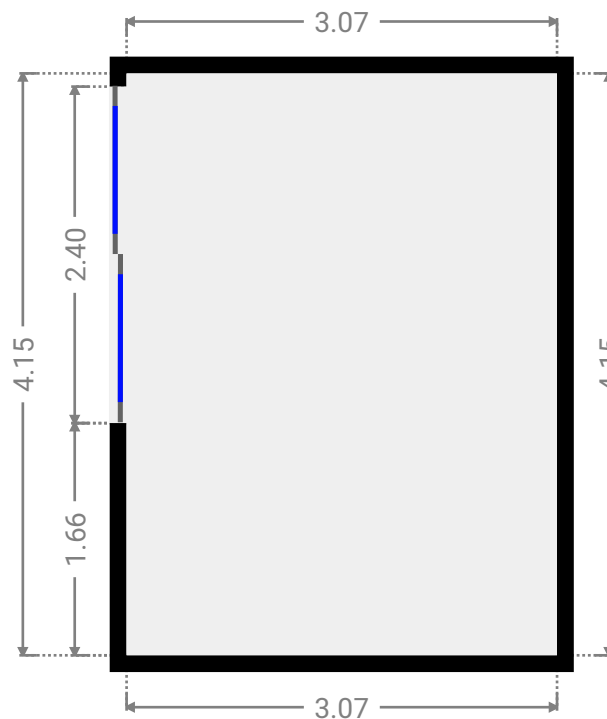
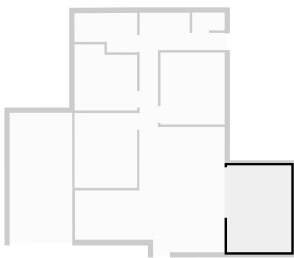

▼ **Garage**
Ground Floor

WIDTH: 3.00 m • LENGTH: 6.11 m
AREA: 18.32 m² • PERIMETER: 18.22 m

