

2/382 Richardson road

SUBMITTED BY

Ray White Rockhampton Casey
stockers@cqoz.com

CREATED ON

2022-05-16

Floors

1

▼ Ground Floor

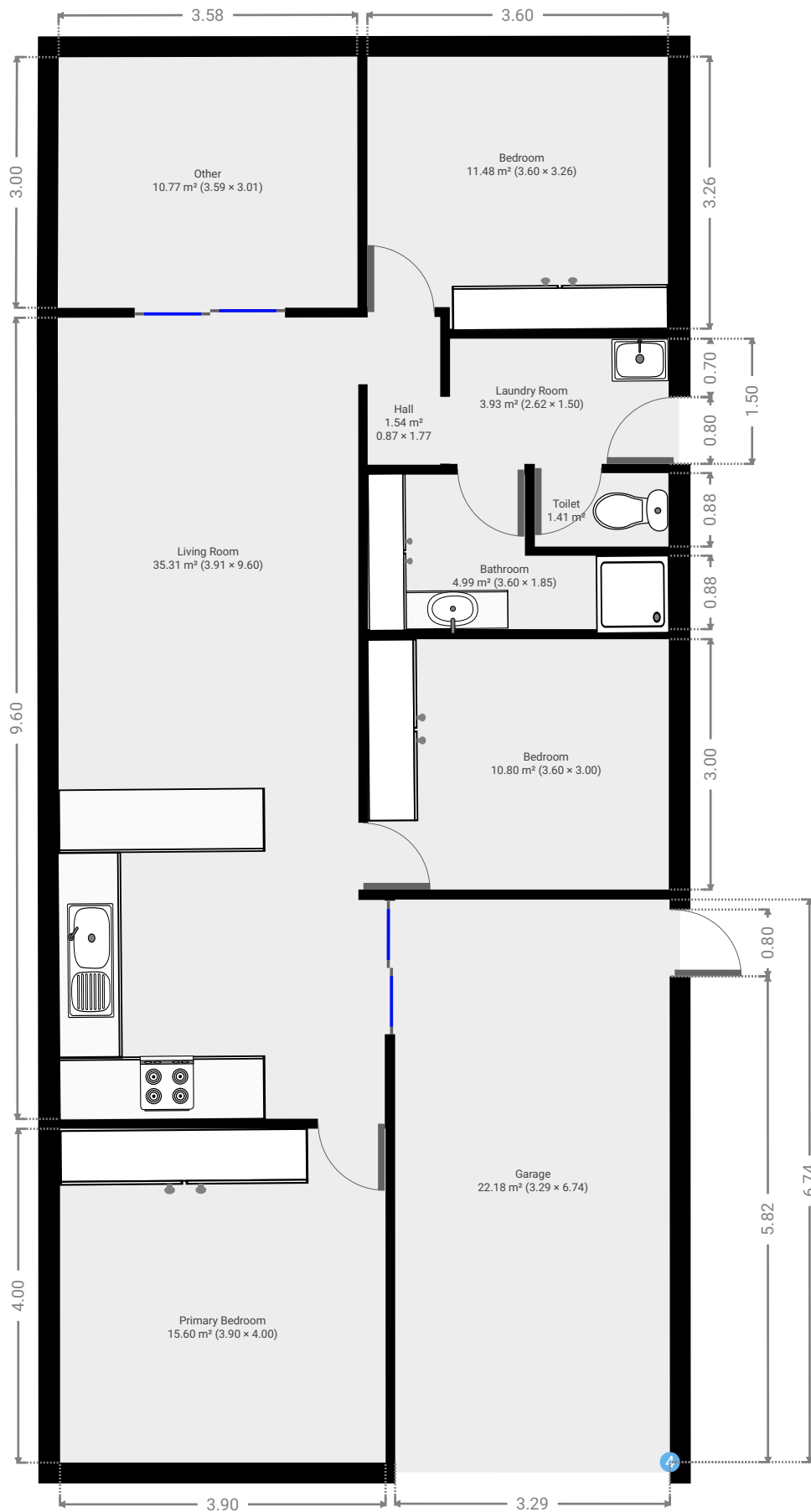

FLOORS: 1

▼ **Bathroom**
Ground Floor

WIDTH: 3.60 m • LENGTH: 1.85 m
AREA: 4.99 m² • PERIMETER: 10.91 m

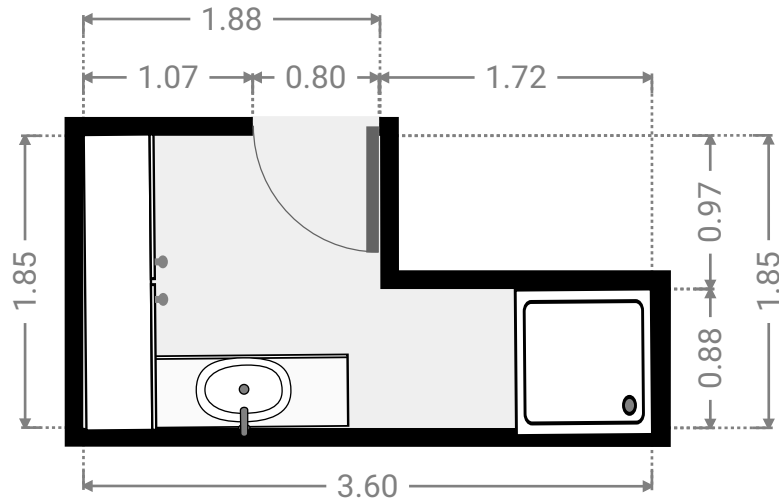
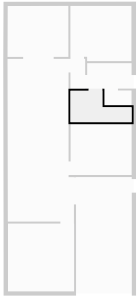

▼ **Bedroom**
Ground Floor

WIDTH: 3.60 m • LENGTH: 3.26 m
AREA: 11.48 m² • PERIMETER: 13.72 m

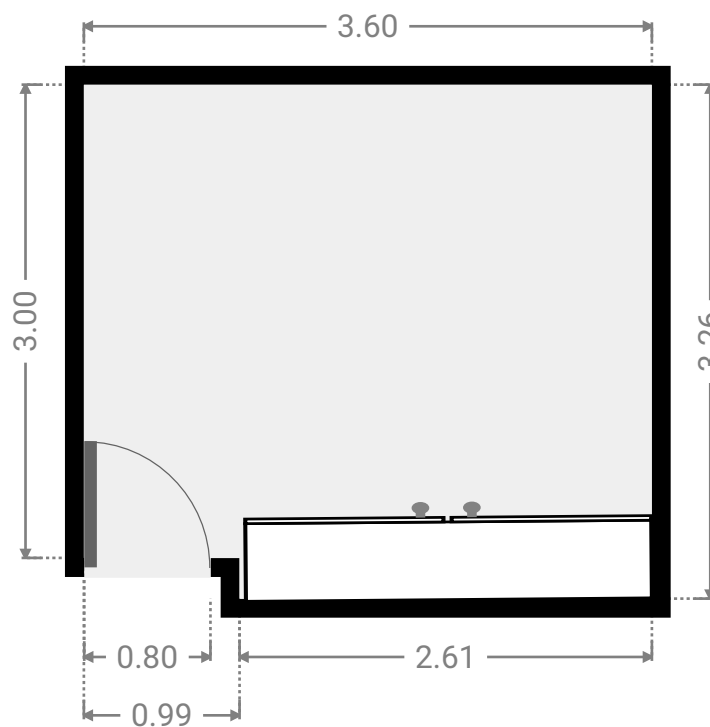
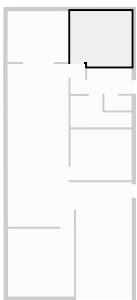

FLOORS: 1

▼ **Bedroom**
Ground Floor

WIDTH: 3.60 m • LENGTH: 3.00 m
AREA: 10.80 m² • PERIMETER: 13.20 m

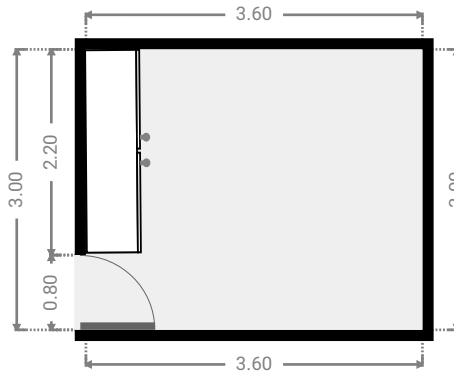
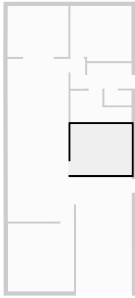

▼ **Garage**
Ground Floor

WIDTH: 3.29 m • LENGTH: 6.74 m
AREA: 22.18 m² • PERIMETER: 20.06 m

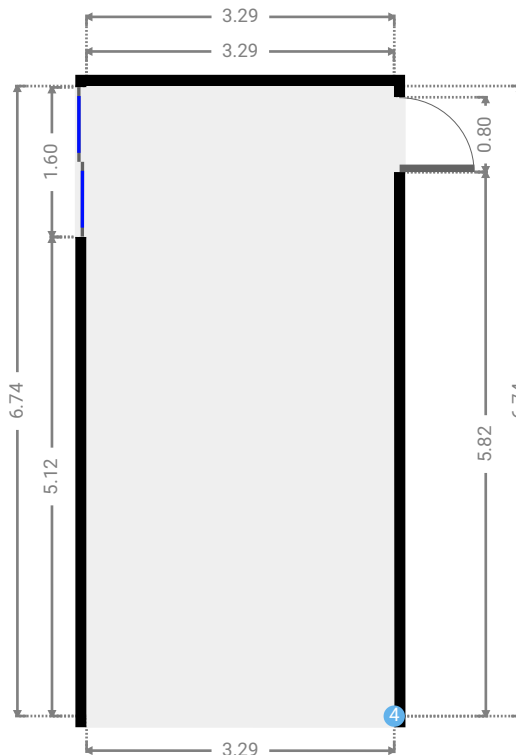
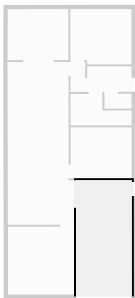

▼ **Garage**/Ground Floor

4 **OPENING**

Height
0.00 m



FLOORS: 1

▼ Hall
Ground Floor

WIDTH: 0.87 m • LENGTH: 1.77 m
AREA: 1.54 m² • PERIMETER: 5.28 m

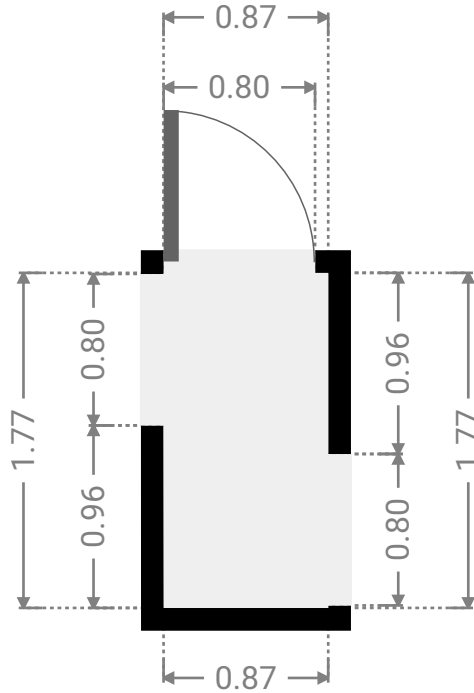
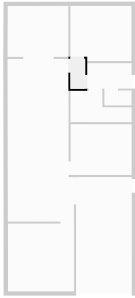

▼ Laundry Room
Ground Floor

WIDTH: 2.62 m • LENGTH: 1.50 m
AREA: 3.93 m² • PERIMETER: 8.24 m

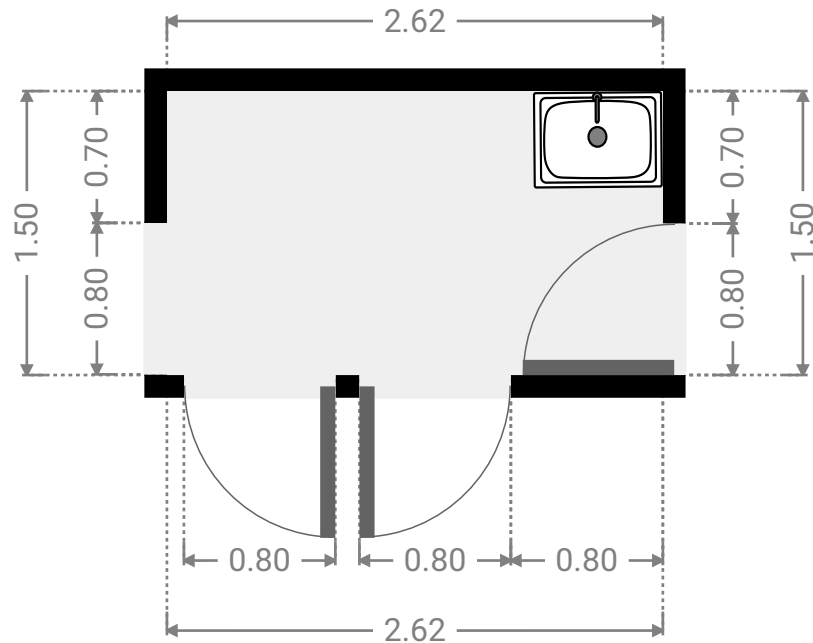
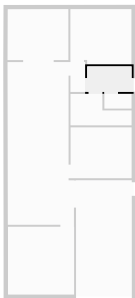

FLOORS: 1

▼ **Living Room**
Ground Floor

WIDTH: 3.91 m • LENGTH: 9.60 m
AREA: 35.31 m² • PERIMETER: 27.02 m

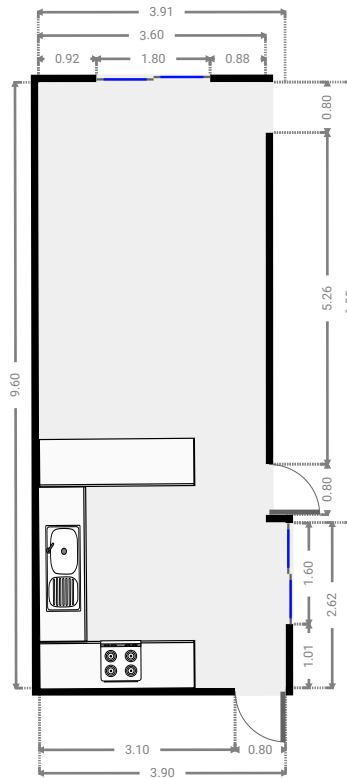
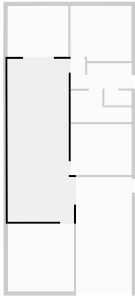

▼ **Other**
Ground Floor

WIDTH: 3.59 m • LENGTH: 3.01 m
AREA: 10.77 m² • PERIMETER: 13.18 m

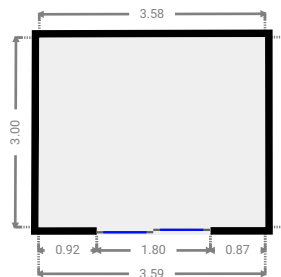
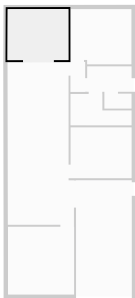

FLOORS: 1

▼ **Primary Bedroom**
Ground Floor

WIDTH: 3.90 m • LENGTH: 4.00 m
AREA: 15.60 m² • PERIMETER: 15.80 m

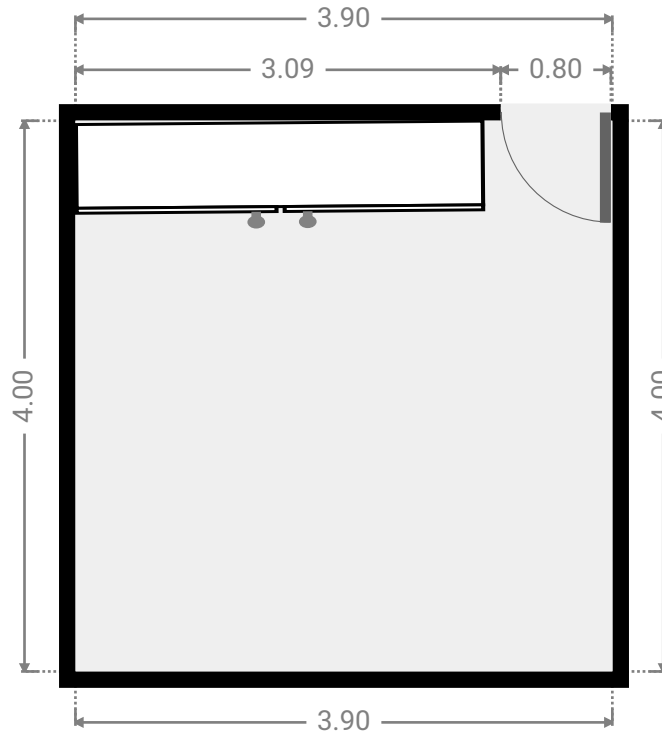
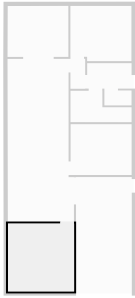

▼ **Toilet**
Ground Floor

WIDTH: 1.60 m • LENGTH: 0.88 m
AREA: 1.41 m² • PERIMETER: 4.96 m

