

# 2/181 Lucas street

**SUBMITTED BY**

Ray White Rockhampton Casey  
stockers@cqoz.com

---

**CREATED ON**

2022-03-09

---

**Floors**

1

---

▼ Ground Floor

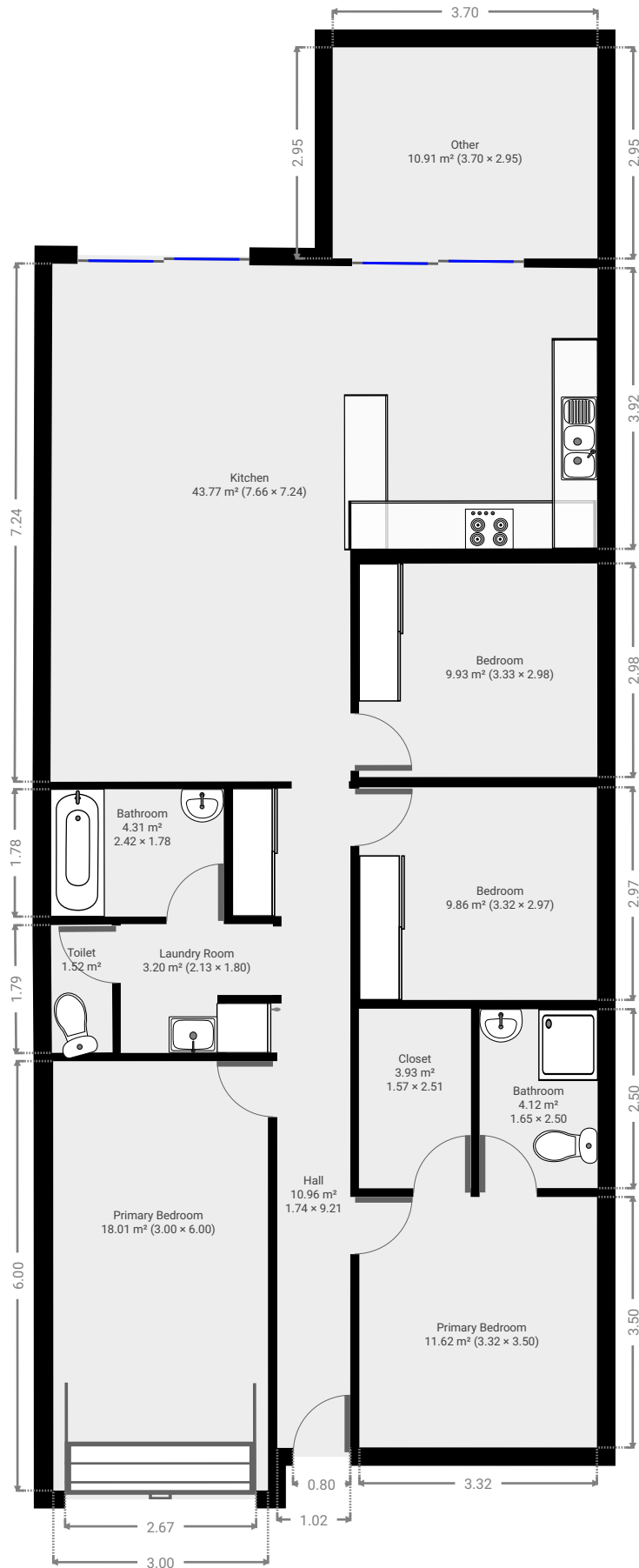

▼ Hall  
Ground Floor

WIDTH: 1.74 m • LENGTH: 9.21 m  
AREA: 10.96 m<sup>2</sup> • PERIMETER: 23.28 m

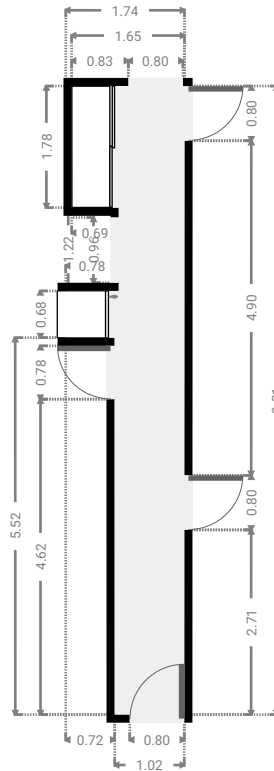
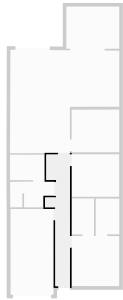

▼ Primary Bedroom  
Ground Floor

WIDTH: 3.32 m • LENGTH: 3.50 m  
AREA: 11.62 m<sup>2</sup> • PERIMETER: 13.64 m

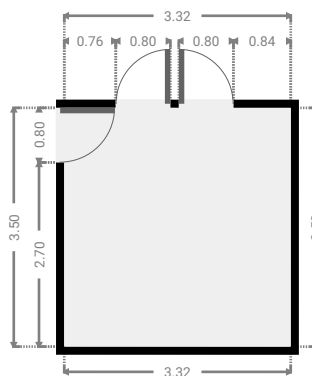
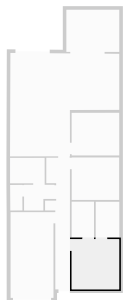

▼ **Bathroom**  
Ground Floor

WIDTH: 1.65 m • LENGTH: 2.50 m  
AREA: 4.12 m<sup>2</sup> • PERIMETER: 8.30 m

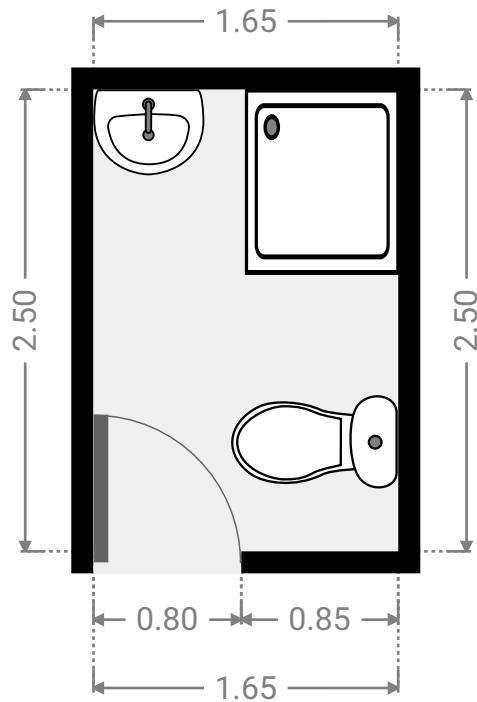
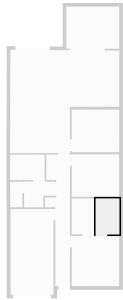

▼ **Closet**  
Ground Floor

WIDTH: 1.57 m • LENGTH: 2.51 m  
AREA: 3.93 m<sup>2</sup> • PERIMETER: 8.15 m

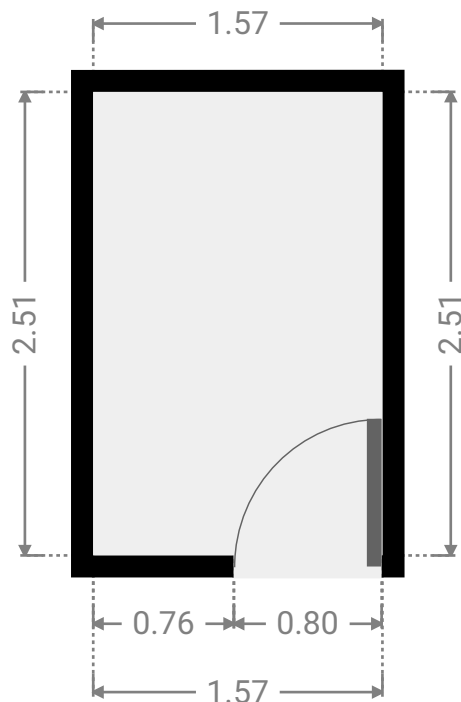
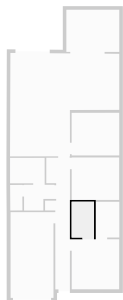

▼ **Primary Bedroom**  
Ground Floor

WIDTH: 3.00 m • LENGTH: 6.00 m  
AREA: 18.01 m<sup>2</sup> • PERIMETER: 18.00 m

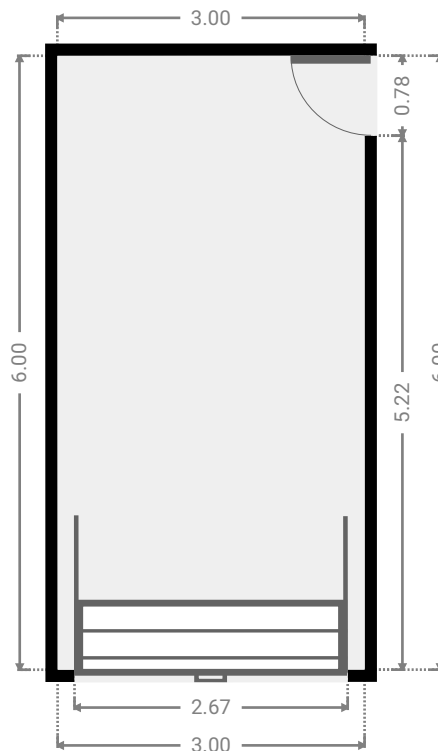
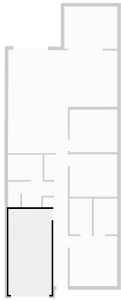

▼ **Laundry Room**  
Ground Floor

WIDTH: 2.13 m • LENGTH: 1.80 m  
AREA: 3.20 m<sup>2</sup> • PERIMETER: 7.85 m

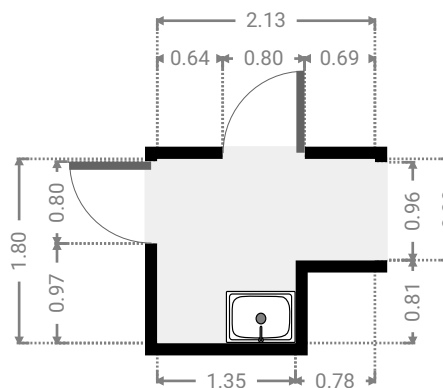
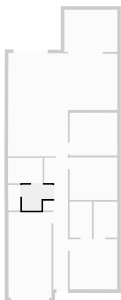

▼ **Toilet**  
Ground Floor

WIDTH: 0.85 m • LENGTH: 1.79 m  
AREA: 1.52 m<sup>2</sup> • PERIMETER: 5.27 m

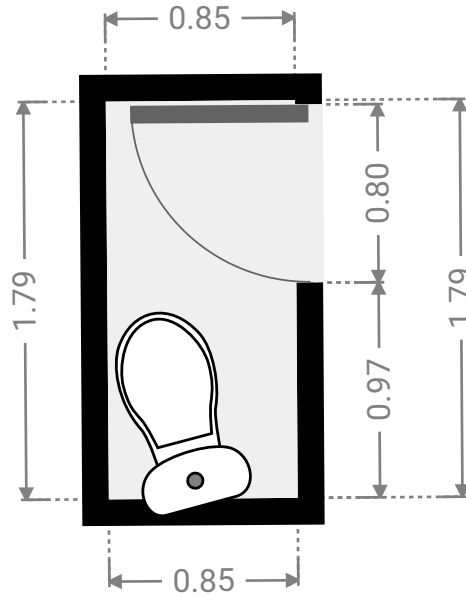
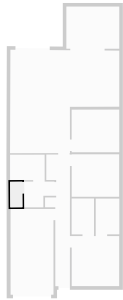

▼ **Bathroom**  
Ground Floor

WIDTH: 2.42 m • LENGTH: 1.78 m  
AREA: 4.31 m<sup>2</sup> • PERIMETER: 8.40 m

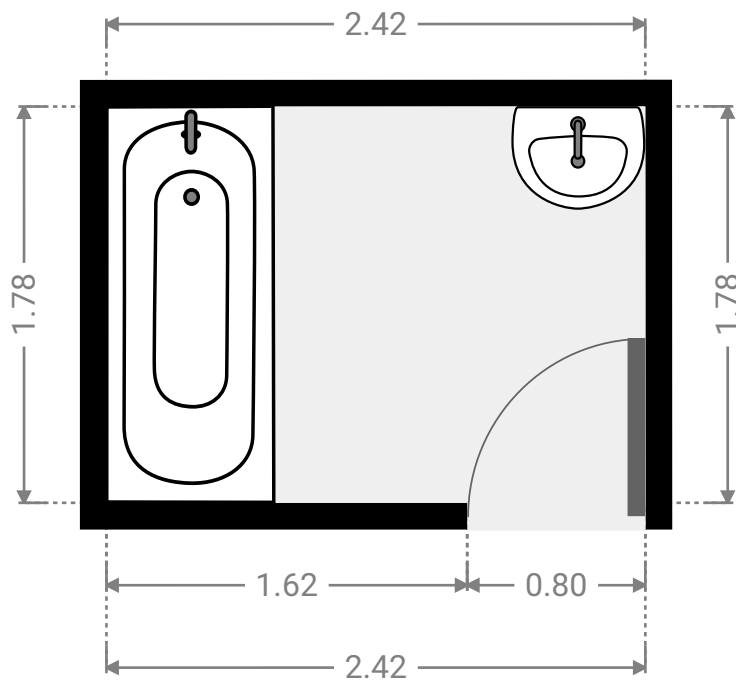
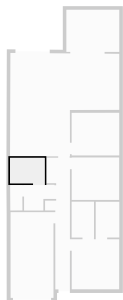

▼ **Bedroom**  
Ground Floor

WIDTH: 3.32 m • LENGTH: 2.97 m  
AREA: 9.86 m<sup>2</sup> • PERIMETER: 12.58 m

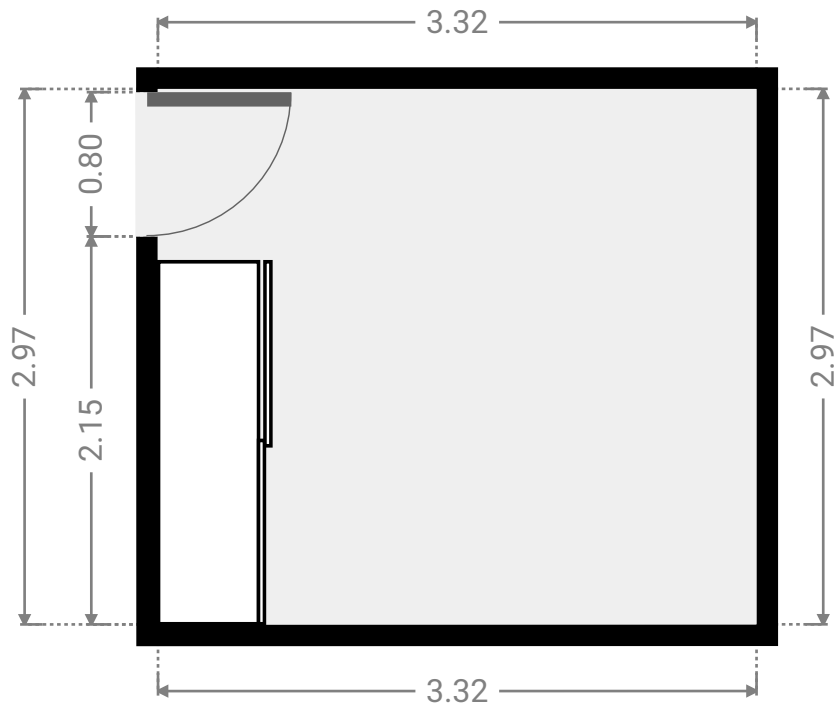
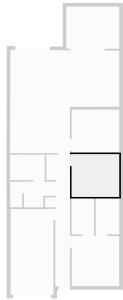

▼ **Bedroom**  
Ground Floor

WIDTH: 3.33 m • LENGTH: 2.98 m  
AREA: 9.93 m<sup>2</sup> • PERIMETER: 12.62 m

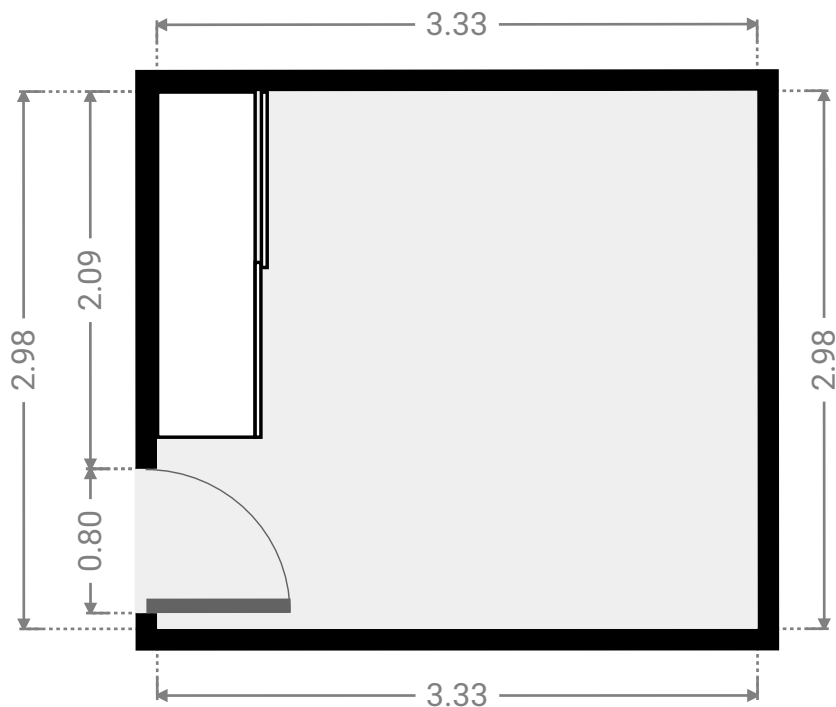
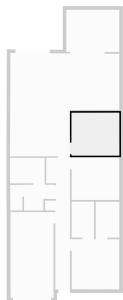

▼ **Kitchen**  
Ground Floor

WIDTH: 7.66 m • LENGTH: 7.24 m  
AREA: 43.77 m<sup>2</sup> • PERIMETER: 29.66 m

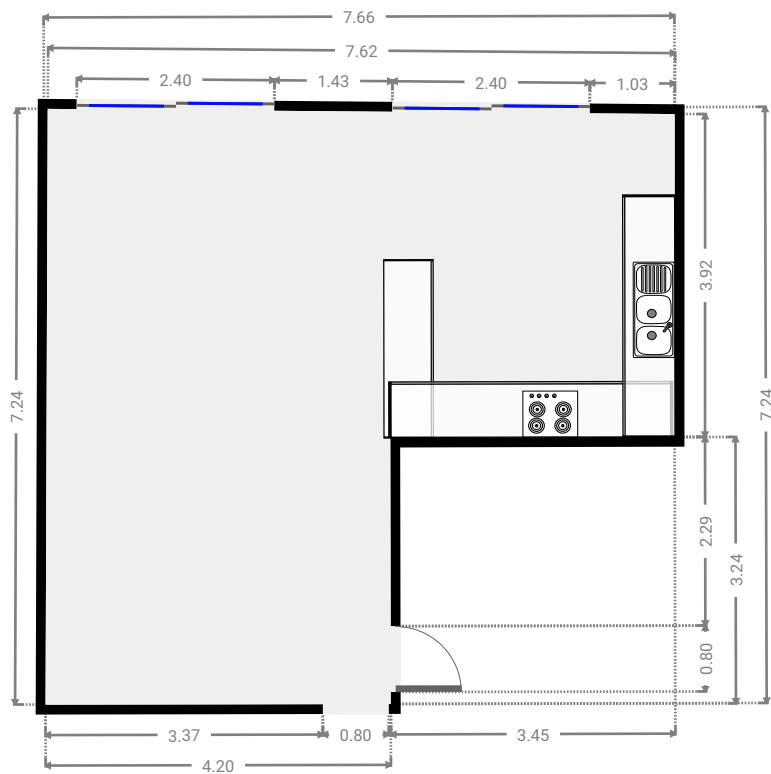
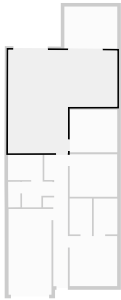

▼ **Other**  
Ground Floor

WIDTH: 3.70 m • LENGTH: 2.95 m  
AREA: 10.91 m<sup>2</sup> • PERIMETER: 13.30 m

