

# 191 Vallis Street

## Ground Floor

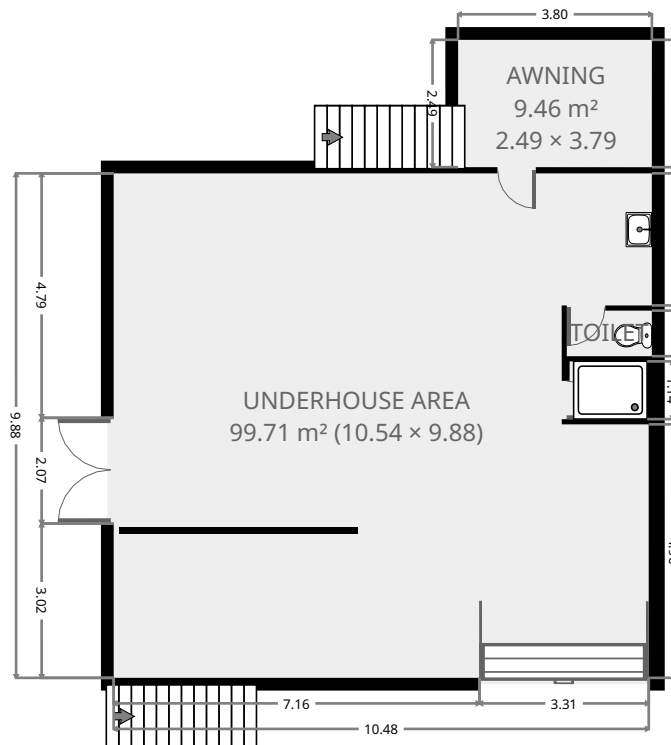

THIS FLOORPLAN IS PROVIDED WITHOUT WARRANTY OF ANY KIND. SENSOPIA DISCLAIMS ANY WARRANTY INCLUDING, WITHOUT LIMITATION, SATISFACTORY QUALITY OR ACCURACY OF DIMENSIONS.

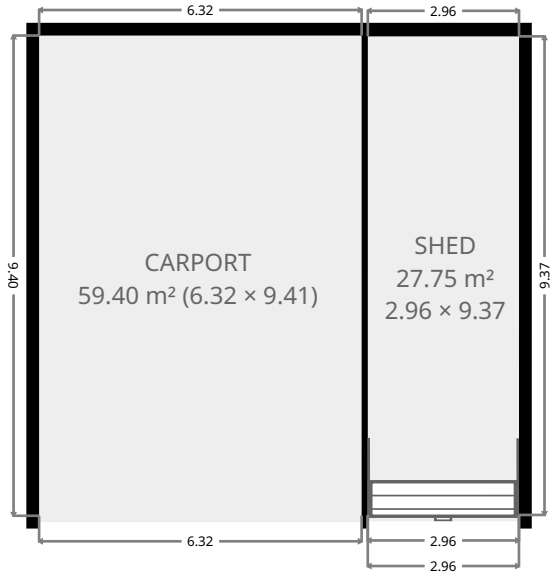

# 191 Vallis Street

## Underhouse Area

Width: 9.88 m  
Length: 10.54 m  
Area: 99.71 m<sup>2</sup>  
Perimeter: 44.25 m

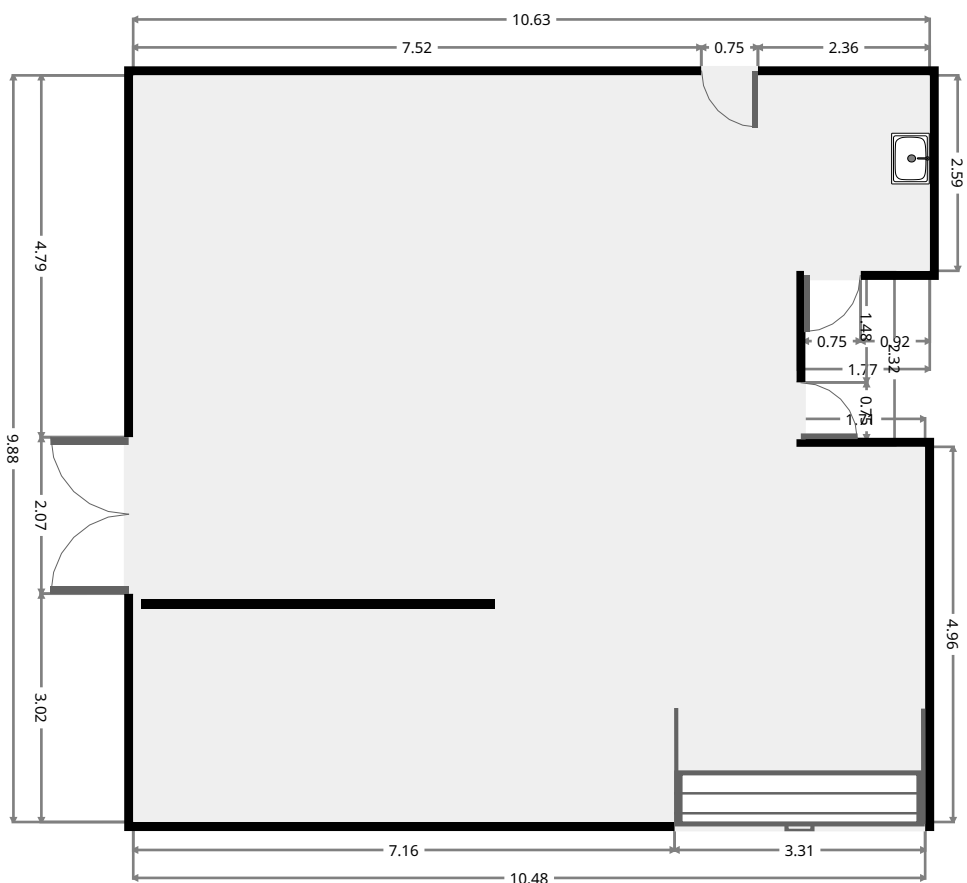
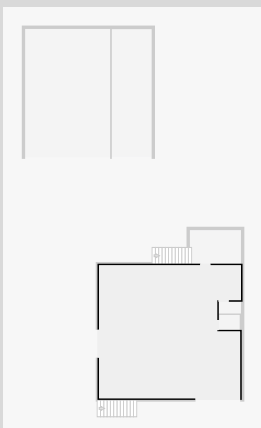

THIS FLOORPLAN IS PROVIDED WITHOUT WARRANTY OF ANY KIND. SENSOPIA DISCLAIMS ANY WARRANTY INCLUDING, WITHOUT LIMITATION, SATISFACTORY QUALITY OR ACCURACY OF DIMENSIONS.



# 191 Vallis Street

## Toilet

Width: 0.89 m  
Length: 1.67 m  
Area: 1.49 m<sup>2</sup>  
Perimeter: 5.12 m

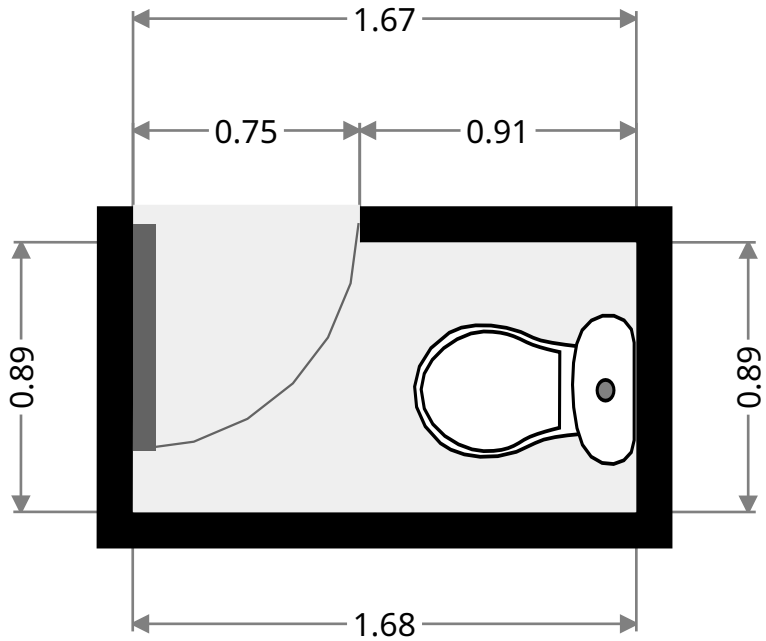
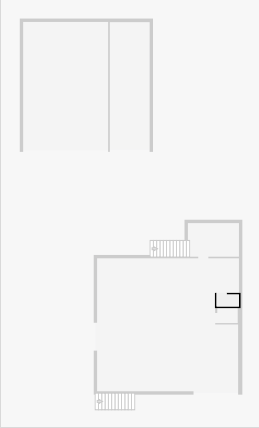

## Bathroom

Width: 1.13 m  
Length: 1.51 m  
Area: 1.72 m<sup>2</sup>  
Perimeter: 5.30 m

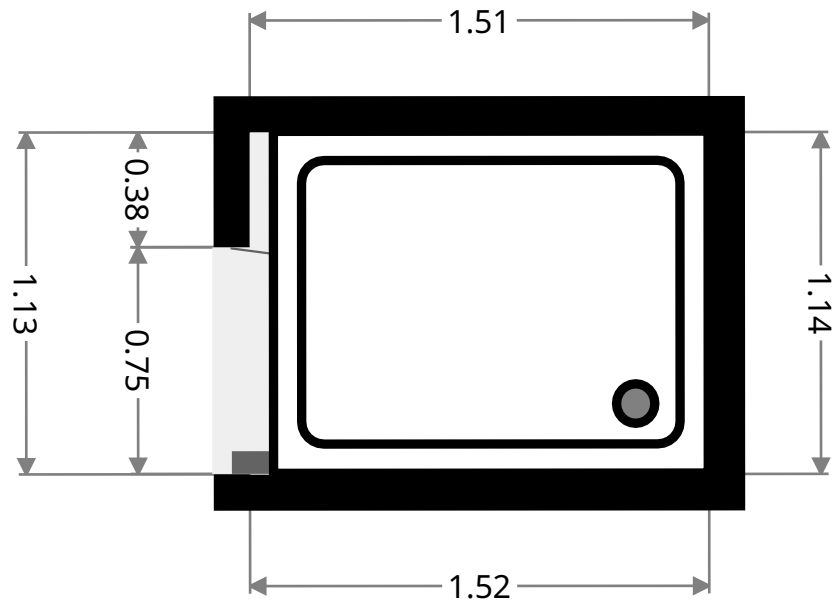
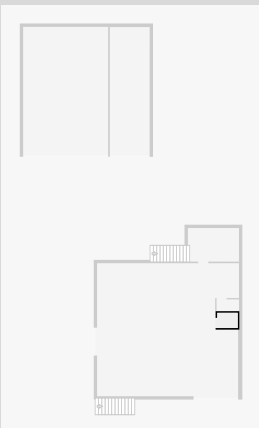

# 191 Vallis Street

## Awning

Width: 2.49 m  
Length: 3.79 m  
Area: 9.46 m<sup>2</sup>  
Perimeter: 12.58 m

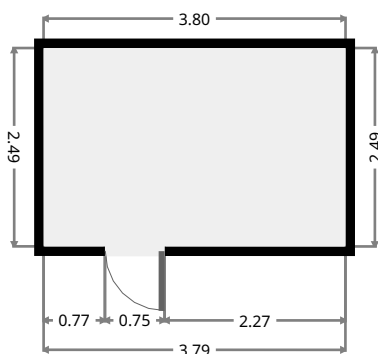
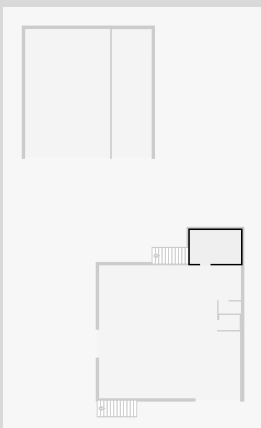

## Carport

Width: 6.32 m  
Length: 9.41 m  
Area: 59.40 m<sup>2</sup>  
Perimeter: 31.44 m

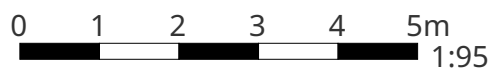
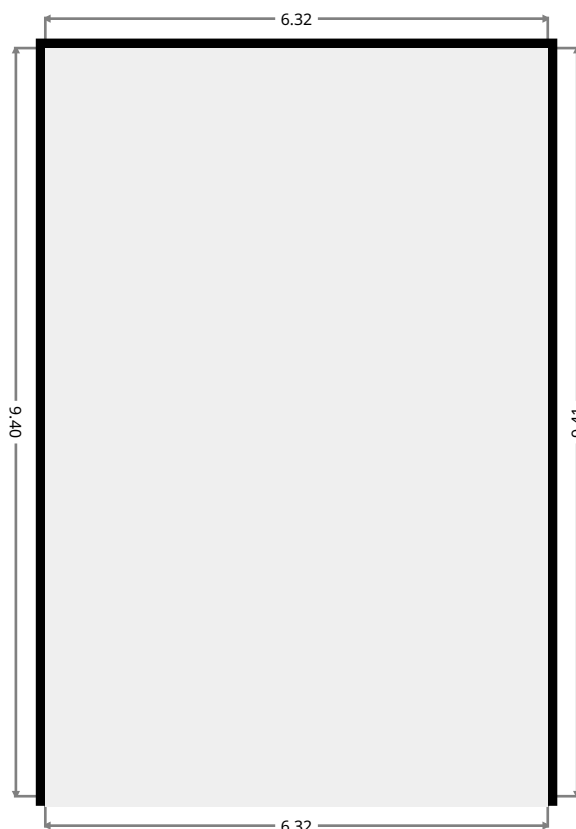
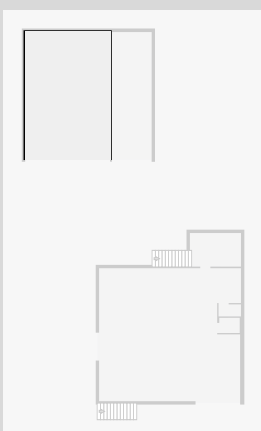

THIS FLOORPLAN IS PROVIDED WITHOUT WARRANTY OF ANY KIND. SENSOPIA DISCLAIMS ANY WARRANTY INCLUDING, WITHOUT LIMITATION, SATISFACTORY QUALITY OR ACCURACY OF DIMENSIONS.

# 191 Vallis Street

## Shed

Width: 2.96 m  
Length: 9.37 m  
Area: 27.75 m<sup>2</sup>  
Perimeter: 24.67 m

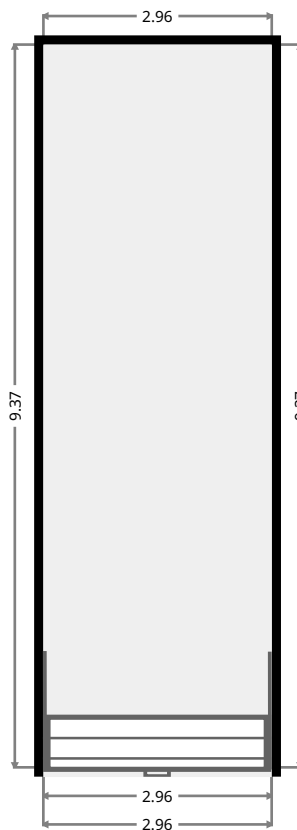
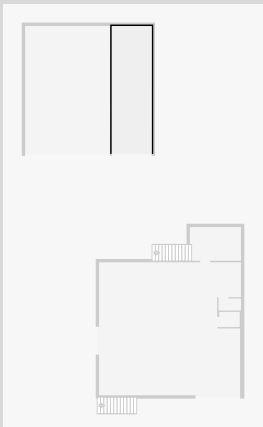

# 191 Vallis Street

## 1st Floor

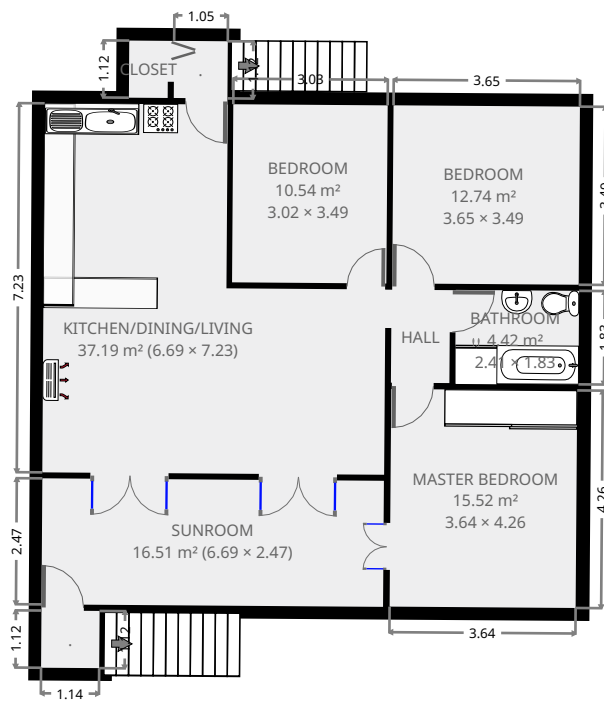

THIS FLOORPLAN IS PROVIDED WITHOUT WARRANTY OF ANY KIND. SENSOPIA DISCLAIMS ANY WARRANTY INCLUDING, WITHOUT LIMITATION, SATISFACTORY QUALITY OR ACCURACY OF DIMENSIONS.



# 191 Vallis Street

## Sunroom

Width: 2.47 m  
 Length: 6.69 m  
 Area: 16.51 m<sup>2</sup>  
 Perimeter: 18.31 m

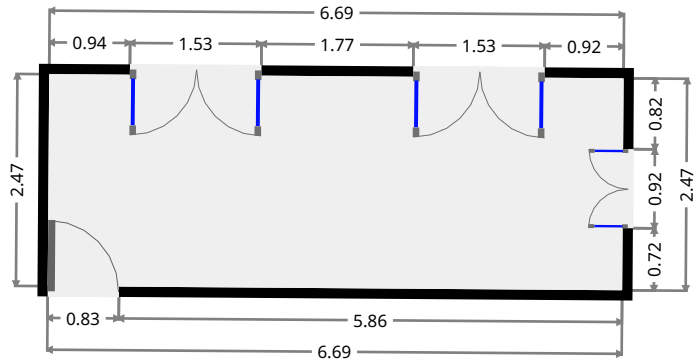
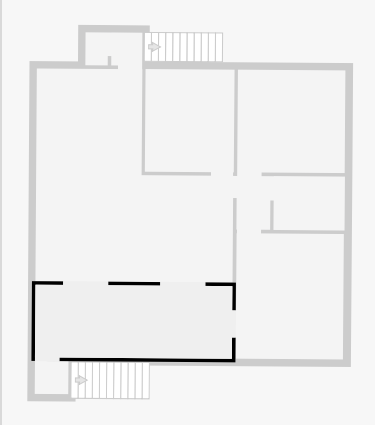

## Kitchen/Dining/Living

Width: 6.69 m  
 Length: 7.23 m  
 Area: 37.19 m<sup>2</sup>  
 Perimeter: 27.85 m

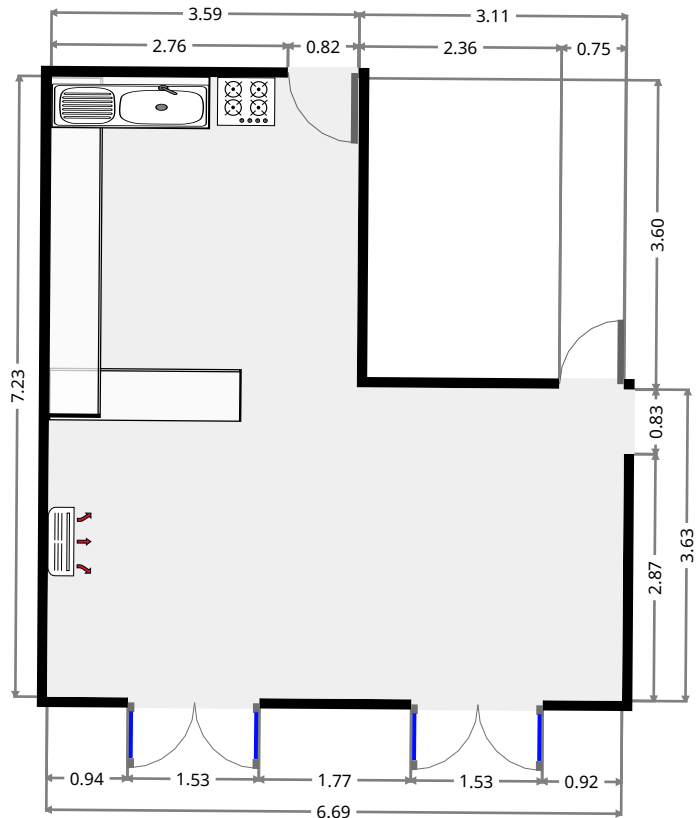
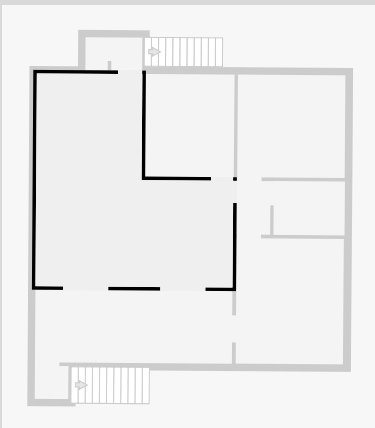

THIS FLOORPLAN IS PROVIDED WITHOUT WARRANTY OF ANY KIND. SENSOPIA DISCLAIMS ANY WARRANTY INCLUDING, WITHOUT LIMITATION, SATISFACTORY QUALITY OR ACCURACY OF DIMENSIONS.

# 191 Vallis Street

## Bedroom

Width: 3.02 m  
Length: 3.49 m  
Area: 10.54 m<sup>2</sup>  
Perimeter: 13.02 m

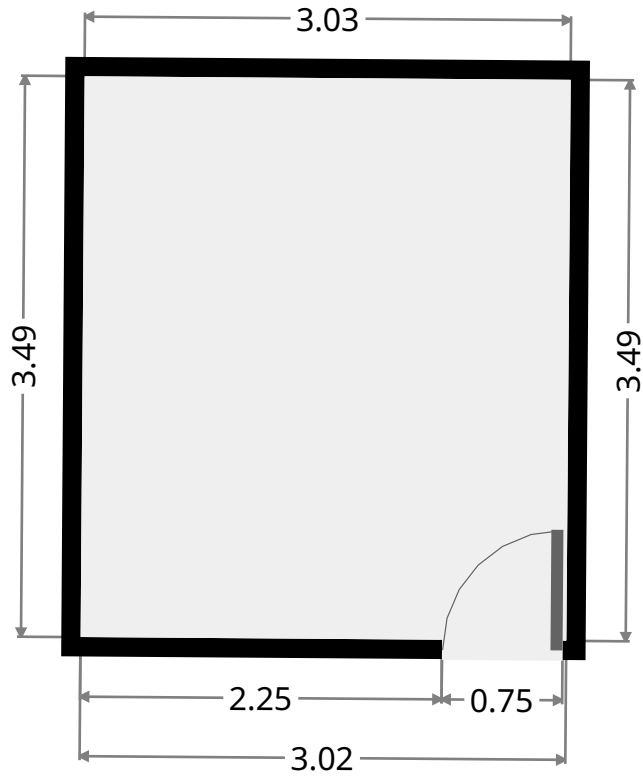
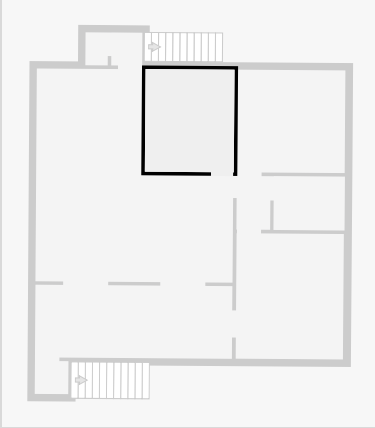

## Hall

Width: 1.15 m  
Length: 1.82 m  
Area: 2.09 m<sup>2</sup>  
Perimeter: 5.93 m

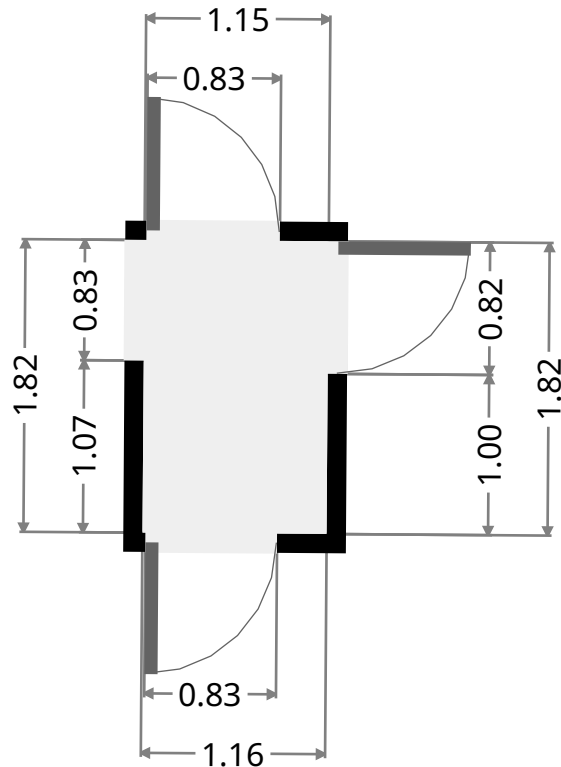
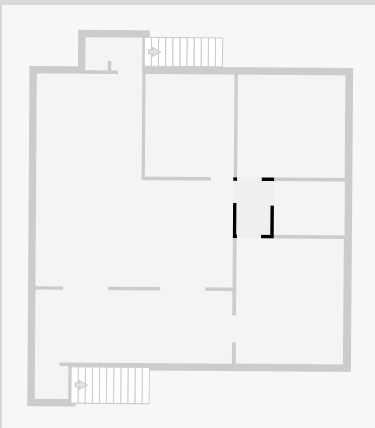



# 191 Vallis Street

## Master Bedroom

Width: 3.64 m  
Length: 4.26 m  
Area: 15.52 m<sup>2</sup>  
Perimeter: 15.81 m

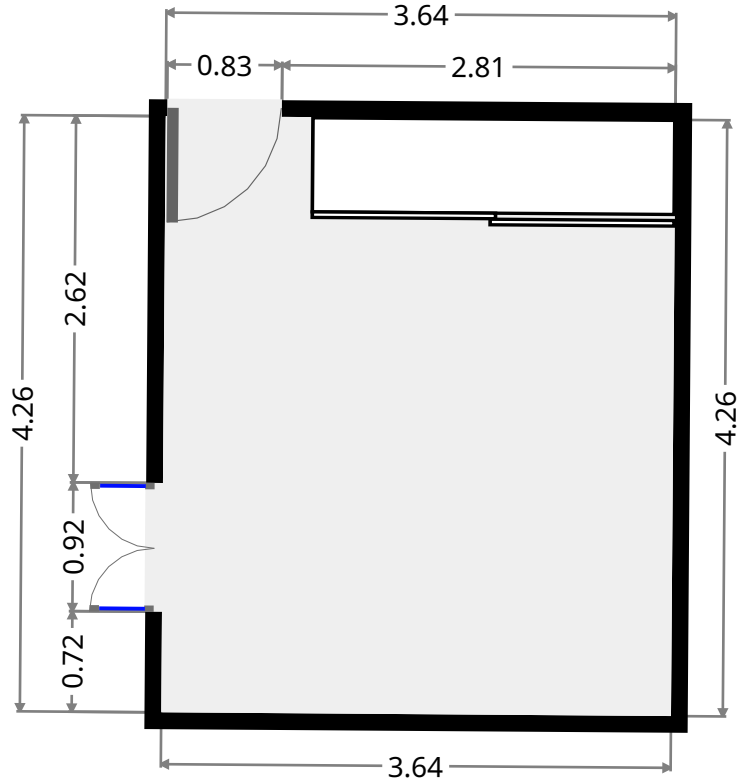
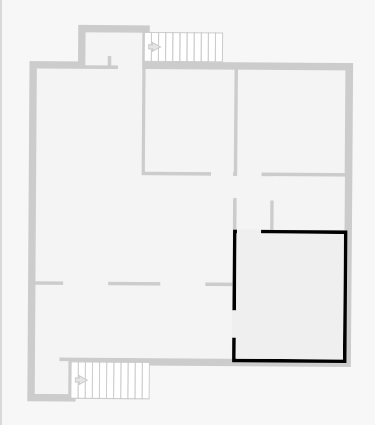

## Bathroom

Width: 1.83 m  
Length: 2.41 m  
Area: 4.42 m<sup>2</sup>  
Perimeter: 8.49 m

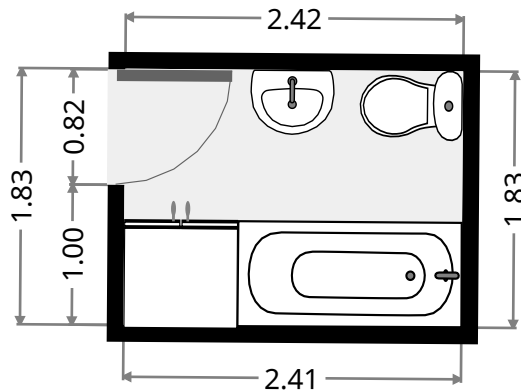
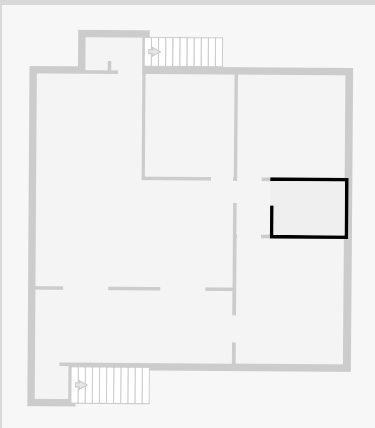

# 191 Vallis Street

## Bedroom

Width: 3.49 m  
 Length: 3.65 m  
 Area: 12.74 m<sup>2</sup>  
 Perimeter: 14.28 m

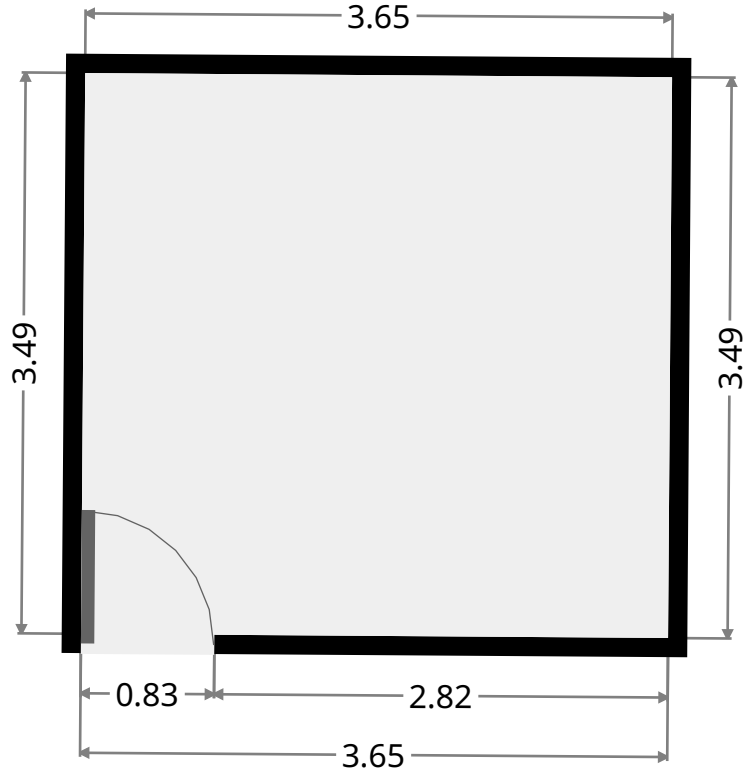
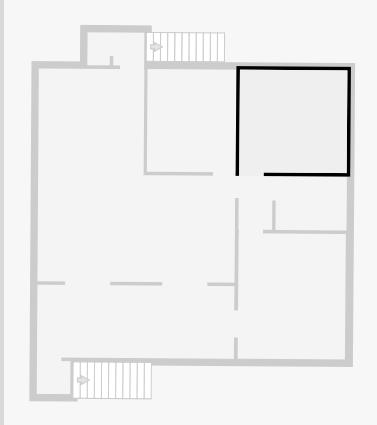

•  
 Width: 1.05 m  
 Length: 1.12 m  
 Area: 1.17 m<sup>2</sup>  
 Perimeter: 4.34 m

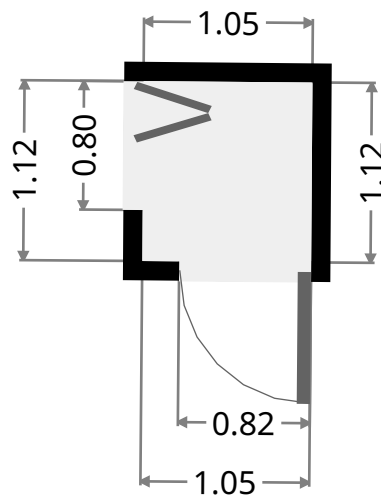
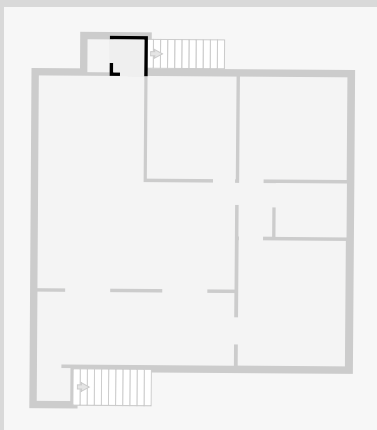

# 191 Vallis Street

## Closet

Width: 0.76 m  
 Length: 1.12 m  
 Area: 0.85 m<sup>2</sup>  
 Perimeter: 3.75 m

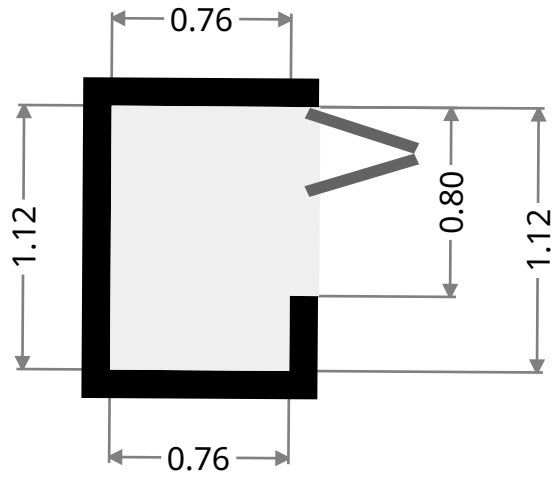
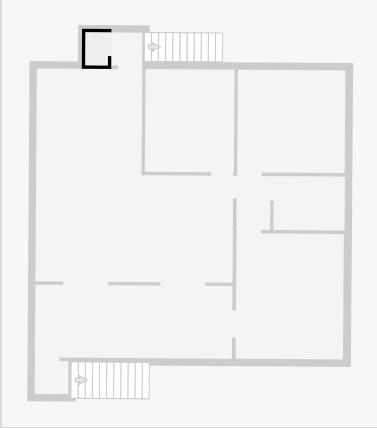

•  
 Width: 1.12 m  
 Length: 1.14 m  
 Area: 1.27 m<sup>2</sup>  
 Perimeter: 4.52 m

